

Machine Controller MP940

USER'S MANUAL

DESIGN AND MAINTENANCE



Safety Information

The following conventions are used to indicate precautions in this manual. Failure to heed precautions provided in this manual can result in serious or possibly even fatal injury or damage to the products or to related equipment and systems.

WARNING

Indicates precautions that, if not heeded, could possibly result in loss of life or serious injury.

Caution

Indicates precautions that, if not heeded, could result in relatively serious or minor injury, damage to the product, or faulty operation.

In some situations, the precautions indicated could have serious consequences if not heeded.

Prohibited

Indicates prohibited actions that must not be performed. For example, this symbol would be used to indicate that fire is prohibited as follows: .

Mandatory

Indicates compulsory actions that must be performed. For example, this symbol would be used as follows to indicate that grounding is compulsory: .

Visual Aids

The following aids are used to indicate certain types of information for easier reference.

IMPORTANT

Indicates important information that should be memorized.

Also, indicates low-level precautions that, if not heeded, may cause an alarm to sound but will not result in the device being damaged.



Indicates additional information or information that is useful to have memorized.



Describes technical terms that are difficult to understand, or appear in the text without an explanation being given.

Copyright © Yaskawa Corporation, 2000.

All rights reserved. No part of this publication may be reproduced, stored in a retrieval system, or transmitted, in any form, or by any means, mechanical, electronic, photocopying, recording, or otherwise, without the prior written permission of Yaskawa. No patent liability is assumed with respect to the use of the information contained herein. Moreover, because Yaskawa is constantly striving to improve its high-quality products, the information contained in this manual is subject to change without notice. Every precaution has been taken in the preparation of this manual. Nevertheless, Yaskawa assumes no responsibility for errors or omissions. Neither is any liability assumed for damages resulting from the use of the information contained in this publication.

CONTENTS

Safety Information	iii
Visual Aids	iv
About this Manual	xiii
Related Manuals	xiii
Using This Manual	xiv
Safety Precautions	xv

1 MP940 Overview and Features

1.1 Appearance of MP940 Modules	1-2
1.2 List of Modules	1-2
1.3 Features of the MP940	1-3
1.3.1 Single-axis Controller with Enhanced Essential Functions	1-3
1.3.2 Total Synchronization between Controller and Servo Amplifier	1-4
1.3.3 Reduced Wiring and Compact Size	1-4
1.3.4 Wide Range of Motion Controls	1-4
1.3.5 High-precision Synchronous Control	1-5
1.3.6 Field Networks	1-6

2 Specifications and Functions

2.1 General Specifications	2-2
2.2 Hardware Specifications	2-3
2.3 Function Lists	2-5
2.3.1 MP940 Motion Control Function Specifications	2-5
2.3.2 PLC Function Specifications	2-6
2.3.3 Motion Command Descriptions	2-8
2.3.4 Ladder Instructions and Standard System Functions	2-13
2.4 Main CP-717 Functions	2-21
2.5 Function Tree Structure	2-22
2.6 SERVOPACK Specifications	2-23
2.6.1 Outer Appearance and Nameplate Example	2-23
2.6.2 Model Numbers	2-23

3 Basic System Operation

3.1 Operating Modes	3-3
3.1.1 Online Operating Mode	3-3
3.1.2 Offline Stop Mode	3-3
3.2 Start and Stop Sequences	3-5
3.2.1 DIP Switch Settings	3-5
3.2.2 Start Sequence	3-7
3.3 Scan Processing	3-10
3.3.1 Overview of Scan Processing	3-10
3.3.2 S Scan Details	3-11
3.3.3 Setting Scan Times	3-12
3.3.4 Setting the System Scan Time	3-13
3.3.5 Setting Scan Time Definitions	3-14
3.3.6 Saving Scan Time Definitions	3-15
3.3.7 Completing Scan Time Definitions	3-15
3.4 User Programs	3-16
3.4.1 Drawings (DWGs)	3-16
3.4.2 Execution Control of Parent Drawings	3-17
3.4.3 Motion Programming	3-20
3.5 Functions	3-28
3.5.1 Standard System Functions	3-28
3.5.2 Creating User Functions	3-29
3.5.3 Determining the I/O Specifications	3-29
3.5.4 Defining Function I/O	3-30
3.5.5 Creating the Body of the Function	3-31
3.5.6 Creating the Program that Calls the Function	3-32
3.6 Registers	3-34
3.6.1 Register Designation Methods	3-34
3.6.2 Data Types	3-35
3.6.3 Types of Register	3-38
3.6.4 Using Subscripts I and J	3-40
3.6.5 I/O and Registers in Functions	3-42
3.6.6 Register Ranges in Programs	3-43
3.7 Managing Symbols	3-44
3.7.1 Symbols in Drawings	3-44
3.7.2 Symbols in Functions	3-44
3.7.3 Upward Linking of Symbols	3-45
3.7.4 Automatic Register Number Allocation	3-45

4 MP940 Functions

4.1 MP940 Function Configuration	4-3
4.1.1 Overview	4-3
4.1.2 Simulated MP940 Building Block Configuration	4-5
4.2 Serial Communications Function	4-6
4.2.1 Overview	4-6
4.2.2 System Configuration	4-6
4.2.3 Communications Specifications	4-7
4.2.4 Connectors	4-8
4.2.5 Time Required for Transmission	4-9
4.2.6 Serial Communications Protocol	4-11
4.2.7 Opening the Serial Definition Window	4-17
4.2.8 General-purpose Serial Definitions	4-18
4.2.9 Saving General-purpose Serial Definition Data	4-21
4.2.10 Deleting General-purpose Serial Definition Data	4-21
4.3 LIO Function	4-22
4.3.1 Overview	4-22
4.3.2 LIO Specifications	4-23
4.3.3 Opening the Local I/O Definition Window	4-26
4.3.4 LIO Definitions	4-27
4.3.5 Saving LIO Definition Data	4-28
4.3.6 Deleting LIO Definition Data	4-28
4.4 CNTR Function	4-29
4.4.1 Overview	4-29
4.4.2 Counter Specifications	4-30
4.4.3 Counter Function Configuration	4-31
4.4.4 Pulse Count Method	4-32
4.4.5 Reversible Counter Mode	4-34
4.4.6 Coincidence Output and Interrupt Functions	4-34
4.4.7 PI Latch Function	4-36
4.4.8 Electronic Gear	4-36
4.4.9 Opening the Counter Module Definition Window	4-40
4.4.10 Defining Counter I/O	4-41
4.4.11 Setting I/O Data	4-42
4.4.12 Saving Counter I/O Definition Data	4-44
4.4.13 Deleting Counter I/O Definition Data	4-44
4.5 MECHATROLINK Functions	4-45
4.5.1 MECHATROLINK Overview	4-45
4.5.2 MECHATROLINK Communications Specifications	4-45
4.5.3 Master and Slaves	4-46
4.5.4 MECHATROLINK Connections	4-51
4.5.5 Opening the MECHATROLINK Window	4-52

4.5.6 Setting MECHATROLINK Definitions	4-53
4.5.7 Saving MECHATROLINK Definitions	4-56
4.5.8 Deleting MECHATROLINK Definitions	4-56
4.5.9 Ending MECHATROLINK Definitions	4-56
4.6 DeviceNet Functions	4-57
4.6.1 System Configuration	4-57
4.6.2 I/O Communications Function	4-58
4.6.3 Communications Specifications	4-58
4.6.4 260IF Module Setup	4-59
4.7 SVA Function	4-65
4.7.1 Overview	4-65
4.7.2 Separate and One-unit Systems	4-65
4.7.3 MP940 Servo Control Function	4-66
4.7.4 Setting Parameters of the SGDH SERVOPACK	4-70
4.8 Flash Memory Operation	4-77
4.8.1 Overview	4-77
4.8.2 Saving to Flash	4-77
4.8.3 Starting Flash Memory	4-79

5 System Startup

5.1 Handling the SERVOPACK	5-3
5.2 Part Names	5-4
5.2.1 MP940 Module	5-4
5.2.2 Accessories and Options	5-15
5.3 Connection Methods	5-16
5.3.1 Connectors	5-16
5.3.2 Connector Specifications	5-17
5.3.3 Serial Port Connector Pin Arrangements and I/O Circuits	5-18
5.3.4 I/O Connector Pin Arrangement and I/O Circuits	5-23
5.3.5 Power Supply Connector Cable	5-25
5.3.6 MECHATROLINK Cable	5-26
5.4 Connecting Peripheral Devices	5-28
5.4.1 Single Phase Power Supply Specifications	5-28
5.4.2 Three-phase Power Supply Specifications	5-29
5.4.3 Standard Cable Table	5-30
5.5 SERVOPACK Main Circuit Connection	5-33
5.5.1 Names and Descriptions of Main Circuit Terminals	5-33
5.5.2 Typical Main Circuit Wiring	5-34
5.5.3 Wiring Main Circuit Terminal Blocks	5-35

5.6 SERVOPACK I/O Signals- - - - -	5-37
5.6.1 Examples of I/O Signal Connections - - - - -	5-37
5.6.2 List of CN1 Terminals- - - - -	5-38
5.6.3 I/O Signal Names and Functions- - - - -	5-39
5.6.4 Interface Circuits - - - - -	5-41
5.7 Wiring Encoders - - - - -	5-43
5.7.1 Connecting an Encoder (CN2) and Output Signals from the SERVOPACK (CN1)- - - - -	5-43
5.7.2 CN2 Encoder Connector Terminal Layout and Types - - - - -	5-44
5.8 System Startup - - - - -	5-46
5.8.1 Overview of the Startup Procedure - - - - -	5-46
5.8.2 Test System Configuration - - - - -	5-47
5.8.3 Test System Outline- - - - -	5-48
5.8.4 Equipment Preparations- - - - -	5-49
5.8.5 Mounting the MP940 Module - - - - -	5-50
5.8.6 Mounting the Battery Holder - - - - -	5-52
5.8.7 Connections and Wiring - - - - -	5-54
5.8.8 MP940 Initialization - - - - -	5-55
5.8.9 Starting the CP-717 - - - - -	5-57
6 Parameters	
6.1 Parameter Classifications- - - - -	6-2
6.2 Motion Setting Parameters- - - - -	6-3
6.2.1 Opening the Motion Parameters Window- - - - -	6-3
6.2.2 Setting Motion Parameters - - - - -	6-4
6.2.3 Deleting Motion Parameters - - - - -	6-7
6.2.4 Saving Motion Parameters - - - - -	6-8
6.3 SVA Parameter Details - - - - -	6-9
6.3.1 Motion Fixed Parameter Details - - - - -	6-9
6.3.2 Motion Setting Parameter Details - - - - -	6-17
6.3.3 Motion Monitoring Parameter Details- - - - -	6-37
6.4 Parameters for SGDH SERVOPACK- - - - -	6-46
6.4.1 Parameter Configurations- - - - -	6-46
6.4.2 Function Selection Constants - - - - -	6-46
6.4.3 Gain-related Parameters - - - - -	6-53
6.4.4 Position-related Parameters - - - - -	6-59
6.4.5 Speed-related Parameters - - - - -	6-60
6.4.6 Torque-related Parameters- - - - -	6-62
6.4.7 Sequence-related Parameters - - - - -	6-66
6.4.8 Other Parameters - - - - -	6-74

7 Absolute Position Detection

7.1 Structure of the Absolute Position Detection Function- - - - -	7-2
7.1.1 Description of the Function - - - - -	7-2
7.1.2 Structure of Absolute Position Detection - - - - -	7-2
7.2 Starting the Absolute Position Detection Function- - - - -	7-6
7.2.1 System Startup Procedure- - - - -	7-6
7.2.2 Setting Related Parameters- - - - -	7-7
7.2.3 Initializing the Absolute Encoder- - - - -	7-8
7.2.4 Multi-turn Limit Setting- - - - -	7-11
7.3 Using an Absolute Encoder - - - - -	7-14
7.3.1 Finite Length Mode Axis - - - - -	7-14
7.3.2 Infinite Length Mode Axis - - - - -	7-18

8 Maintenance and Inspection

8.1 Inspection Items - - - - -	8-2
8.1.1 Daily Inspections - - - - -	8-2
8.1.2 Regular Inspections - - - - -	8-3
8.2 MP940 Module Battery - - - - -	8-4
8.2.1 Battery Life- - - - -	8-4
8.2.2 Battery Replacement- - - - -	8-4

9 Troubleshooting

9.1 Overview of Troubleshooting - - - - -	9-2
9.1.1 Troubleshooting Methods - - - - -	9-2
9.1.2 Basic Troubleshooting Flow - - - - -	9-3
9.1.3 Indicator Errors- - - - -	9-3
9.2 System Errors- - - - -	9-5
9.2.1 Overview of System Errors - - - - -	9-5
9.2.2 Processing Flow When a System Error Occurs - - - - -	9-6
9.2.3 Processing Flow When a User Program Error Occurs - - - - -	9-7
9.2.4 System Register Configuration- - - - -	9-8
9.3 Motion Errors - - - - -	9-19
9.3.1 Description of Motion Errors- - - - -	9-19
9.3.2 Processing Flow When a Motion Error Occurs- - - - -	9-20

10	SERVOPACK Inspection, Maintenance, and Troubleshooting	
10.1	Servodrive Inspection and Maintenance	10-2
10.1.1	Servomotor Inspection	10-2
10.1.2	SERVOPACK Inspection	10-2
10.1.3	Replacing Battery for Absolute Encoder	10-3
10.2	Troubleshooting	10-5
10.2.1	Troubleshooting Problems with Alarm Displays	10-5
10.2.2	Troubleshooting Problems with No Alarm Display	10-31
10.2.3	Alarm Display Table	10-33
11	Motion Control	
11.1	Overview of Motion Control	11-2
11.1.1	Motion Control for the MP940	11-2
11.1.2	Motion Control Methods	11-2
11.1.3	Examples of Motion Control Applications	11-5
11.2	Control Modes	11-7
11.2.1	Overview of Control Modes	11-7
11.2.2	Speed Control Mode	11-7
11.2.3	Torque Control Mode	11-12
11.2.4	Phase Control Mode	11-15
11.2.5	Zero Point Return Mode	11-23
11.3	Position Control	11-28
11.3.1	Prerequisites for Position Control	11-28
11.3.2	Precautions in Changing to Position Control Mode	11-43
11.3.3	Position Control without Using Motion Commands	11-47
11.4	Position Control Using Motion Commands	11-50
11.4.1	Overview of Motion Commands	11-50
11.4.2	Positioning (POSING)	11-52
11.4.3	External Positioning (EX_POSING)	11-58
11.4.4	Zero Point Return (ZRET)	11-61
11.4.5	Interpolation (INTERPOLATE)	11-73
11.4.6	Interpolation with Position Detection (LATCH)	11-74
11.4.7	Fixed Speed Feed (FEED)	11-75
11.4.8	Fixed Length Feed (STEP)	11-78
11.4.9	Zero Point Setting (ZSET)	11-81

A Dimensions	A-1
A.1 External of MP940 Module	A-2
A.2 Dimensions of MP940D	A-2
B Lists of Parameters	B-1
B.1 Classification of Parameters	B-2
B.2 Parameters	B-2
B.3 Switches	B-6
B.4 Input Signal Selections	B-10
B.5 Output Signal Selections	B-11
B.6 Auxiliary Functions	B-12
B.7 Monitor Modes	B-13
C Motion Parameter Tables	C-1
C.1 Motion Fixed Parameters	C-2
C.2 Motion Setting Parameters	C-5
C.3 Motion Monitoring Parameters	C-12
D Lists of System Registers	D-1
D.1 System (S) Register Allocations	D-2
D.2 System Service Registers	D-2
D.3 Scan Execution Status and Calendar	D-5
D.4 System Program Software Number and Available Program Memory	D-5

Revision History

About this Manual

- This manual describes the design and maintenance for the MP940 Machine Controller, including the following information.
 - Overview and component specifications
 - Installation and wiring
 - Examples of internal panel layout and drilling plan
- Read this manual carefully to ensure the proper use of the MP940 Machine Controller. Also, keep this manual in a safe place so that it can be referred to whenever necessary.

Related Manuals

- Refer to the following related manuals as required.
- Thoroughly check the specifications, restrictions, and other conditions of the product before attempting to use it.

Manual Name	Manual No.	Contents
MP9□□ Machine Controller User's Manual: Ladder Programming	SIEZ-C887-1.2	Describes the processing instructions used in MP9□□ ladder programs.
MP9□□ Machine Controller User's Manual: Motion Programming	SIEZ-C887-1.3	Describes the motion programming language used for the MP9□□.
MP9□□ Machine Controller User's Manual: Programming Panel Software (for simple operation/standard operation)	SIEZ-C887-2.3 (for simple operation) (To be prepared), SIEZ-C887-2.4 (for standard operation) (To be prepared)	Describes the CP-717 Programming Panel Software used for designing and maintaining the MP9□□.
Σ - II Series SGM□ H/SGDH User's Manual: Design and Maintenance	SIE-S800-32.2	Describes SGM□ H/SGDH functions, specifications, and operating procedures.

Using This Manual

■ Intended Audience

This manual is intended for the following users.

- Those responsible for estimating the MP940 system
- Those responsible for deciding whether to apply the MP940 system
- Those responsible for designing the MP940 system so that it can be mounted in the control and operating panels
- Those responsible for making, inspecting, testing, adjusting, and maintaining the control and operating panels in which the MP940 is mounted

■ Description of Technical Terms

In this manual, the following terms are defined as follows:

- MP940 = MP940 Machine Controller, which consists of a Power Supply Module, CPU Module, I/O Modules, and other Modules
- PP = Programming Panel
- PC = Programmable Logic Controller
- “--” in “MOV [axis1]--...” represents numeric data for axis 1.

■ Inverted Signals

In this manual, a slash (/) is placed in front of the name of any signal that is valid when low (L).

- $\overline{S-ON}$ = /S-ON
- $\overline{P-CON}$ = /P-CON

Safety Precautions

This section describes precautions that apply to correct use of devices. Before installing, operating, maintaining or inspecting devices, always read this manual and all other documents provided to ensure correct programming. Before using the equipment, familiarize yourself with equipment details, safety information, and all other precautions.

■ Installation

Caution

- Always mount the Module securely using the Module mounting spring.

A loose spring may result in a malfunction of the MP940.

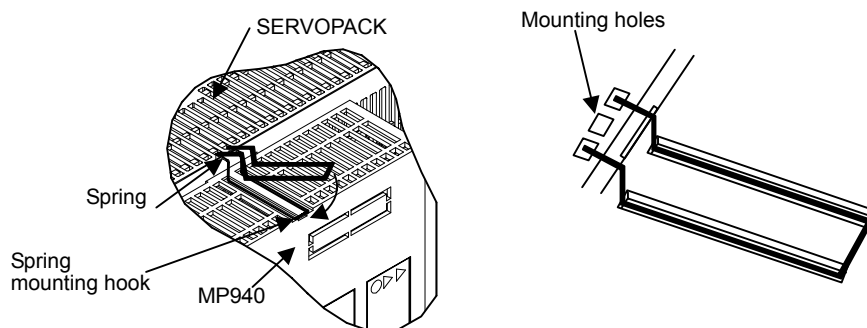

- Always turn OFF the MP940 Module before installing or removing it.
- Insert the connectors of the cables to be connected to the Module and secure them well.

Incorrect insertion of the connectors may result in a malfunction of the MP940.

■ Wiring

Caution

- Always connect a power supply that meets the specifications.
Connecting an inappropriate power supply may cause fires.
- Wiring must be performed by qualified personnel.
Incorrect wiring may cause fires, product failure, or malfunctions.
- Do not accidentally leave foreign matter such as wire chips in the Module when wiring.
This may cause fires, failures, and malfunctions.

Mandatory

- Always ground the FG terminal to a ground resistance 100 Ω or less.
Failure to ground the MP940 may result in electrical shocks or malfunctions.

Select, separate, and lay external cables correctly.

- Consider the following items when selecting the I/O signal lines (external cables) to connect the MP940 to external devices.
 - Mechanical strength
 - Noise interference
 - Wiring distance
 - Signal voltage, etc.
- Separate the I/O signal lines from the power lines both inside and outside the control panel to reduce the influence of noise from the power lines.

If the I/O signal lines and power lines are not separated properly, malfunctioning may result.

Example of Separated External Cables

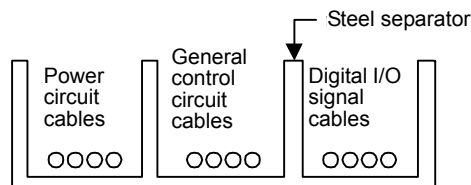

■ Application

WARNING

- Do not touch any Module terminals when the system power is ON.
There is a risk of electrical shock.

Caution

- Do not attempt to modify the MP940 programs, force outputs, switch between RUN and STOP, or performed other similar operations while the MP940 is operating.
Incorrect programming or operation may damage the equipment or cause an accident.

■ Maintenance

WARNING

- Make sure that the polarity of the Module's built-in battery is correct. The battery must be installed correctly and must not be charged, disassembled, heated, thrown into fire, or short-circuited.
Improper handling may cause the battery to explode or ignite.

Prohibited

- Do not attempt to disassemble or modify the MP940 in any way.
Doing so can cause fires, product failure, or malfunctions.
- The customer must not replace any built-in fuses.
If the customer replaces a built-in fuse, the MP940 may malfunction or break down. The built-in fuse must always be replaced by Yaskawa service staff.

■ General Precautions

Always note the following to ensure safe use.

- The MP940 was not designed or manufactured for use in devices or systems directly related to human life. Users who intend to use the product described in this manual for special purposes such as devices or systems relating to transportation, medical, space aviation, atomic power control, or underwater use must contact Yaskawa Electric Corporation beforehand.
- The MP940 has been manufactured under strict quality control guidelines. However, if this product is to be installed in any location in which a failure of the MP940 involves a life and death situation or in a facility where failure may cause a serious accident, safety devices **MUST** be installed to minimize the likelihood of any accident.
- Drawings in this manual show typical product examples that may differ somewhat from the product delivered.
- This manual may change without prior notice due to product improvements and specification changes or for easier use. We will update the manual number of the manual and issue revisions when changes are made. The revision number of the revised manual appears on the back of the manual.
- Contact your nearest Yaskawa sales representative or the dealer from whom you purchased the product and quote the manual number on the front page of the manual if you need to replace a manual that was lost or destroyed.
- Contact your nearest Yaskawa sales representative or the dealer from whom you purchased the product to order new nameplates whenever a nameplate becomes worn or damaged.
- Products modified by the customer are not covered by the Yaskawa warranty, nor does Yaskawa assume any liability for injury or damage that may result from such modifications.

1 MP940 Overview and Features

This chapter provides an overview and outlines the features of the MP940 Modules.

1.1 Appearance of MP940 Modules-	1-2
1.2 List of Modules	1-2
1.3 Features of the MP940	1-3
1.3.1 Single-axis Controller with Enhanced Essential Functions	1-3
1.3.2 Total Synchronization between Controller and Servo Amplifier	1-4
1.3.3 Reduced Wiring and Compact Size	1-4
1.3.4 Wide Range of Motion Controls	1-4
1.3.5 High-precision Synchronous Control-	1-5
1.3.6 Field Networks	1-6

1.1 Appearance of MP940 Modules

The MP940 is a single-axis controller with functions such as communications, local I/O, counters, motion control, and so on, and with a bus connection to an SGDh SERVOPACK.

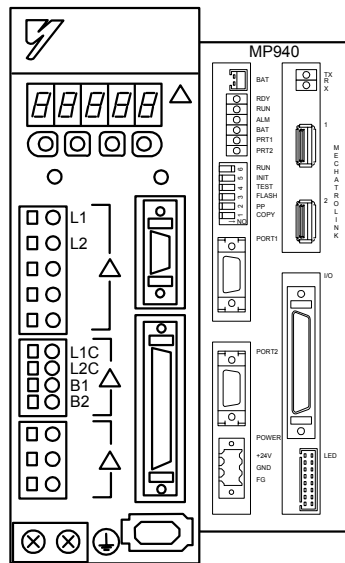

MP940 (JEPMC-MC400)

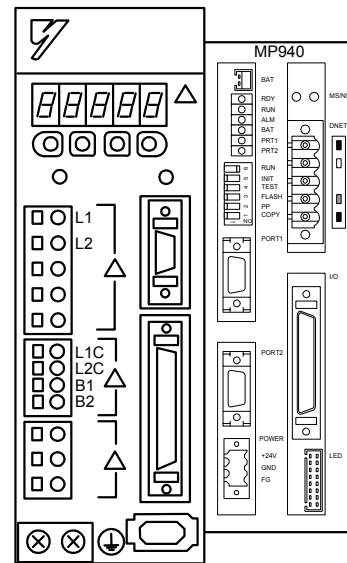

MP940D (JEPMC-MC410)

1.2 List of Modules

The following table lists the Modules and devices used for the MP940 system.

Table 1.1 List of Modules

Group	Name	Description
MP940 Module for MECHATROLINK	JEPMC-MC400	MP940
MP940 Module for DeviceNet	JEPMC-MC410	MP940D

1.3 Features of the MP940

The MP940 Machine Controller is a single-axis controller which combines controller and SERVOPACK features into a single unit. It provides a wide range of control features, from independent positioning to fast and accurate synchronous control.

1.3.1 Single-axis Controller with Enhanced Essential Functions

The MP940 is configured from the functional modules shown in the following table, based on servo control.

Functional Module	Contents
MP940	CPU
SERIAL	Serial communications, RS-232C, RS-422/485
LIO	Local I/O: DI (8 bits), DO (8 bits), AO (1 word)
SVA	Motion control functions
CNTR	Counter functions
MLINK or DevNet	MECHATROLINK interface or DeviceNet interface

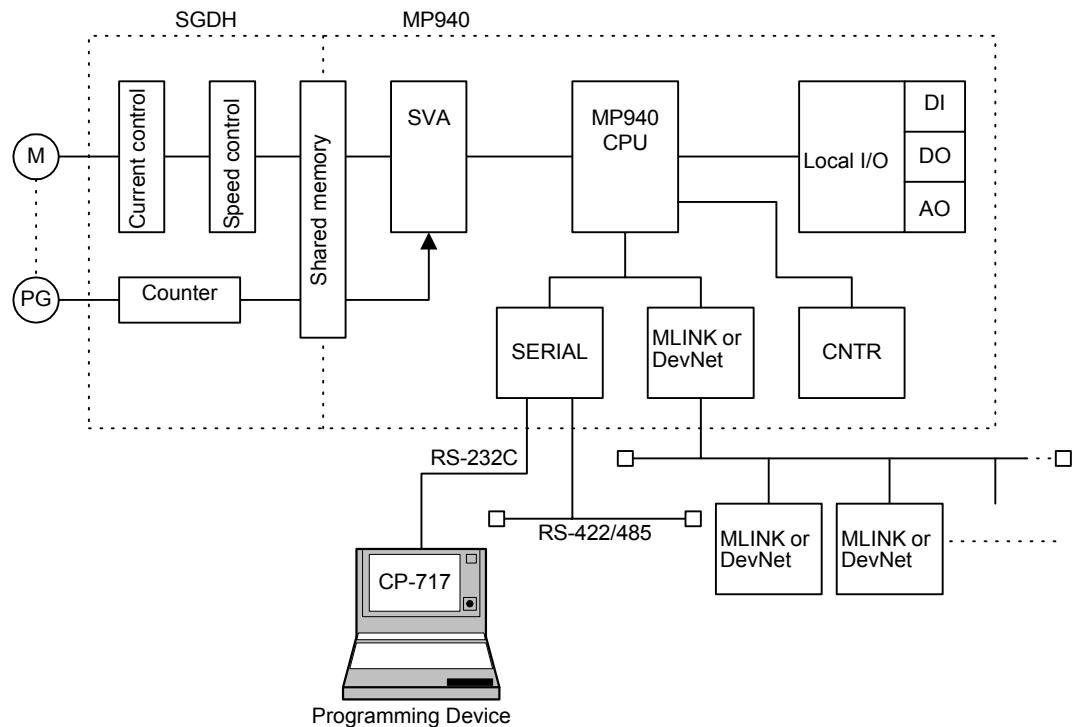

1.3.2 Total Synchronization between Controller and Servo Amplifier

The Controller and SGD_H SERVOPACK have a bus connection for totally synchronized execution that enables fast and accurate control with no startup or monitoring delays.

Any of the following control cycles can be set.

- 500 μ s, 1 ms, 2 ms, 4 ms,

1.3.3 Reduced Wiring and Compact Size

Combining the Controller and SERVOPACK into a single unit has reduced wiring costs and achieved space saving.

1.3.4 Wide Range of Motion Controls

- Motion program instructions are executed to perform positioning and linear interpolation.
- High-speed position control, synchronous phase control, speed control, and torque control can be performed.
- Highly effective motion control is possible for electronic shafts and gears.

Servo Control Examples

Position, synchronous phase, speed, and torque control are possible with 4-mode control.

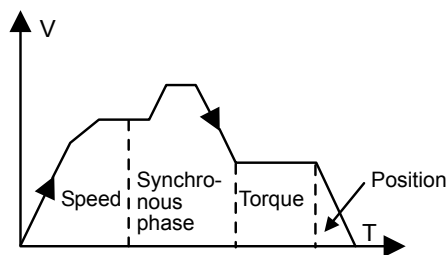
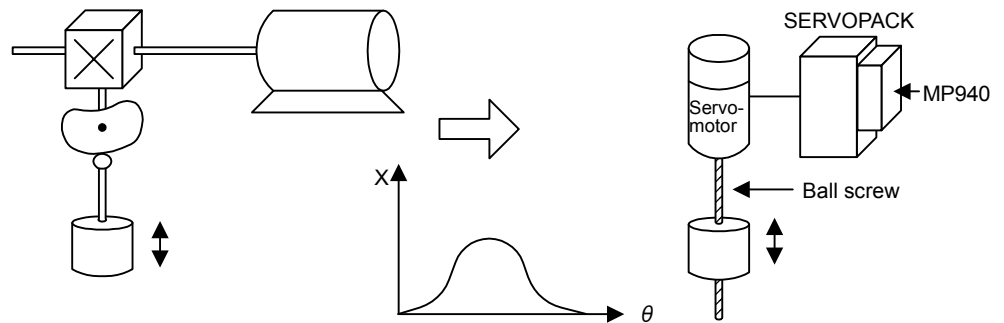

Fig 1.1 4-Mode Control

Synchronous Phase Control Application Examples

◀EXAMPLE▶

Electronic Cams



1.3.5 High-precision Synchronous Control

Various types of position data can be monitored and SERVOPACK parameters can be changed at high speed during machine operation. This data can be used for high-precision synchronous control by executing READ and WRITE in ladder logic programs or motion programs.

- Mode Changes during Operation

The mode can be changed to position control, torque control, speed control, or synchronous phase control during operation.

- Various Operation Commands

Speed loop P/PI switching, external torque control, and speed limits for torque control can be specified from the MP940 during operation.

- Read/Write SERVOPACK Parameters

User-set SERVOPACK parameters, such as position loop gain, speed loop gain, speed loop integral time constant, and so on, can be changed during operation.

- Position Data Monitoring

Position data, command speeds, speed monitoring, and external encoder data can be referenced at high speed by the program.

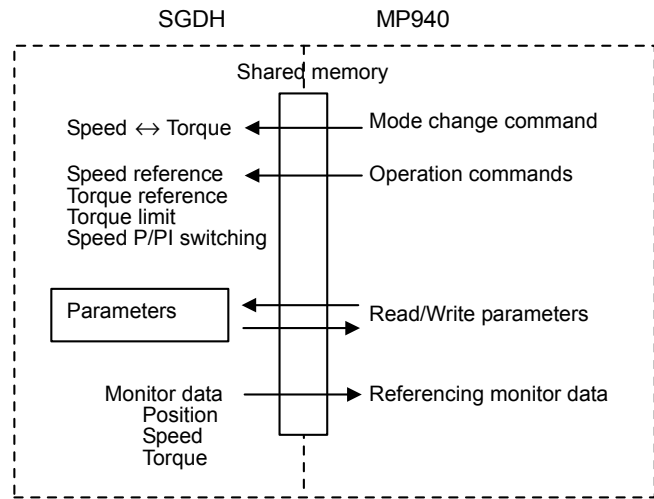

1.3.6 Field Networks

Two types of field network are supported to reduce wiring: One for MECHATROLINK (JEPMC-MC400) and one for DeviceNet (JEPMC-MC410).

2 Specifications and Functions

This chapter outlines MP940 Module specifications and functions.

- 2.1 General Specifications -----2-2
- 2.2 Hardware Specifications -----2-3
- 2.3 Function Lists -----2-5
 - 2.3.1 MP940 Motion Control Function Specifications ----- 2-5
 - 2.3.2 PLC Function Specifications ----- 2-6
 - 2.3.3 Motion Command Descriptions ----- 2-8
 - 2.3.4 Ladder Instructions and Standard System Functions ----- 2-13
- 2.4 Main CP-717 Functions -----2-21
- 2.5 Function Tree Structure -----2-22
- 2.6 SERVOPACK Specifications -----2-23
 - 2.6.1 Outer Appearance and Nameplate Example ----- 2-23
 - 2.6.2 Model Numbers ----- 2-23

2.1 General Specifications

The following table lists the general specifications of the MP940 Modules.

Table 2.1 General Specifications of the MP940 Modules

Item		Specifications
Environmental Conditions	Ambient Operating Temperature	0 to 55°C
	Storage Temperature	-20 to 85°C
	Ambient Operating Humidity	30% to 95% (with no condensation)
	Ambient Storage Humidity	5% to 95% (with no condensation)
	Pollution Level	Pollution level 1 (conforming to JIS B 3501)
	Corrosive Gas	There must be no combustible or corrosive gas.
	Operating Altitude	2,000 m above sea level or lower
Electrical Operating Conditions	Noise Resistance	Conforming to JIS B 3502: 1,500 V (p-p) in either normal or common modes with a pulse width of 100 ns/1 μ s and a rise time of 1 ns (tested with impulse noise simulator)
Mechanical Operating Conditions	Vibration Resistance	Conforming to JIS B 3502: 10 to 57 Hz with single-amplitude of 0.075 mm 57 to 150 Hz with fixed acceleration of 9.8 m/s ² 10 sweeps each in X, Y, and Z directions (sweep time: 1 octave/min)
	Shock Resistance	Conforming to JIS B 3502: Peak acceleration of 147 m/s ² twice for 11 ms each in the X, Y, and Z directions
Installation Requirements	Ground Cooling Method	Ground to 100 Ω max. Natural cooling

2.2 Hardware Specifications

The following table shows the hardware specifications of the MP940 Module.

Table 2.2 Hardware Specifications of the MP940 Module

Item		Specifications	
Name		MP940 (for MECHATROLINK)	MP940D (for DeviceNet)
Model Number		JEPMC-MC400	JEPMC-MC410
Communications Port (Serial Communica- tions)	RS-232C (1 Port)	Baud rate setting: 9.6/19.2 Kbps MDR-14 (special pin assignment) Protocol: <ul style="list-style-type: none"> • MEMOBUS • No-protocol • MELSEC communications 	
	RS-422/485 (1 Port)	Baud rate setting: 9.6/19.2 Kbps MDR-14 (special pin assignment) Protocol: <ul style="list-style-type: none"> • MEMOBUS • No-protocol • MELSEC communications 	
Network		Transmission speed: 4 Mbps Communications cycle: 1 ms, 2 ms, 4 ms Connected nodes: 14 max. (When communications cycle is set to 2 ms)	Transmission speed: 125 kbps, 250 kbps, 500 kbps Mode: Slave Number of nodes: 63 max.
Indicators	Module Status LED Indicators	READY (green)/RUN (green)/ALM (red)/BAT (red)/PRT1 (green)/PRT2 (green)	
	Operation LED Indicators	RX (green) TX (green)	MS (red/green) NS (red/green)
Setting Switches	Mode Setting DIP Switches	RUN/INIT/TEST/FLASH/PP/COPY	
	Piano Switch (MODE) for DeviceNet Communications Settings		PRO, DE1: Baud rate setting X1: Slave/Master selection X2: Not used.
	Rotary Switches (NA) for DeviceNet MAC ID Setting		X1, X10: Node MAC ID (0 to 63)

Item	Specifications	
Input Signals	Inputs	8 points/common
	Input Format	Combined sinking/sourcing
	Input Type	Type 1 (JIS-B3501)
	Isolation Method	Photocoupler isolation
	Working Voltage	17.4 to 28.8 VDC 35 VDC (peak)
	Rated Current	5.3 mA
	Input Impedance	Approx. 4.4 k Ω
	Operating Voltage	ON voltage: 15 VDC or more OFF voltage: 5 VDC or less
	OFF Current	0.9 mA max.
	Response Times	OFF to ON: 0.5 ms or less ON to OFF: 1.5 ms or less
Output Signals	Outputs	8 points/common
	Output Format	Sink output
	Output Type	Transistor output
	Isolation Method	Photocoupler isolation
	Load Voltage	19.2 to 28.8 VDC 35 VDC (peak)
	Load Current	0.1 A/circuit, 0.8 A/common
	ON Voltage	1.0 V max.
	External Power Supply	24 VDC \pm 20% 15 mA
	Output Protection	1 fuse per common
	Fuse Rating	1.5 A (fusing time: Within 5 seconds at 3A)
	Response Times	OFF to ON: 0.25 ms or less ON to OFF: 1 ms or less
Pulse Inputs	Pulse Input Circuit	5 V differential, maximum 1 MHz input
	Pulse Input Method	A/B phase input (selected from 1x, 2x, and 4x), A/B mode, sign mode, up-down mode
	Pulse Counter Latch	(External signal can be switched to 5 V, 12 V, or 24 V.)
Analog Input	SGDH-□□E SERVOPACK	
Analog Outputs	Resolution	16 bits
	Output Range	0 to \pm 10 V
Power Supply Input	Input Signal	24 VDC \pm 20% (19.2 to 28.8 VDC)
	Input Current	0.4 A
	Fuse Rating	1.5 A
	Safety Standards	Conforms to UL and CSA.
Dimensions	44 x 142 x 128 mm (W x H x D)	

2.3 Function Lists

2.3.1 MP940 Motion Control Function Specifications

The following table lists the motion control function specifications for the MP940.

Table 2.3 MP940 Motion Control Function Specifications

Item		Specification
Number of Controlled Axes		1 axis
Control Specifications	PTP Control	Linear, rotary, and infinite-length
	Interpolation	Linear
	Speed Reference Output	Yes
	Torque Reference Output	Yes
	Position Control	Positioning, external positioning, zero point return, interpolation, interpolation with position detection function, fixed speed feed, fixed length feed
	Phase Control	Yes
Position Control	Reference Unit	mm, inch, deg, pulse
	Reference Unit Minimum Setting	1, 0.1, 0.01, 0.001, 0.0001, 0.00001
	Maximum Programmable Value	-2147483648 to +2147483647 (signed 32-bit value)
	Speed Reference Unit	mm/min, inch/min, deg/min, pulse/min
	Acceleration/Deceleration Type	Linear, asymmetric, S-curve
	Override Function	0% to 327.67% (in increments of 0.01%)
Coordinate System		Rectangular coordinates
Zero Point Return		Eight types <ul style="list-style-type: none"> • DEC1 + Phase C • DEC2 + Phase C • DEC1 + LMT • Phase C • DEC1 + ZERO • DEC2 + ZERO • DEC1 + LMT + ZERO • ZERO
Programs	Language	Special motion language
	Number of Tasks	Up to eight programs can be executed in parallel.
	Number of Programs	Up to 32
	Program Capacity	80 Kbytes
Applicable SERVOPACK		Analog: SGDH-□□AE
Encoder		Incremental or absolute
Speed Control	Speed Reference	-327.68 to +327.67 %/Rated speed With torque limit function
	Acceleration/Deceleration Type	Linear, asymmetric, S-curve (moving average)

2.3.2 PLC Function Specifications

Item		Specification
Torque Control	Torque Reference	-327.68 to +327.67 %/Rated torque With speed limit function
Phase Control	Speed Reference Unit	-327.68 to +327.67 %/Rated speed
	Speed Compensation	-327.68 to +327.67 %/Rated speed
	Position Compensation	-2147483648 to +2147483647 pulses
Commands		Axis Move Commands: 5 commands MOV, MVS, ZRN, SKP, EXM Basic Control Commands: 5 commands ABS, INC, POS, MVM, PLD Speed and Acceleration/Deceleration Commands: 8 commands ACC, DCC, SCC, VEL, IAC, IDC, IFP, FMX High-level Control Commands: 4 commands PFN, INP, SNG, UFC Control Commands: 10 commands MSEE, TIM, IOW, END, RET, EOX, IF ELSE IEND, WHILE WEND, SFORK JOINTO SJOINT Math and Sequence Control Commands: 32 commands =, +, -, *, /, MOD, , ^, &, !, (), S {}, R {}, SIN, COS, TAN, ASN, ACS, ATN, SQRT, BIN, BCD, ==, <>, >, <, >=, <=, SFR, SFL, BLK, CLR

2.3.2 PLC Function Specifications

The following table lists the PLC function specifications.

Table 2.4 PLC Function Specifications

Item	Specifications
Program Capacity	Equivalent to 2 Ksteps (varies according to amount of motion program used; 40 Ksteps max.)
Control Method	Sequence: scan methods
Programming Language	CP language Ladder logic diagram: Relay circuit Text-type language: Numeric operations, logic operations, etc.
Scanning	Time slicing within servo-control scan (S scan) period. Servo-control scan time setting: 0.5 / 1.0 / 2.0 / 4.0 ms High-speed scan time 0.5 to 32.0 ms (0.01-ms units); S-scan integer multiple setting: Low-speed scan time 2.0 to 100 ms (0.01-ms units); S-scan integer multiple setting:

Item	Specifications	
User Drawings, Functions, and Motion Programs	Start drawings (DWG.A): Servo-control scan process drawings (DWG.S): High-speed scan process drawings (DWG.H): Low-speed scan process drawings (DWG.L): Interrupt processing drawings (DWG.I): Number of steps: User functions: Motion programs: Revision history of drawings and motion programs Security function for drawings and motion programs	4 drawings max. Up to three hierarchical drawing levels. 16 drawings max. Up to three hierarchical drawing levels. 16 drawings max. Up to three hierarchical drawing levels 32 drawings max. Up to three hierarchical drawing levels 8 drawings max. Up to three hierarchical drawing levels Up to 500 steps per drawing Up to 32 functions Up to 32 Up to 32 functions Up to 32
Data Memory	Common data (M) registers: System (S) registers: Drawing local (D) registers: Drawing constant (#) registers: Input (I) registers: Output (O) registers: Constant (C) registers:	32 Kwords 1 Kwords Up to 16 Kwords per drawing Up to 16 Kwords per drawing 2 Kwords (including internal input registers) 2 Kwords (including internal output registers) 32 Kwords
Trace Memory	Data trace:	4 Kwords (4 Kwords x 1 group)
Memory Backup	Program memory:	CMOS battery backup
Data Types	Bit (relay): Integer: Double integer: Real number:	ON/OFF -32768 to +32767 -2147483648 to +2147483647 $\pm (1.175E - 38 \text{ to } 3.402E + 38)$
Register Designation Method	Register number: Symbolic designation:	Direct designation of register number Up to 8 alphanumeric characters (up to 200 symbols per drawing) With automatic number or symbol assignment
Instructions	Program control instructions: Direct I/O instructions: Relay circuit instructions: Logic operation instructions: Numeric operation instructions: Numeric conversion instructions: Numeric comparison instructions: Data manipulation instructions: Basic function instructions: Table data manipulation instructions: DDC instructions: System functions:	14 instructions 2 instructions 14 instructions (including set and reset coils) 3 instructions 16 instructions 9 instructions 7 instructions 14 instructions 10 instructions 11 instructions 13 instructions 6 instructions

2.3.3 Motion Command Descriptions

The following table describes the motion commands.

Table 2.5 Motion Command Descriptions.

Classification	Command	Name	Programming Format	Function/Meaning
Axis Move Commands	MOV	POSITIONING	MOV [axis1] – ; *	Executes positioning at rapid traverse speed.
	MVS	LINEAR INTERPOLATION	MVS [axis1] – F – ;	Executes linear travel at interpolation feed speed F.
	ZRN	ZERO POINT RETURN	ZRN [axis1] – ;	Returns axis to its zero point.
	SKP	SKIP	SKP [axis1] – SS – F – ;	If the SKIP signal turns ON during a linear interpolation operation, skips the remaining movement and proceeds to the next block.
	EXM	EXTERNAL POSITIONING	EXM [axis1] – D – ;	When an external positioning signal is input while external positioning is being executed, only the travel distance designated by "D-" is positioned with an incremental value, and then the next command is executed.
Basic Control Commands	ABS	ABSOLUTE MODE	ABS;	Treats all subsequent coordinate words as absolute values.
	INC	INCREMENTAL MODE	INC;	Treats all subsequent coordinate words as incremental values.
	POS	CURRENT POSITION SET	POS [axis1] – ;	Changes the current values to the desired coordinate values. Subsequent move commands use this new coordinate system.
	MVM	MOVE ON MACHINE COORDINATE	MVM MOV [axis1] – ; or MVM MVS [axis1] – ;	Goes to the target position on the machine coordinate system. The coordinate system set automatically on completion of the zero point return is called a machine coordinate system. This coordinate system is not affected by the POS command.
	PLD	PROGRAM CURRENT POSITION UPDATE	PLD [axis1] ;	Updates the program current position for axes shifted by manual intervention.

* “ – ” in MOV[axis1] – •••; denotes the numeric data for axis 1.

Classification	Command	Name	Programming Format	Function/Meaning
Speed and Acceleration/Deceleration Commands	ACC	ACCELERATION TIME CHANGE	ACC [axis1] – ;	Sets the acceleration time for linear acceleration/deceleration.
	DCC	DECELERATION TIME CHANGE	DCC [axis1] – ;	Sets the deceleration time for linear acceleration/deceleration.
	SCC	S-CURVE TIME CONSTANT CHANGE	SCC [axis1] – ;	Sets the time constant for moving average acceleration/deceleration.
	VEL	SET VELOCITY	VEL [axis1] – ;	Sets the feed speed.
	IAC	INTERPOLATION ACCELERATION TIME CHANGE	IAC T – ;	Sets the acceleration time for linear acceleration/deceleration for interpolation travel.
	IDC	INTERPOLATION DECELERATION TIME CHANGE	IDC T – ;	Sets the deceleration time for linear acceleration/deceleration for interpolation travel.
	IFP	INTERPOLATION FEED SPEED RATIO SETTING	IFP P – ;	Designates the maximum feed % for the speed designation during an interpolation feed.
	FMX	MAXIMUM INTERPOLATION FEED SPEED SETTING	FMX T – ;	Sets the maximum speed during an interpolation feed. The interpolation acceleration time is the time from zero until this speed is reached.
High-level Control Commands	PFN	IN-POSITION CHECK	MVS [axis1] – PFN; or PFN [axis1] ;	Proceeds to the next block after the positioning commanded by the interpolation travel command in the same block or a previous block enters the positioning completion range (parameter setting).
	INP	SECOND IN-POSITION CHECK	INP [axis1] – [axis2] – ...;	
	SNG	IGNORE SINGLE BLOCK SIGNAL	SNG MVS [axis1]100. [axis2]200. F1000;	A block with this command will be executed continuously, even in single-block operation mode. SNG cannot be designated on its own.
	UFC	USER FUNCTION CALL	UFC Function_name Input_data, Input_address, Output_data;	Calls a function created by the user.

Classification	Command	Name	Programming Format	Function/Meaning
Sequence Commands	=	SUBSTITUTE	(Result) = (Arithmetic expression)	Substitutes operation results. Performs calculations from left to right (with no order of priority).
	+	ADD	MW — = MW — + MW — ; MW — = MW — + 123456; MW — = 123456 + MW — ;	Performs integer and real number addition. Calculates combinations of integers and real numbers as real numbers.
	-	SUBTRACT	MW — = MW — - MW — ; MW — = MW — - 123456; MW — = 123456 - MW — ;	Performs integer and real number subtraction. Calculates combinations of integers and real numbers as real numbers.
	*	MULTIPLY	MW — = MW — * MW — ; MW — = MW — * 123456; MW — = 123456 * MW — ;	Performs integer and real number multiplication. Calculates combinations of integers and real numbers as real numbers.
	/	DIVIDE	MW — = MW — /MW — ; MW — = MW — /123456; MW — = 123456 /MW — ;	Performs integer and real number division. Calculates combinations of integers and real numbers as real numbers.
	MOD	REMAINDER	MW — = MW — /MW — ; MW — = MOD;	When programmed in the next block after a division, MOD stores the remainder in the designated register.
		OR (logical OR)	MB — = MB — MB — ; MB — = MB — 1; MW — = MW — MW — ; MW — = MW — H00FF;	Performs bit/integer logical OR.
	^	XOR (logical exclusive OR)	MW — = MW — ^ MW — ; MW — = MW — ^ H00FF;	Performs integer logical exclusive OR.
	&	AND (logical AND)	MB — = MB — & MB — ; MB — = MB — & 1; MW — = MW — & MW — ; MW — = MW — & H00FF;	Performs bit/integer logical AND.
	!	NOT (logical complement)	MB — = !MB — ; MB — = !1; MW — = !MW — ; MW — = !H00FF;	Performs bit/integer logical complement (inverts bits).
	()	PARENTHESSES	MW — = MW— & (MW— MW—);	The logical arithmetic expression inside parentheses is calculated first.
	S{ }	SET BIT	S{MB — } = MB — & MB — ;	If the logical operation result is "true," the designated bit turns ON. The designated bit does not turn OFF, even if the logical operation result is "false."
	R{ }	RESET BIT	R{MB — } = MB — & MB — ;	If the logical operation result is "true," the designated bit turns OFF. The designated bit does not turn ON, even if the logical operation result is "false."
	SIN	SINE	SIN(MW —) ; SIN(90) ;	Obtains the sine of the integer or real number (deg), and returns a real value.
COS	COSINE	COS(MW —) ; COS(90) ;	Obtains the cosine of the integer or real number (deg), and returns a real value.	

Classification	Command	Name	Programming Format	Function/Meaning
Se- quence Com- mands	TAN	TANGENT	TAN(MF —) ; TAN(45.0) ;	Obtains the tangent of the real number (deg), and returns a real value.
	ASN	ARC SINE	ASN(MF —) ; ASN(90.0) ;	Obtains the arc sine of the real number (deg), and returns a real value.
	ACS	ARC COSINE	ACS(MF —) ; ACS (90.0);	Obtains the arc cosine of the real number (deg), and returns a real value.
	ATN	ARC TANGENT	ATN(MW —) ; ATN (45) ;	Obtains the arc tangent of the integer or real number (deg), and returns a real value.
	SQT	SQUARE ROOT	SQT(MW —) ; SQT(100) ;	Obtains the square root of the integer or real number, and returns a real value.
	BIN	BCD-TO-BINARY	BIN (MW —) ;	Converts BCD data to binary data.
	BCD	BINARY-TO-BCD	BCD (MW —) ;	Converts binary data to BCD data.
	==	MATCH	IF MW — == MW — ; WHILE MW — == MW — ;	Used in an IF or WHILE conditional expression. If the left side and right side match, the condition is "true."
	<>	MISMATCH	IF MW — <> MW — ; WHILE MW — <> MW — ;	Used in an IF or WHILE conditional expression. If the left side and right side do not match, the condition is "true."
	>	GREATER THAN	IF MW — > MW — ; WHILE MW — > MW — ;	Used in an IF or WHILE conditional expression. If the left side is greater than the right side, the condition is "true."
	<	LESS THAN	IF MW — < MW — ; WHILE MW — < MW — ;	Used in an IF or WHILE conditional expression. If the left side is less than the right side, the condition is "true."
	>=	GREATER THAN OR EQUAL TO	IF MW — >= MW — ; WHILE MW — >= MW — ;	Used in an IF or WHILE conditional expression. If the left side is greater than or equal to the right side, the condition is "true."
	<=	LESS THAN OR EQUAL TO	IF MW — <= MW — ; WHILE MW — <= MW — ;	Used in an IF or WHILE conditional expression. If the left side is less than or equal to the right side, the condition is "true."
	SFR	RIGHT SHIFT	SFR MB — N — W — ;	Shifts only the designated number of word variables to the right.
	SFL	LEFT SHIFT	SFL MB — N — W — ;	Shifts only the designated number of word variables to the left.
	BLK	BLOCK MOVE	BLK MW — MW — W — ;	Moves the block (constant designation) beginning with the designated bit (word) variable.
CLR	CLEAR	CLR MB — W — ;	Sets the number of constants specified in the variable group beginning with the designated bit (word) variable to OFF ("0").	



2.3.3 Motion Command Descriptions

Classification	Command	Name	Programming Format	Function/Meaning
Control Commands	MSEE	SUBROUTINE CALL	MSEE MPS — ;	Executes the MPS- subroutine.
	TIM	DWELL TIME	TIM T — ;	Waits for the period of time specified by T, and then proceeds to the next block.
	IOW	I/O WAIT	IOW MB — == ***;	Stops execution of the motion program until the conditional expression given in the command is satisfied.
	END	PROGRAM END	END;	Ends the motion program.
	RET	SUBROUTINE RETURN	RET;	Ends the subroutine.
	EOX	ONE SCAN WAIT	EOX;	Separates continuous sequence instructions and forces a wait of one scan before continuing execution.
	IF ELSE IEND	Branching commands	IF (conditional expression) ; (process 1) ELSE; (process 2) IEND;	Executes process 1 if the conditional expression is satisfied, and executes process 2 if the conditional expression is not satisfied.
	WHILE WEND	Repeat commands	WHILE (conditional expression) ; ... WEND;	Repeatedly executes WHILE to WEND processing for as long as the conditional expression is satisfied.
	SFORK JOINTO SJOINT	Selective execution commands	SFORK conditional expression 1? label 1, Conditional expression 2? label 2, ...; Label 1: Process 1 JOINTO label X Label 2: Process 2 JOINTO label X Label · · Label X: SJOINT;	Executes process 1 if conditional expression 1 is satisfied, and executes process 2 if the conditional expression 2 is satisfied.

2.3.4 Ladder Instructions and Standard System Functions

The following table lists the ladder instructions and standard system functions.

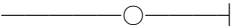
Table 2.6 Ladder Instructions and Standard System Functions

Type	Name	Symbol	Description
Program Control Instructions	CHILD DRAWING CALL	SEE	Designate the child drawing number or the grandchild drawing number to be called after SEE. SEE H01
	MOTION PROGRAM CALL	MSEE	Designate the motion program number and the MSEE work register address to be called after MSEE. MSEE MPM001 DA00000
	FOR Structure	FOR : : FEND	Repeats execution statement 1 FOR V = a to b by c V: Can designate any integer register I or J. a, b, c: Can designate an any integer value ($b > a > 0$, $c > 0$). FEND: End of FOR instruction.
	WHILE Structure	WHILE : ON/OFF : WEND	Repeats execution statement 2 WEND: End of WHILE-ON/OFF instruction
	IF Structure	IFON/IF-OFF : ELSE : IEND	Conditional execution statement IEND: End of IFON/IFOFF instruction
	DRAWING END	DEND	End of drawing (DWG)
	COMMENT	"nnnnnnn"	A character string enclosed in quotation marks is treated as a comment.
	FUNCTION CALL	FSTART	Calls a function.
	FUNCTION INPUT	FIN	Function input instruction Stores input data from the designated input register in the function input register.
	FUNCTION OUTPUT	FOUT	Function output instruction Stores output data from the function output register in the designated output register.
	XCALL	Calls an extension program.	
Direct I/O Instructions	INPUT STRAIGHT	INS	INS MA00100  Executes the input and storage of data with interrupts disabled.
	OUTPUT STRAIGHT	OUTS	OUTS MA00100  Executes the setting and output of data with interrupts disabled.

Type	Name	Symbol	Description
Relay Circuit Instructions	NO CONTACT		No limit in a series circuit. Bit designation of any register as a relay number is possible.
	NC CONTACT		No limit in a series circuit. Bit designation of any register as a relay number is possible.
	RISING PULSE		No limit in a series circuit. Bit designation of any register as a relay number is possible.
	FALLING PULSE		No limit in a series circuit. Bit designation of any register as a relay number is possible.
	10-MS ON-DELAY TIMER		Set value: Timer register Set value = Any register or constant (setting unit: 10 ms) Timer register = M or D register
	10-MS OFF-DELAY TIMER		Set value: Timer register Set value = Any register or constant (setting unit: 10 ms) Timer register = M or D register
	1-S ON-DELAY TIMER		Set value: Timer register Set value = Any register or constant (setting unit: 1 s) Timer register = M or D register
	1-S OFF-DELAY TIMER		Set value: Timer register Set value = Any register or constant (setting unit: 1 s) Timer register = M or D register
	COIL		
	SET COIL		
RESET COIL			
Branching/convergence		A branching or convergence symbol can be connected to any of the above relay instructions.	
Logic Operation Instructions	AND	\wedge	Integer designation of any register or constant is possible.
	OR	\vee	Integer designation of any register or constant is possible.
	XOR	\oplus	Integer designation of any register or constant is possible.
	ADDITION	+	Ordinary numeric addition (with operation error) $\vdash MW00280 + 00100 \Rightarrow MW00220$
	SUBTRACTION	-	Ordinary numeric subtraction (with operation error) $\vdash MW00280 - 00100 \Rightarrow MW00220$
	EXTENDED ADDITION	++	Closed numeric addition (without operation error) $0 \rightarrow 32767 \rightarrow -32768 \rightarrow 0$
	EXTENDED SUBTRACTION	--	Closed numeric subtraction (without operation error) $0 \rightarrow -32768 \rightarrow -32767 \rightarrow 0$

Type	Name	Symbol	Description
Numeric Operation Instructions	INTEGER ENTRY	\vdash	Starts an integer operation. \vdash MW00280 + 00100 \Rightarrow MW00220
	REAL NUMBER ENTRY	$\parallel\vdash$	Starts a real number operation. $\parallel\vdash$ MW00280 + 00100 \Rightarrow MW00220
	STORE	\Rightarrow	Stores the operation result in the designated register.
	MULTIPLICATION	\times	For integer and long integers, use \times and \div in combination.
	DIVISION	\div	
	INCREMENT	INC	Adds 1 to the designated register. INC MW00100
	DECREMENT	DEC	Subtracts 1 from the designated register. DEC MW00100
	MOD	MOD	Gets the remainder of the division result. \vdash MW00100 \times 01000 \div 00121 MOD \Rightarrow MW00101
	REM	REM	Gets the remainder of the division result. MF00200 REM 1.5 \Rightarrow MF00202
	ADD TIME	TMADD	Addition of hours, minutes, and seconds TMADD MW00000, MW00100
	SUBTRACT TIME	TMSUB	Subtraction of hours, minutes, and seconds TMSUB MW00000, MW00100
	SPEND TIME	SPEND	Calculates the elapsed time between two times. SPEND MW00000, MW00100

2.3.4 Ladder Instructions and Standard System Functions

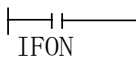
Type	Name	Symbol	Description
Numeric Conversion Instructions	SIGN INVERSION	INV	┆ MW00100 INV If MW00100 = 99, the operation result = -99.
	1'S COMPLEMENT	COM	┆ MW00100 CON If MW00100 = FFFFH, the operation result = 0000H.
	ABSOLUTE VALUE CONVERSION	ABS	┆ MW00100 ABS If MW00100 = -99, the operation result = 99.
	BINARY CONVERSION	BIN	┆ MW00100 BIN If MW00100 = 1234H (hexadecimal), the operation result = 1234 (decimal).
	BCD CONVERSION	BCD	┆ MW00100 BCD If MW00100 = 1234 (decimal), the operation result = 1234H (hexadecimal).
	PARITY CONVERSION	PARITY	Calculates the number of binary bits that are ON. If MW00100 = F0F0H, the operation result = 8.
	ASCII CONVERSION 1	ASCII	The designated character string is converted to ASCII code and substituted in the register. MW00200 "ABCDEFGH"
	ASCII CONVERSION 2	BINASC	Converts 16-bit binary data to 4-digit hexadecimal ASCII code. BINASC MW00100
	ASCII CONVERSION 3	ASCBIN	Converts the numeric value indicated by a 4-digit hexadecimal ASCII code to 16-bit binary data. ASCBIN MW00100
Numeric Comparison Instructions	<	<	Leaves ON/OFF in B register for comparison instruction results. $\begin{array}{c} \text{MB000010} \\ \text{┆ MW00000} < 10000 \text{ ┆} \text{○} \text{┆} \\ \text{MB000010} \end{array}$ 
	≤	≤	
	=	=	
	≠	≠	
	≥	≥	
	>	>	
	RANGE CHECK	RCHK	Checks whether or not the value in the A register is in range. ┆ MW00100 RCHK -1000, 1000

Type	Name	Symbol	Description
Data Operation Instructions	BIT ROTATION RIGHT	ROTR	Bit-addr Count Width ROTR MB00100A → N=1 W=20
	MOVE BITS	MOVB	Source Desti. Width MOVB MB00100A → MB00200A W=20
	MOVE WORD	MOVW	Source Disti. Width MOVW MB00100 → MB00200 W=20
	EXCHANGE	XCHG	Source1 Source2 Width XCHG MB00100 → MB00200 W=20
	SET WORDS	SETW	Desti. Data Width SETW MW00200 D=00000 W=20
	BYTE-TO-WORD EXPANSION	BEXTD	Expands the byte data stored in the word registers into words. BEXTD MW00100 to MW00200 B=10
	WORD-TO-BYTE COMPRESSION	BPRESS	Collects the lower bytes of the word data stored in the word register area. BPRESS MW00100 to MW00200 B=10
	BINARY SEARCH	BSRCH	Retrieves the register position that matches the data within the designated register range. BSRC MW00000 W=20 D=100 R=MW00100
	SORT	SORT	Sorts registers within the designated register range. SORT MW00000 W=100
	BIT SHIFT LEFT	SHFTL	Shifts the designated bit strings to the left. SHFTL MB00100A N=1 W=20
	BIT SHIFT RIGHT	SHFTR	Shifts the designated bit strings to the right. SHFTR MB00100A N=1 W=2
	COPY WORD	COPYW	Copies the designated register range. COPYW MW00100 → MW00200 W=20
BYTE SWAP	BSWAP	The upper and lower bytes of the designated word are swapped. BSWAP MW00100	

Type	Name	Symbol	Description
Basic Function Instructions	SQUARE ROOT	SQRT	Taking the square root of a negative number results in the square root of the absolute value multiplied by -1. - MF00100 SQRT
	SINE	SIN	Input = degrees - MF00100 SIN
	COSINE	COS	Input = degrees - MF00100 COS
	TANGENT	TAN	Input = degrees - MF00100 TAN
	ARC SINE	ASIN	- MF00100 ASIN
	ARC COSINE	ACOS	- MF00100 ACOS
	ARC TANGENT	ATAN	- MF00100 ATAN
	EXPONENT	EXP	- MF00100 EXP e MF00100
	NATURAL LOGARITHM	LN	- MF00100 LN \log_e (FM00100)
	COMMON LOGARITHM	LOG	- MF00100 LOG \log_{10} (FM00100)

Type	Name	Symbol	Description
DDC Instructions	DEAD ZONE A	DZA	┌ MW00100 DZA 00100
	DEAD ZONE B	DZB	┌ MW00100 DZB 00100
	UPPER LIMIT	LIMIT	┌ MW00100 LIMIT -00100 00100
	PI CONTROL	PI	┌ MW00100 PI MA00200
	PD CONTROL	PD	┌ MW00100 PD MA00200
	PID CONTROL	PID	┌ MW00100 PID MA00200
	FIRST-ORDER LAG	LAG	┌ MW00100 LAG MA00200
	PHASE LEAD/ LAG	LLAG	┌ MW00100 LLAG MA00200
	FUNCTION GENERATOR	FGN	┌ MW00100 FGN MA00200
	INVERSE FUNCTION GENERATOR	IFGN	┌ MW00100 IFGN MA00200
	LINEAR ACCELERATOR/ DECELERATOR 1	LAU	┌ MW00100 LAU MA00200
	LINEAR ACCELERATOR/ DECELERATOR 2	SLAU	┌ MW00100 SLAU MA00200
	PULSE WIDTH MODULATION	PWM	┌ MW00100 PWM MA00200
Table Data Operation Instructions	TABLE READ	TBLBR	TBLBR TBL1, MA00000, MA00100
	TABLE WRITE	TBLBW	TBLBW TBL1, MA00000, MA00100
	ROW SEARCH	TBLSRL	TBLSRL TBL1, MA00000, MA00100
	COLUMN SEARCH	TBLSRC	TBLSRC TBL1, MA00000, MA00100
	TABLE CLEAR	TBLCL	TBLCL TBL1, MA00000
	TABLE BLOCK MOVE	TBLMV	TBLMV TBL1, TBL2, MA00000
	QUEUE TABLE READ	QTBLR	QTBLR TBL1, MA00000, MA00100
	QUEUE TABLE READ AND INCREMENT	QTBLRI	QTBLRI TBL1, MA00000, MA00100
	QUEUE TABLE WRITE	QTBLW	QTBLW TBL1, MA00000, MA00100
	QUEUE TABLE WRITE AND INCREMENT	QTBLWI	QTBLWI TBL1, MA00000, MA00100
	QUEUE POINTER CLEAR	QTBLCL	QTBLCL TBL1

Type	Name	Symbol	Description
Standard System Functions	COUNTER	COUNTER	Increments or decrements a counter.
	FIRST-IN FIRST-OUT	FINFOUT	First-in, first-out
	TRACE	TRACE	Data trace execution control
	DATA TRACE READ	DTRC-RD	Data readout from data trace memory to user memory
	SEND MESSAGE	MSG-SND	Sending a message from a Communications Module
	RECEIVE MESSAGE	MSG-RCV	Receiving a message from a Communications Module

2.4 Main CP-717 Functions

The CP-717 is configured of five managers for managing and controlling the MP940 system. The main functions developed for each of these managers are shown in the following table.

Manager	Function	Description
File Manager		CP-717 system and file configuration is displayed in a tree structure, and various methods of file control are available. Online and offline control are both possible.
	File control	The folders and files required for the system configuration are organized in a tree structure.
	User administration	This is a user security function centered on log-on and log-off.
	File transfer	Transfers data between programming device and Machine Controller.
	Command startup	Starts tools.
Engineering Manager		Calls engineering tools, and can perform various monitoring operations when in online mode with the MP940.
	Command execution	Provides all programming device functions. File Manager can also be called.
	Definition settings	Defines Module configuration, systems, scan time, application data, data trace, groups, and motion parameters.
	Ladder logic programming	Provides a programming environment based on new production, properties, constant tables, I/O conversion tables, interlock tables, element assembly tables, and adjustment panels.
	Utilities	Provides register lists, cross references, disabled coil lists, comment lists, and register number replacement tools.
	Motion programming	Provides a motion programming environment based on the Motion Editor.
Print/List Manager	Print processing	Lists the jobs currently being printed and the jobs that are queued for printing. Can also cancel the print command.
User Menu Manager	Shortcut registration	Creates a shortcut icon on the desktop.
Communications Process Manager	Communications processing	Sets transfer parameters and manages communications with the MP940.

2.5 Function Tree Structure

The following diagram shows the commands started from each manager. With the CP-717 the File Manager Window is displayed first.

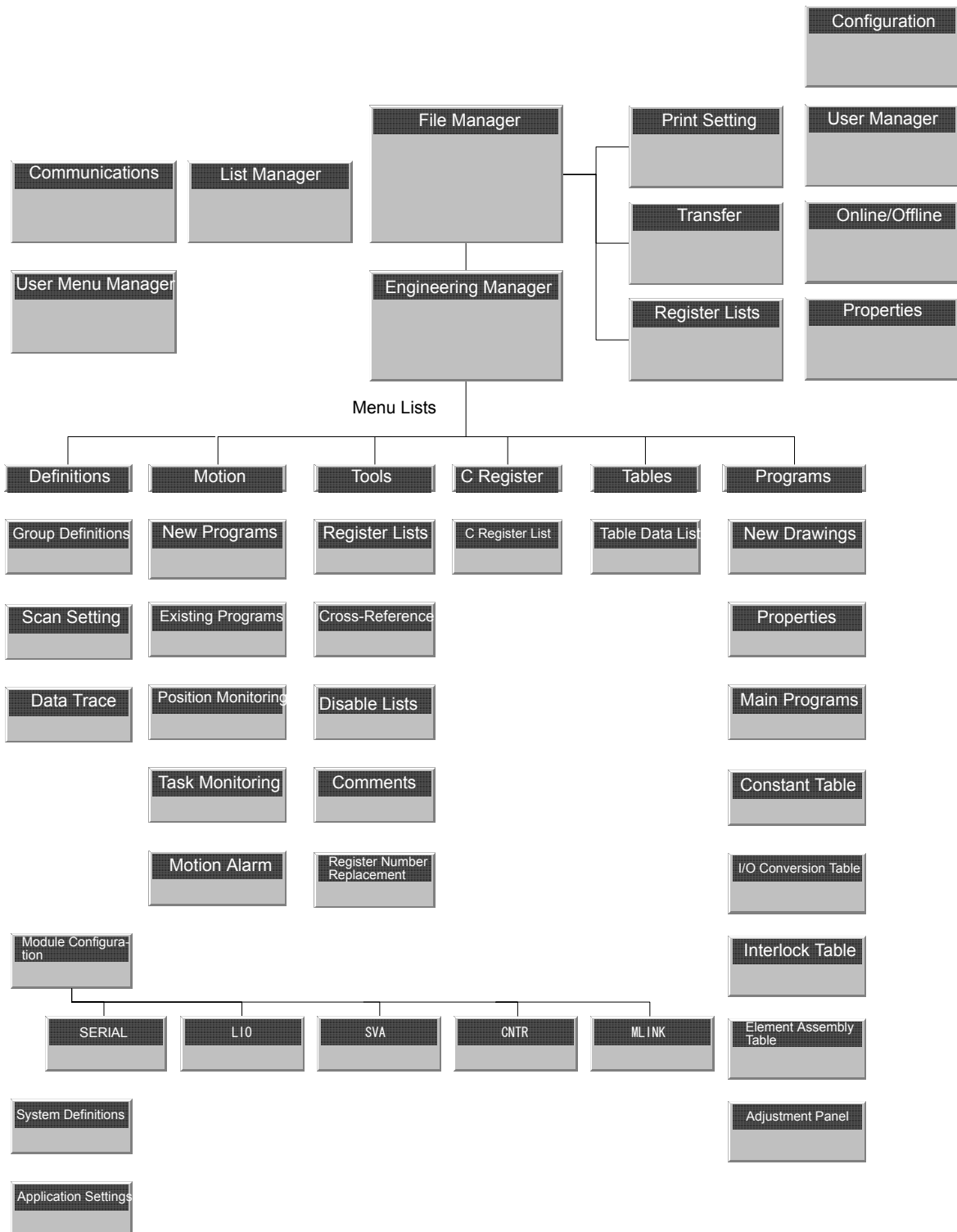

2.6 SERVOPACK Specifications

2.6.1 Outer Appearance and Nameplate Example

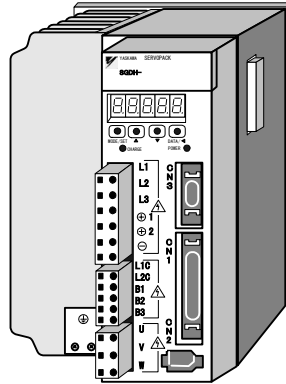

Σ-II Series
SGDH SERVOPACK

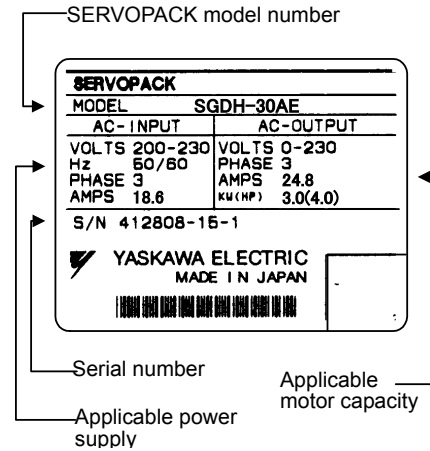

2

2.6.2 Model Numbers

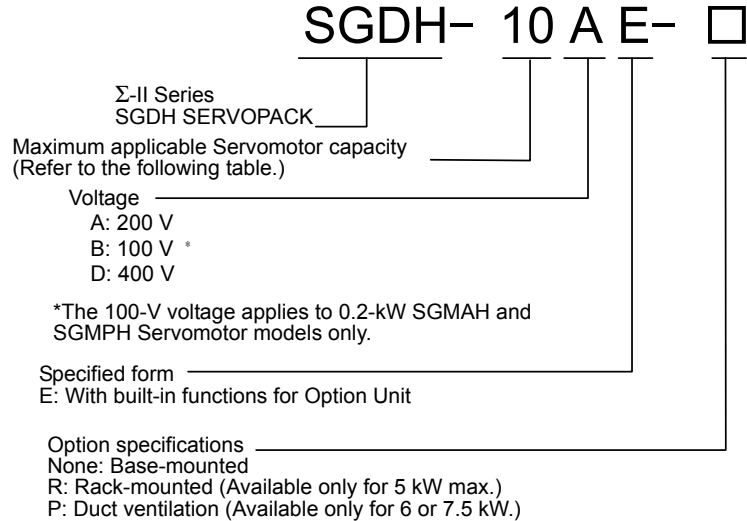

Max. Applicable Motor Capacity Symbol	Capacity (kW)	Max. Applicable Motor Capacity Symbol	Capacity (kW)
A3	0.03	08	0.75
A5	0.05	10	1.0
01	0.10	15	1.5
02	0.20	20	2.0
04	0.40	30	3.0
05	0.50		

Note: The only 100-V servomotor models are the SGMAH and SHMPH Servomotors of 0.2 kW or less.



For details on SERVOPACK and Servomotor specifications and functions, refer to Σ -II Series SGM□/SGDH User's Manual: Design and Maintenance (SIE-S800-32.2).

3 Basic System Operation

This chapter explains the basic operation of the MP940 system.

3.1 Operating Modes	3-3
3.1.1 Online Operating Mode	3-3
3.1.2 Offline Stop Mode	3-3
3.2 Start and Stop Sequences	3-5
3.2.1 DIP Switch Settings	3-5
3.2.2 Start Sequence	3-7
3.3 Scan Processing	3-10
3.3.1 Overview of Scan Processing	3-10
3.3.2 S Scan Details	3-11
3.3.3 Setting Scan Times	3-12
3.3.4 Setting the System Scan Time	3-13
3.3.5 Setting Scan Time Definitions	3-14
3.3.6 Saving Scan Time Definitions	3-15
3.3.7 Completing Scan Time Definitions	3-15
3.4 User Programs	3-16
3.4.1 Drawings (DWGs)	3-16
3.4.2 Execution Control of Parent Drawings	3-17
3.4.3 Motion Programming	3-20
3.5 Functions	3-28
3.5.1 Standard System Functions	3-28
3.5.2 Creating User Functions	3-29
3.5.3 Determining the I/O Specifications	3-29
3.5.4 Defining Function I/O	3-30
3.5.5 Creating the Body of the Function	3-31
3.5.6 Creating the Program that Calls the Function	3-32

3.6 Registers	3-34
3.6.1 Register Designation Methods	3-34
3.6.2 Data Types	3-35
3.6.3 Types of Register	3-38
3.6.4 Using Subscripts I and J	3-40
3.6.5 I/O and Registers in Functions	3-42
3.6.6 Register Ranges in Programs	3-43
3.7 Managing Symbols	3-44
3.7.1 Symbols in Drawings	3-44
3.7.2 Symbols in Functions	3-44
3.7.3 Upward Linking of Symbols	3-45
3.7.4 Automatic Register Number Allocation	3-45

3.1 Operating Modes

This section explains the online operating mode and the offline stop mode, both of which indicate the MP940 operating status.

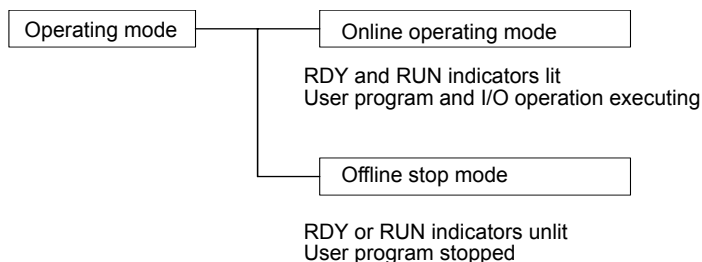

Fig 3.1 MP940 Operating Modes

3.1.1 Online Operating Mode

When the power for the MP940 is turned ON, the RDY and RUN indicators will light (the ALM indicators will not light), and the Module will enter the online operating mode. This means that the user program and I/O operations are being executed in the MP940 without any errors or failures. If an alarm does occur, such as for an I/O conversion error or a user calculation error, the execution of the user program will not stop, and the online operating mode will be maintained. The ALM indicator lights to indicate the occurrence of an error. For details on the error content and the action to be taken, see *Chapter 10 SERVOPACK Inspection, Maintenance, and Troubleshooting*.

3.1.2 Offline Stop Mode

The execution of the user program is stopped, and all outputs are reset (i.e., “0” is output for all digital outputs). The RUN or RDY indicator will go OFF to indicate the status. Drawings (DWG.H and DWG.L) are not executed in this status.

The Controller will be in the offline stop mode in the following four cases:

1. When the program memory has not been initialized (see * 1.)
2. When a serious failure, such as watchdog timer error, has occurred (see * 1.)
3. When a STOP operation has been performed from the CP-717 (see * 2.)
4. When the RUN/STOP switch has been set to OFF (STOP) and the power has been turned ON (see * 3.)

Note: 1. The above cases apply when a user program error occurs, or when there is a hardware fault in the MP940. For details on the error content and the action to be taken, see *Chapter 10 SERVOPACK Inspection, Maintenance, and Troubleshooting*.

2. The online operating mode is entered by performing a RUN operation.

3. The online operating mode is entered by turning ON (RUN) the RUN/STOP switch.

3.2 Start and Stop Sequences

This section explains the start and stop sequences of the MP940. The methods of setting the DIP switch, the types of self-diagnosis, and the indicator patterns are also explained.

3.2.1 DIP Switch Settings

The DIP switch on the CPU Module are used to control start and stop sequences. As shown in the following figure, there are six pins on the DIP switch on the CPU Module. The following table shows the function of each pin.

Table 3.1 DIP Switch Pin Functions

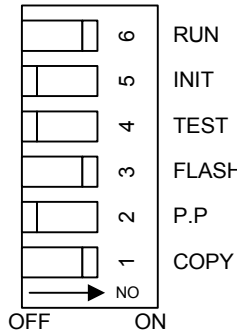

Pin	Name	Setting	Function	Default Setting
6	RUN	ON	User program operating	ON
		OFF	User program stopped	
5	INITIAL	ON	Pin 4 OFF: ON: Memory clear	OFF
		OFF	Pin 4 OFF: ON: Setting disabled	
4	TEST	ON	Terminal mode/initialization mode	OFF
		OFF	Online	
3	FLASH	ON	Copy program data from flash memory to RAM	ON
		OFF	Do not copy program data from flash memory to RAM	
2	PP Default	ON	Defaults for port 1 only	OFF
		OFF	Use memory settings	
1	COPY	ON	Copy M register from flash memory.	ON
		OFF	Do not copy M register from flash memory.	

IMPORTANT

- NO is indicated at the arrow at the lower right of the DIP switch. When a pin is moved to the right side it is ON, and when moved to the left it is OFF.
- If using the CPU Module without backup for the battery, be sure to set the pin no.5 (INITIAL) to ON.

Memory Initialization

When the DIP switch is set according to the following procedure and the power is turned ON and OFF, memory will be initialized, and the user programs and definition data will be deleted.

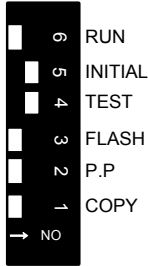
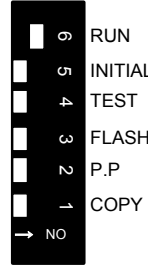
1	2	3	4	5
<p>Turn OFF the MP940 power.</p>	<p>Turn ON the DIP switch pins for INIT and TEST.</p> 	<p>Turn ON the power, and check that the RDY and RUN indicators flash, and then wait for 4 to 5 seconds (Flashes until the power is turned OFF).</p>	<p>Turn OFF the power, and return the DIP switch pins to their original settings, with only the RUN pin ON.</p> 	<p>Turn ON the power again.</p>

Always initialize memory if you remove the battery when the Module power supply is turned OFF.

3.2.2 Start Sequence

The MP940 makes a number of determinations at startup. If an error is detected, the ERR indicator will flash and the error content will be indicated by the number of times the indicator flashes. When the indicator is flashing, the CP-717 cannot be operated. For details on the error content and the action to be taken, see *Chapter 10 SERVOPACK Inspection, Maintenance, and Troubleshooting*. The following table shows the MP940 indicators.

Table 3.2 Indicators and Indicator Patterns

Type	Indicator				Meaning
	RDY	RUN	ALM	BAT	
Normal	Lit	Unlit	Unlit	Unlit	The user program is stopped.
	Lit	Lit	Unlit	Unlit	The user program is executing normally.
Error	Unlit	Unlit	Lit	Unlit	Hardware reset status (while display is continuing)
	Unlit	Unlit	Unlit	Unlit	During initial execution (while display is continuing)
	Unlit	-	Lit	Unlit	A serious error has occurred.
	Unlit	Unlit	Flashing	Unlit	<ul style="list-style-type: none"> • Flashing twice: RAM error • Flashing three times: ROM error • Flashing four times: Peripheral LSI error
Alarm	-	-	-	Lit	Battery alarm
	Lit	Lit	Lit	Unlit	<ul style="list-style-type: none"> • Calculation error • I/O error
	Reported to the system (S) register (no indicator display)				Hardware status (power loss, RUN/STOP, test mode, etc.)
Other	Flashing	Flashing	Unlit	Unlit	Memory initialization has been completed for the DIP switch settings.
	RDY and RUN flash repeatedly at the same time.				
	Unlit	Unlit	Lit	Unlit	Offline test mode

■ MP940 Start Sequence and Basic Operation

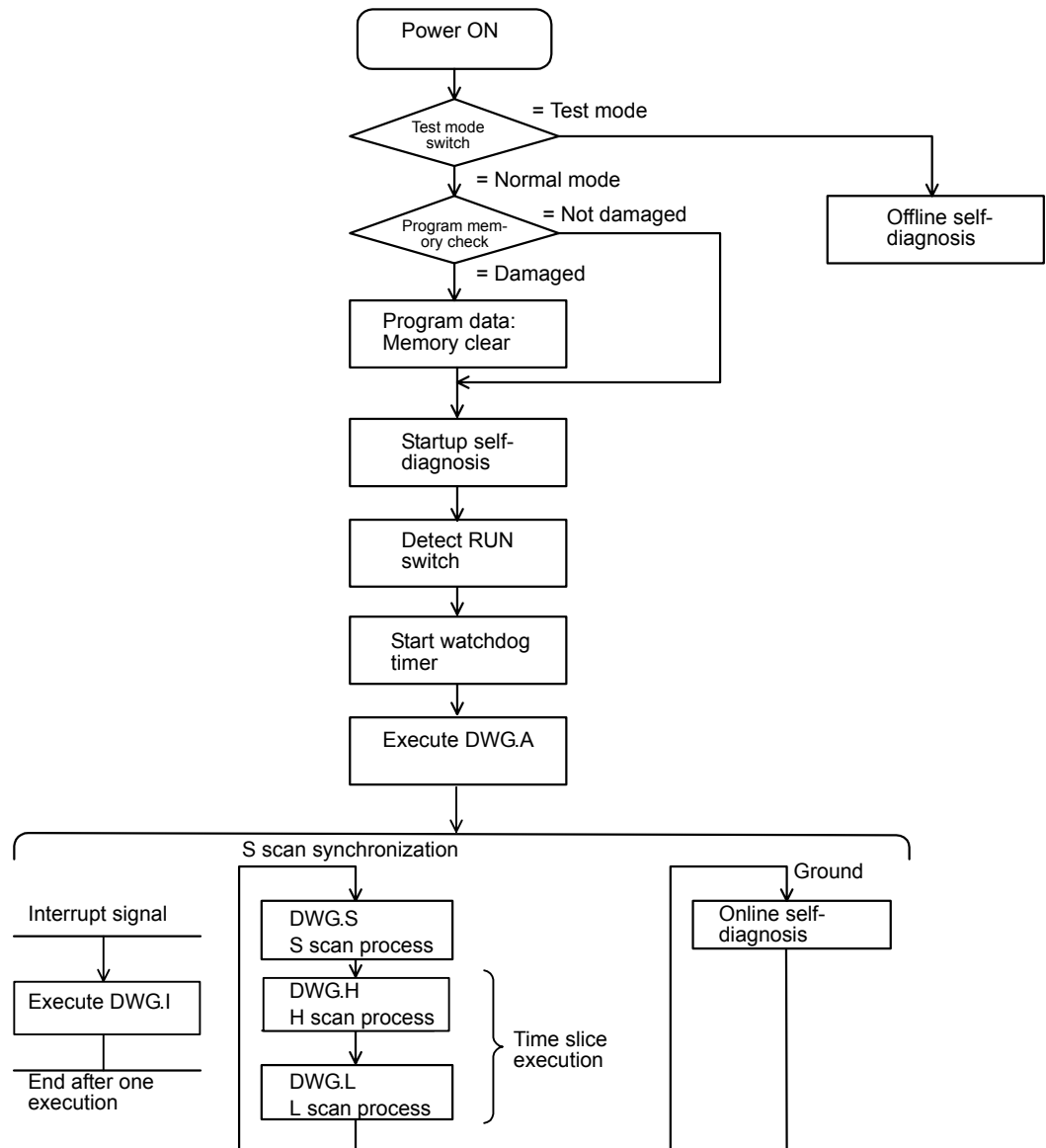

The MP940 start sequence and basic operations are as follows:

1. Startup Self-diagnosis

The following operations are provided for startup self-diagnosis:

- Memory (RAM) read/write diagnosis
- System program (ROM) diagnosis
- Main processor (CPU) function diagnosis
- Numeric co-processor (FCPU) function diagnosis

If an error occurs in the diagnostic result, the RDY indicator will flash the specified number of times.

2. Online Self-diagnosis

The following operations are provided for online self-diagnosis:

- System program (ROM) diagnosis
- Main processor (CPU) function diagnosis
- Numeric co-processor (FCPU) function diagnosis

If an error occurs in the diagnostic result, the RDY indicator will flash the specified number of times.

3. New Operation Start

Set the operation method for “New Operation” on the CP-717 System Definition Screen. When the system is next started, the new operation will be used to start. Unlike a continuous operation start, self-diagnostic processing is performed before DWG.A is executed.

4. Operation Stop

The MP940 stops operating in the following cases:

- When the power supply is interrupted (see * 1.)
- When a power failure has occurred (see * 1.)
- When a fatal error has occurred (see * 2.)
- When a STOP operation has been performed from the CP-717 (see * 3.)

Note: 1. The MP940 can be restarted only by turning ON the power again.

2. Restart the system by turning the power OFF and ON. The cause of the error can be ascertained by the indicator status.

3. Restart the system by performing a RUN operation from the CP-717.

3.3 Scan Processing

3.3.1 Overview of Scan Processing

There are three types of MP940 scan processing: S (system) scans, H (high-speed) scans, and L (low-speed) scans. Scan processing is executed using time slicing within the S-scan cycle, with the S scan as the basic cycle.

Background processing time for PP processing must be ensured by setting a ratio for allocation to background processing within the S scan cycle.

■ Types of Scans

Scan Type	Details
S scan (system scan)	<ul style="list-style-type: none"> Basic cycle for scan processing: Select 0.5, 1.0, 2.0, or 4.0 ms. S, H, and L scan processing is all executed with time slicing within the S-scan cycle.
H scan (high-speed scan)	<ul style="list-style-type: none"> Set as an integer multiple of S-scan cycle. Executed with time slicing within S-scan cycle.
L scan (low-speed scan)	<ul style="list-style-type: none"> Set as an integer multiple of S-scan cycle. Executed with time slicing within S-scan cycle.

■ Service Scans for Each Function

Except for SVA, the scan for executing I/O processing can be selected for each function.

Function	Scans Possible for Servicing	Remarks
CNTR	S/H/L	Processed in sync with S, H, or L.
LIO (DI/DO/AI/AO)	S/H/L	Processed in sync with S, H, or L.
MECHATROLINK (distributed I/O, etc.)	H/L	Processed in sync with H, or L.
SVA	S/H	<p>Scan fixed (not selectable).</p> <p>Parameters can be set to select synchronization with the Phase Control Mode and the Position Control Mode.</p> <p>Phase Control Mode Synchronization Selection (OBC0016) 0: H scan (default); 1: S scan</p> <p>Position Control Mode Parameter Synchronization Selection (OBC0017) 0: H scan; 1: S scan (default)</p>

3.3.2 S Scan Details

The following diagram shows the internal processing and order of processing of an S scan.

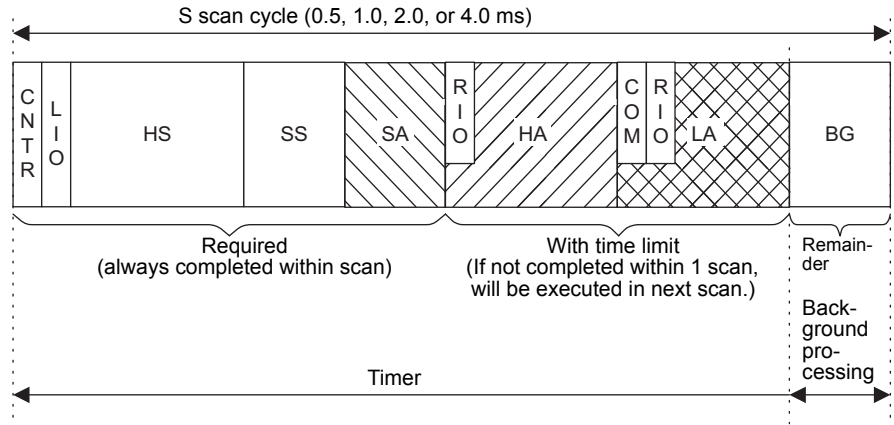

■ Items Always Completed within S Scan

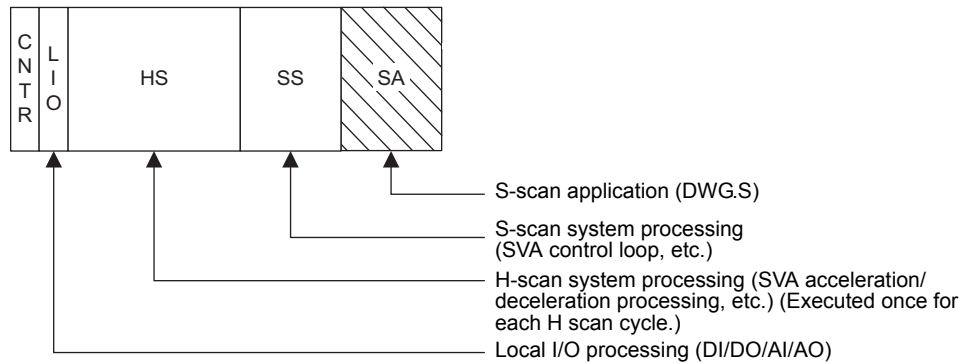

■ Timesharing Items

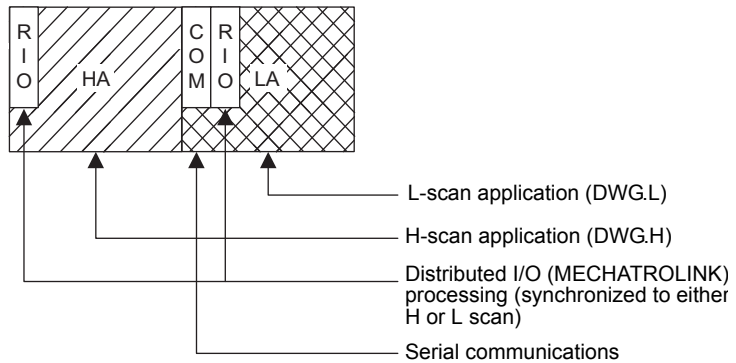

■ Background

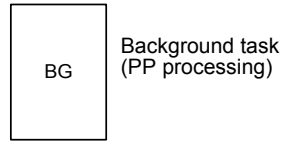

IMPORTANT

Precautions for Scan Processing

- When processing is to be completed within the S scan, have it completed in approximately 1/2 the time of the S-scan cycle setting.
- Set the ratio allocated to background processing.

■ Scan Operations

The various scan processing operations are as shown in the following diagram.

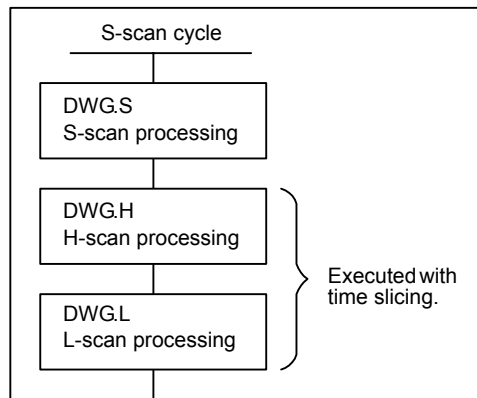

3.3.3 Setting Scan Times

■ Opening the Scan Time Settings Window

From the CP-717 File Manager, double-click on Scan Time Settings in the Definition Folder.

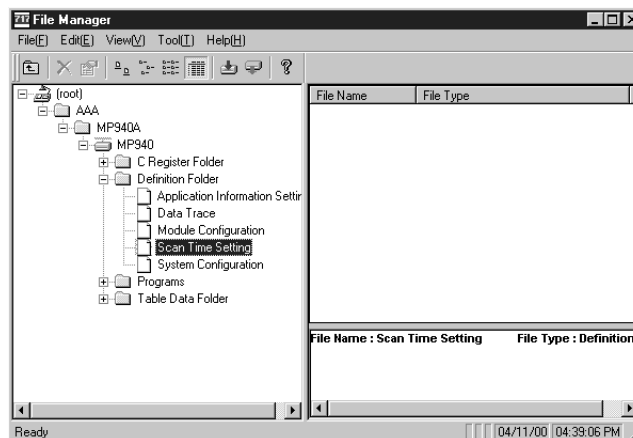

The Scan Time Settings Window will be displayed.

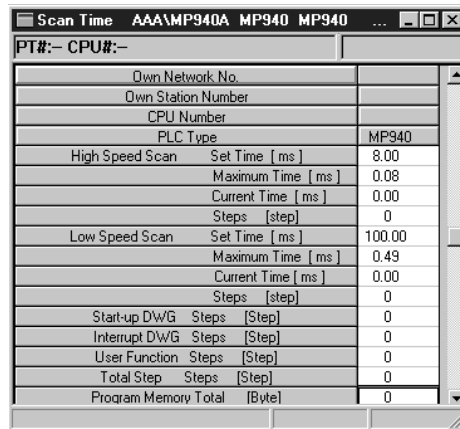

3.3.4 Setting the System Scan Time

The MP940 has three scan time levels (system, high-speed, and low-speed). The scan time setting determines the program execution flow. The system scan time must be set first, before the other two levels. The high-speed and low-speed scan times are set based on the system scan time.

The setting range for each of the three scan time levels is shown in the following table. For details, refer to the *MP940 User's Manual: Design and Maintenance Manual*.

Scan Time Level	Setting Range
System scan	0.5, 1, 2, or 4 ms
High-speed scan	0.5 to 32 ms (system scan integer multiple)
Low-speed scan	2.0 to 100 ms (system scan integer multiple)

■ Opening the Settings Window

Select **Settings (S)** and then **Basic Control Cycle (B)** from the **View (V)** Menu.

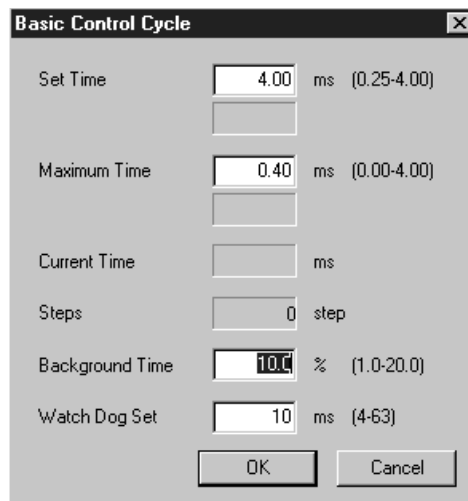

Setting	Details
Set Time	Sets the system scan time value. The lower number is the value that is currently set.
Maximum Time	Sets the maximum system scan time value. The lower number is the maximum valued measured by the system up to this point.
Current Time	Indicates the present value for the system scan time.
Number of Steps	Indicates the number of steps for the system scan time.
Background Time	Indicates the percentage of the overall system that is being used for background processing.
Watchdog Set	Sets a watchdog time which is the estimated time limit for the system scan.

IMPORTANT

- The power supply must first be turned OFF before changing the basic control cycle.
- Even when the memory is cleared, the basic control cycle will not be returned to the default value but the present value will be applied. To return to the default value, turn the power OFF and back ON again.

3.3.5 Setting Scan Time Definitions

PT#:- CPU#:-		
Own Network No.		
Own Station Number		
CPU Number		
PLC Type		MP940
High Speed Scan	Set Time [ms]	8.00
	Maximum Time [ms]	0.08
	Current Time [ms]	0.00
	Steps [step]	0
Low Speed Scan	Set Time [ms]	100.00
	Maximum Time [ms]	0.49
	Current Time [ms]	0.00
	Steps [step]	0
Start-up D/WG	Steps [Step]	0
Interrupt D/WG	Steps [Step]	0
User Function	Steps [Step]	0
Total Step	Steps [Step]	0
Program Memory Total	[Byte]	0

In the Online Mode, the Machine Controller's high-speed scan time will be displayed. In the Offline Mode, the scan time data saved on the hard disk will be displayed.

Setting	Details
High Speed Scan	Set Time: Input the set value for the scan time.
	Maximum Time: The maximum value for the scan time will be displayed. To reset the maximum scan time value, input 0. In the Offline Mode “0” is displayed.
	Current Time: The present value for the scan time will be displayed. In the Offline Mode “0” is displayed.
	Steps: The total number of steps for the scan processing drawing is displayed.
Low Speed Scan	Set the low-speed scan time. For the meaning of each data item, refer to the description under the high-speed scan time.
Start-up DWG Steps Process Drawing	The number of steps for the startup processing drawing is displayed.
Interrupt DWG Steps	The total number of steps for the interrupt processing drawing is displayed.
User Function Steps	The total number of steps for user functions is displayed.
Total Step Steps	The total number of steps for all drawings is displayed.
Program Memory	Total: The total amount of program memory used is displayed (i.e., the total for drawings, functions, and motion programs). In the Offline Mode “0” is displayed.
	Available: The remaining program memory is displayed. In the Offline Mode “0” is displayed.



In the Online Mode, the maximum scan time value can be cleared to 0 by entering “0” in the maximum value field and saving it. After the previous maximum value has been cleared, a new maximum value will begin to be determined.

3.3.6 Saving Scan Time Definitions

Use the following procedure to save a scan time definition.

1. Select **Save(S)** from the **File(F)** Menu.
2. Click the **Yes(Y)** Button in the Scan Time Message Box.
3. Click the **OK** Button in the message box.

3.3.7 Completing Scan Time Definitions

The scan time settings are completed by closing the Scan Time Window.

To close the window, select **Close(C)** from the **File(F)** Menu.

3.4 User Programs

This section explains the basic operation of the MP940, such as the types of user program, the priority levels, and the execution processing methods.

3.4.1 Drawings (DWGs)

User programs are managed in units of programming called drawings. Each drawing is identified by a drawing number (DWG No.). These drawings serve as the basis of user programs. The drawings include parent drawings, child drawings, grandchild drawings, and operation error drawings. Besides the drawings, there are functions that can be freely called from each drawing, and motion programs that can be called only from H drawings.

- Parent Drawings

Parent drawings are executed automatically by the system program when the execution condition is established. See the Types and Priority Levels of Parent Drawings Table below for execution conditions.

- Child Drawings

Child drawings are executed by being called from a parent drawing using the SEE command.

- Grandchild Drawings

Grandchild drawings are executed by being called from a child drawing using the SEE instruction.

- Operation Error Drawings

Operation error drawings are executed automatically by the system program when an operation error occurs.

- Functions

Functions are executed by being called from a parent, child, or grandchild drawing using the FSTART instruction.

- Motion Programs

Motion programs can be called only from H drawings. They can be executed by being called from a parent, child, or grandchild drawing using the MSEE instruction.

Types and Priority Levels of Parent Drawings

Parent drawings are classified by the first character of the drawing number (A, I, S, H, L) according to the purpose of the process. The priority levels and execution conditions are as shown in the following table.

Table 3.3 Types and Priority Levels of Parent Drawings

Type of Parent Drawing	Role of Drawing	Priority Level	Execution Condition	Number of Drawings
DWG.A	Startup process	1	Started when power is turned ON (executed once only when the power is turned ON)	4
DWG.I	Interrupt process	2	Executed by external interrupts, such as Optional Module DI interrupts or counter interrupts.	8

Type of Parent Drawing	Role of Drawing	Priority Level	Execution Condition	Number of Drawings
DWG.S	Servo-control scans	3	Fixed-cycle startup (Executed with each servo-control scan time.)	16
DWG.H	High-speed scan process	4	Servo-control scan (S scan) (Executed by time slicing within cycle.)	16
DWG.L	Low-speed scan process	5	Servo-control scan (S scan) (Executed by time slicing within cycle.)	32

The following table gives details of the number of drawings for each type of drawing.

Table 3.4 Details of Drawings

Drawing	Number of Drawings				
	DWG.A	DWG.I	DWG.S	DWG.H	DWG.L
Parent Drawing	1(A)	1(I)	1(S)	1(H)	1(L)
Operation Error Drawing	1(A00)	1(I00)	1(S00)	1(H00)	1(L00)
Child Drawings	Maximum total of 2 drawings	Maximum total of 6 drawings	Maximum total of 14 drawings	Maximum total of 14 drawings	Maximum total of 30 drawings
Grandchild Drawings					

3

3.4.2 Execution Control of Parent Drawings

Each drawing is executed based on its priority level, as shown in the following figure.

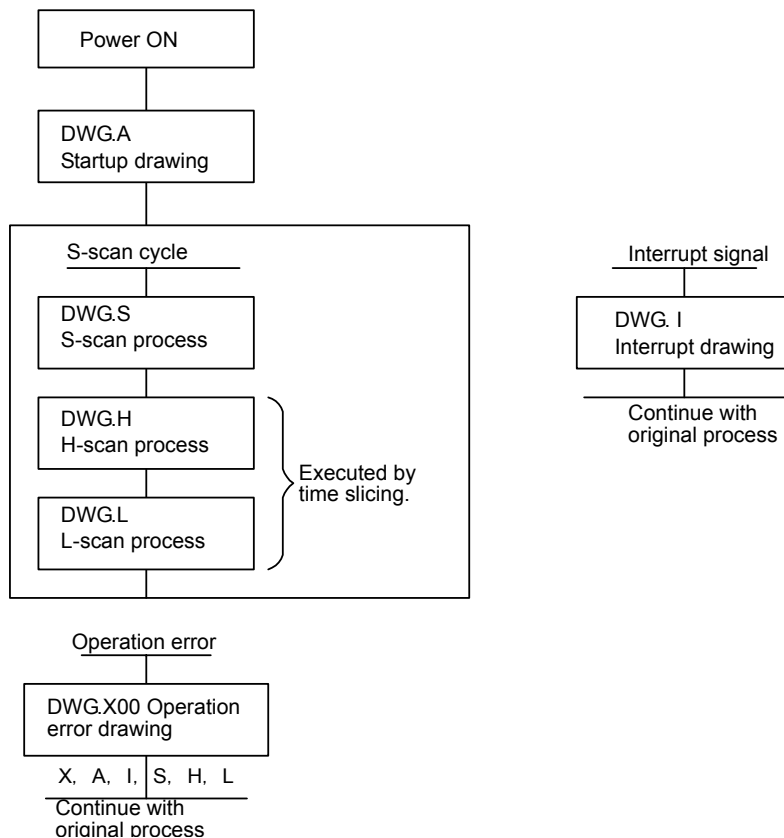

Fig 3.2 Execution Control of Parent Drawings

■ Hierarchical Arrangement of Drawings

Drawings are arranged in the following order: Parent drawing, child drawings, grandchild drawings. A parent drawing cannot call a child drawing of a different type, and a child drawing cannot call a grandchild drawing of a different type. A parent drawing also cannot directly call a grandchild drawing. A child drawing is called from a parent drawing, and a grandchild drawing is called from that child drawing. This is called the hierarchical arrangement of drawings.

■ Execution of Drawings

The user prepares each processing program with the parent drawing, child drawing, grandchild drawing hierarchy, as shown in the following figure.

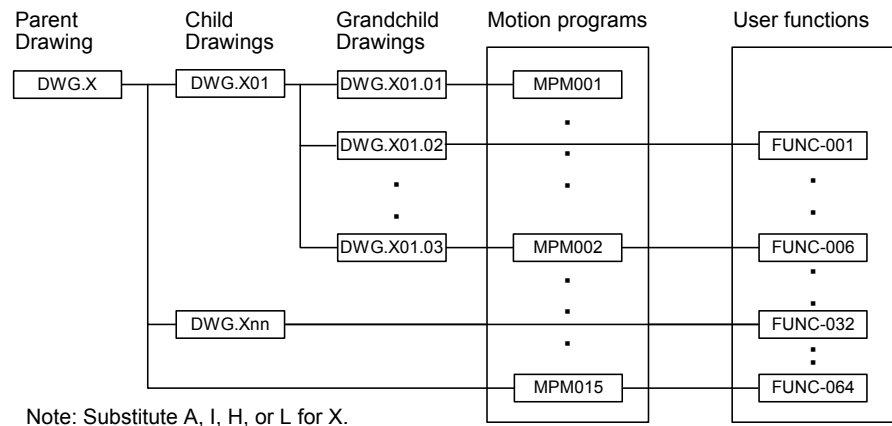

Fig 3.3 Hierarchical Arrangement of Drawings

- Note: 1. A parent drawing is executed automatically by the system, because the execution condition is determined for each one. In other words, a parent drawing is automatically called by the system. See 3.4.1 Drawings (DWGs) the table on Types and Priority Levels of Parent Drawings below. The user can execute any child or grandchild drawing by programming an instruction that calls a drawing (the SEE instruction) in a parent or child drawing.
2. Functions can be called from any drawing. A function can also be called from a function.
 3. If an operation error occurs, the operation error drawing corresponding to the drawing will be called.
 4. Motion programs must be called from H drawings using the MSEE instruction. The MSEE instruction can be used from any H drawing, i.e., from parent, child, or grandchild H drawings.



- A parent drawing cannot call a child drawing of a different type, and a child drawing cannot call a grandchild drawing of a different type.
- A parent drawing cannot directly call a grandchild drawing. A child drawing must be referenced from a parent drawing, and a grandchild drawing must be called from that child drawing.
- A parent drawing is automatically called (and executed) by the system. A child drawing is called from a parent drawing using the SEE instruction. Therefore, user programs containing only child and grandchild drawings cannot be executed.

■ Execution Processing Method of Drawings

Drawings in the hierarchy are executed by the lower-level drawings being called from upper-level drawings. The following figure shows the hierarchical arrangement of drawings, using the example of DWG.A.

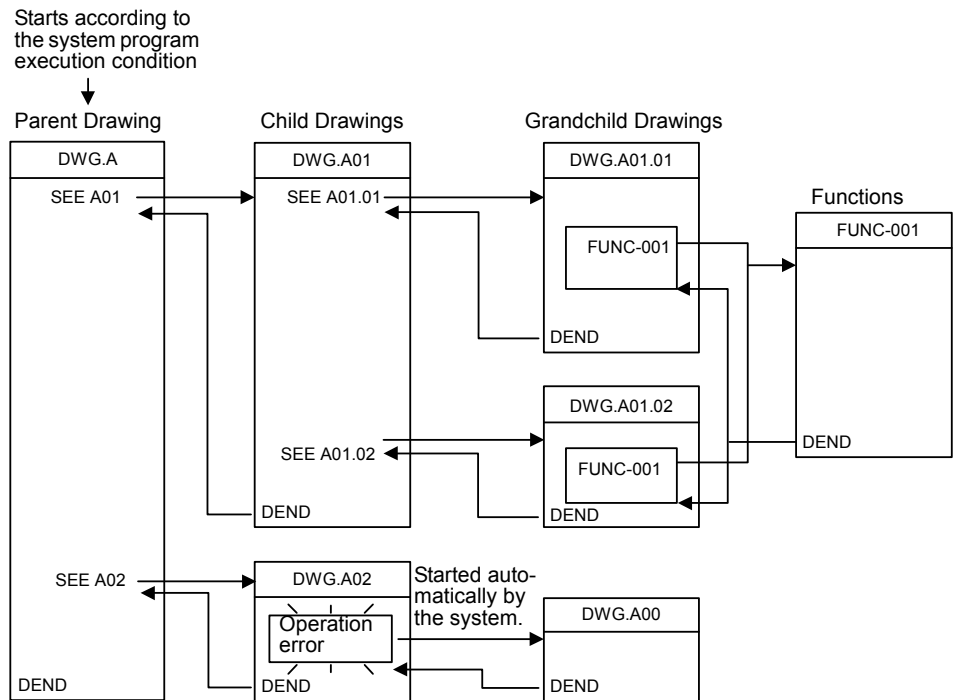

Drawing notation: DWG.X YY .ZZ

- ZZ — Grandchild drawing No. (01 to 99)
- YY — Child drawing No. (01 to 99)
- X — Type of parent drawing (A, I, S, H, L)

:DWG.X 00

- 00 — Operation error drawing (A, I, S, H, L)

3.4.3 Motion Programming

■ Overview

Motion programming is a textual motion programming language. Motion programming can be used to create 32 programs separate from the ladder drawings.

Two types of motion program are provided: Main programs (MPM□□□) that can be called from DWG.H, and subroutines (MPS□□□) that can be called from the main programs.

Table 3.5 Types of Motion Program

Classification	Designation Method	Feature	Number of Programs
Main Programs	MPM□□□ 1 to 32	Can be called from DWG.H drawings.	A total of up to 32 main programs and subroutines can be created.
Subroutines	MPS□□□ 1 to 32	Can be called from the main programs.	

IMPORTANT

- Motion programs must be referenced from an H drawing using the MSEE command.
- Each MPM□□□ and MPS□□□ program number must be unique.

There are two methods of designating a motion program: Direct designation of the program number, and indirect designation of the number of the register in which the program number is stored.

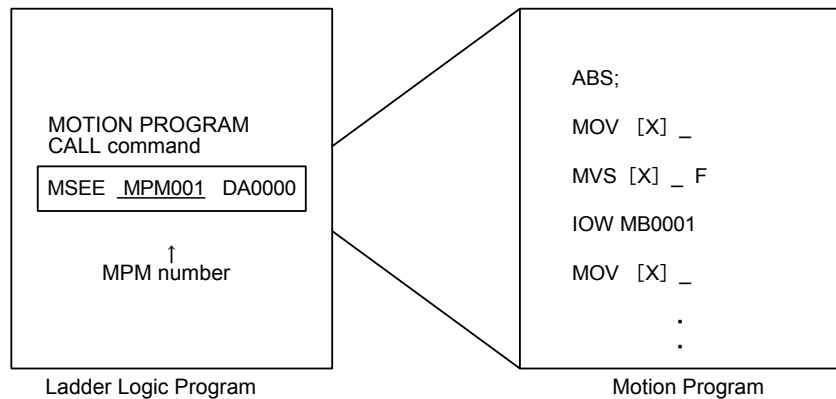

Fig 3.4 Starting a Motion Program by Direct Designation

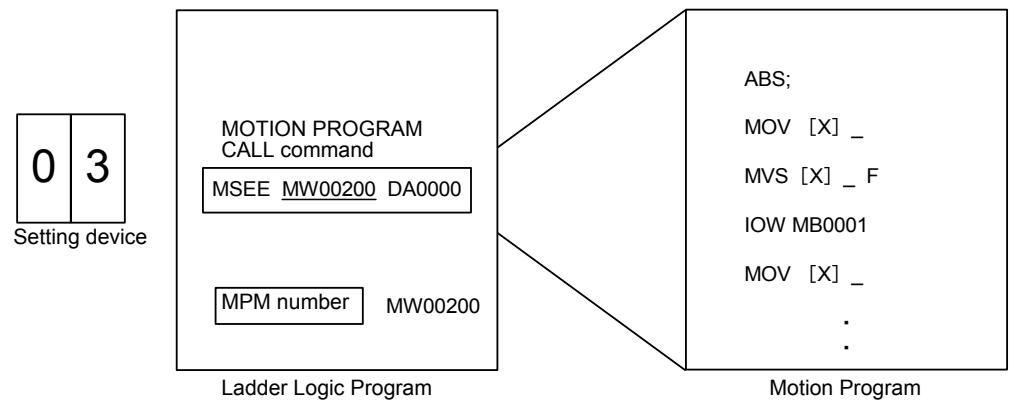
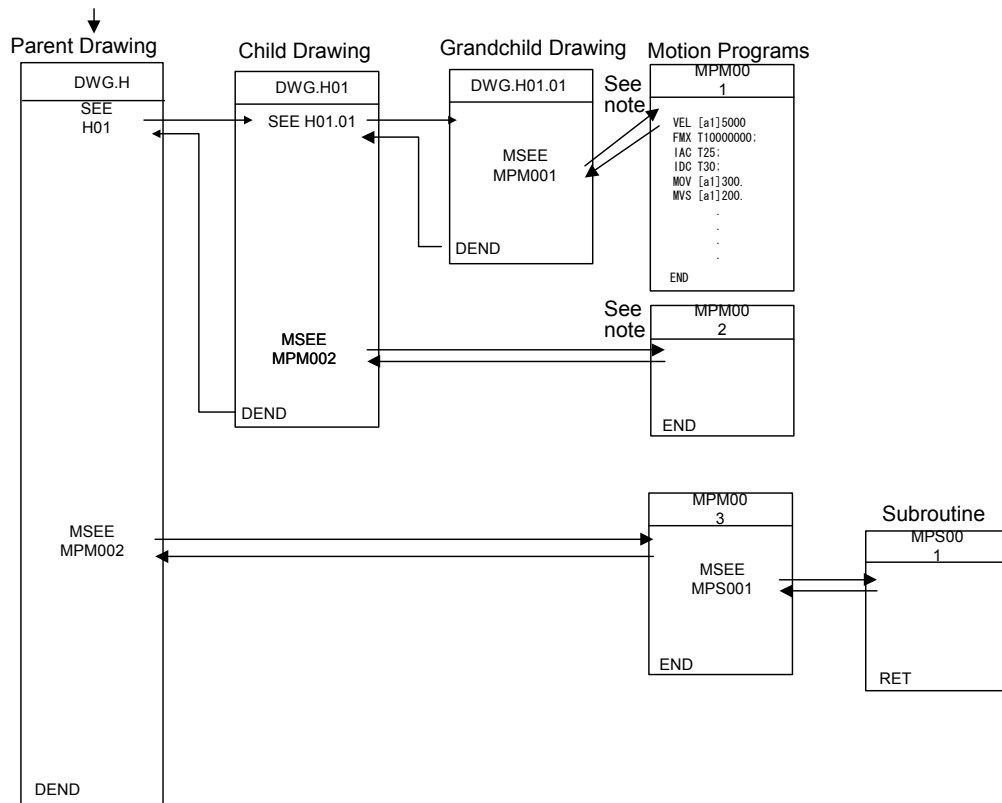

Fig 3.5 Starting a Motion Program by Indirect Designation

■ Motion Program Execution Processing Method

A motion program must be executed from DWG.H using the MSEE instruction. Motion programs can be executed from any H drawing, i.e., from parent, child, and grandchild H drawings.

The system program is started according to the execution condition.



In each high-speed scanning cycle, the ladder logic instructions for H drawings are executed in the following hierarchical order: Parent drawing - child drawing - grandchild drawing.

Motion programs are called in the scanning cycle, but as with ladder logic programs, all programs cannot be executed in one scan. Motion programs are executed and controlled by special system motion management functions.

Motion programs are called in the scanning cycle, but they are not executed only in this cycle. The control signals set on the Group Definition Screen must be input. (See the next section.)



The following restrictions apply to calling motion programs. Call motion program with care.

- More than one motion program with the same number cannot be called using the MSEE instruction.
- Subroutines (MPSxxx) cannot be called from the ladder logic program MSEE instruction. They can be called only from within motion programs (MPMxxx and MPSxxx).
- The same subroutine cannot be called from two different locations at the same time.

■ Executing Motion Programs

To execute a motion program called from a DWG.H drawing by the MSEE instruction, program control signals (such as program operation start requests and program stop requests) must be input. Operations are enabled by inputting the external control signals defined on the Group Definition Screen as the program control signals.

The signals used to control motion programs are shown in the following table.

Bit	Signal Name	Signal Type
b0:	Program operation start request	Differential input
b1:	Program pause request	NO contact (Normally open contact)
b2:	Program stop request	NO contact
b3:	Program debugging mode selection	NO contact
b4:	Program debugging start request	Differential input
b5:	Alarm reset request	NO contact
b8:	Skip 1 information	NO contact
b9:	Skip 2 information	NO contact

The motion program operation, stop, pause, and so on, can be controlled by using a ladder logic program to input these signals into the one register higher than the work register specified with the MSEE instruction.

For the ladder logic program inputs, make sure the signals are in accordance with the signal type.

IMPORTANT

When the start signal is input using an NO contact, the program is completed and then restarted. The program will not be executed if the start signal has been turned ON when the power is turned ON.

The following illustration shows the method for executing a motion program.

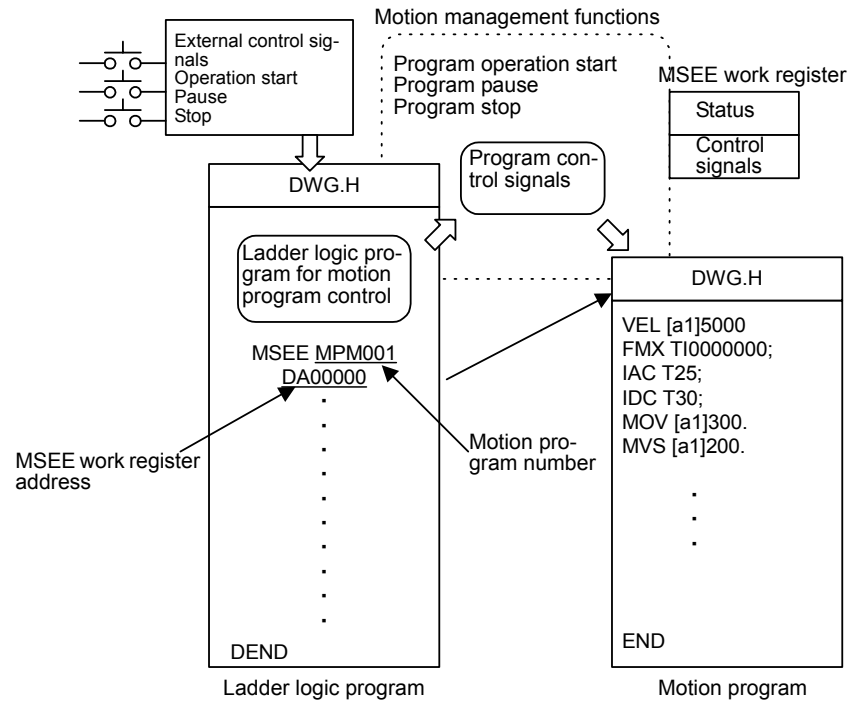

■ Motion Program Status Flags

The first word of a MSEE work register consists of motion program status flags, which indicate the status of motion program execution. The following table shows the status flags.

Bit	Status
b0:	Program is running.
b1:	Program is temporarily stopped.
b2:	(Reserved by the system)
b3:	(Reserved by the system)
b4:	Program is being debugged.
b8:	Program alarm has been generated.
bB:	Debugging mode (EWS debugging)
bE:	Main program duplication error
bF:	Main program number limit error

■ Example of a Ladder Logic Program for Motion Program Control

The minimum ladder logic program required to control a motion program is shown in the following illustration.

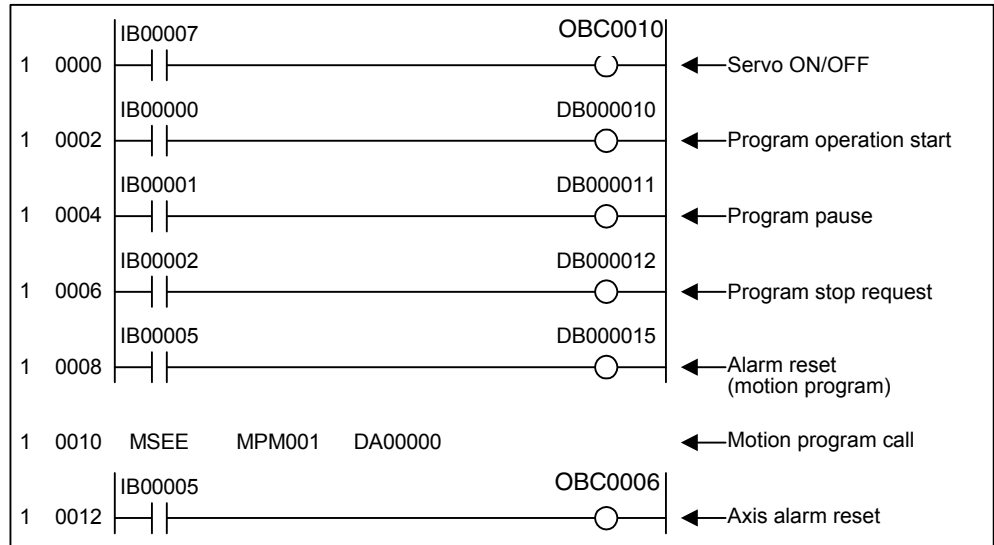

The contents of this ladder logic program are shown in the following table.

Step Number	Program Content
0	Turns ON or OFF the servo power supply.
2 to 8	The signals connected to the MP940 external input signals are stored as the motion program control signals. IW0000 (external input signals) → DW00001 (second word of MSEE work registers) <ul style="list-style-type: none"> • Program operation start • Program pause • Program stop request • Alarm reset
10	Calls motion program MPM001 MSEE <u>MPM001</u> <u>DA00000</u> 1 2 1. Motion program number 2. MSEE work register address
12	Resets the alarm (bit 6 of OWC000) using the alarm reset signal (IB00005), and clears the alarm for each axis.

When the external input signals (IB00000 to IB00005) connected to the MP940 are input to DW00001 (second word of MSEE work registers) as motion program control signals using the ladder logic program shown above, motion program operations such as run, stop and pause can be performed by the system motion management functions.

◀EXAMPLE▶

The following table shows an example of external input signals required to create the minimum ladder logic program for running motion programs on the MP940.

Table 3.6 External Input Signals and Motion Program Control Signals

External Signal Address	External Signal Name	BIT	Motion Program Control Signal
IB00000:	Program operation start	B0:	Program operation start request
IB00001:	Program pause	B1:	Program pause request
IB00002:	Program stop	B2:	Program stop request
IB00003:	Program debugging mode	B3:	Program debugging mode selection
IB00004:	Program debugging start	B4:	Program debugging start request
IB00005:	Alarm reset	B5:	Alarm reset request

■ Automatic Generation of Motion Management Ladder Logic Programs

An automatic generation function for the ladder logic programs used to control motion programs is provided with the MP940. This function enables JOG operations and program operations to be performed without the need for special ladder logic programs to be created, and greatly reduces the system startup time.

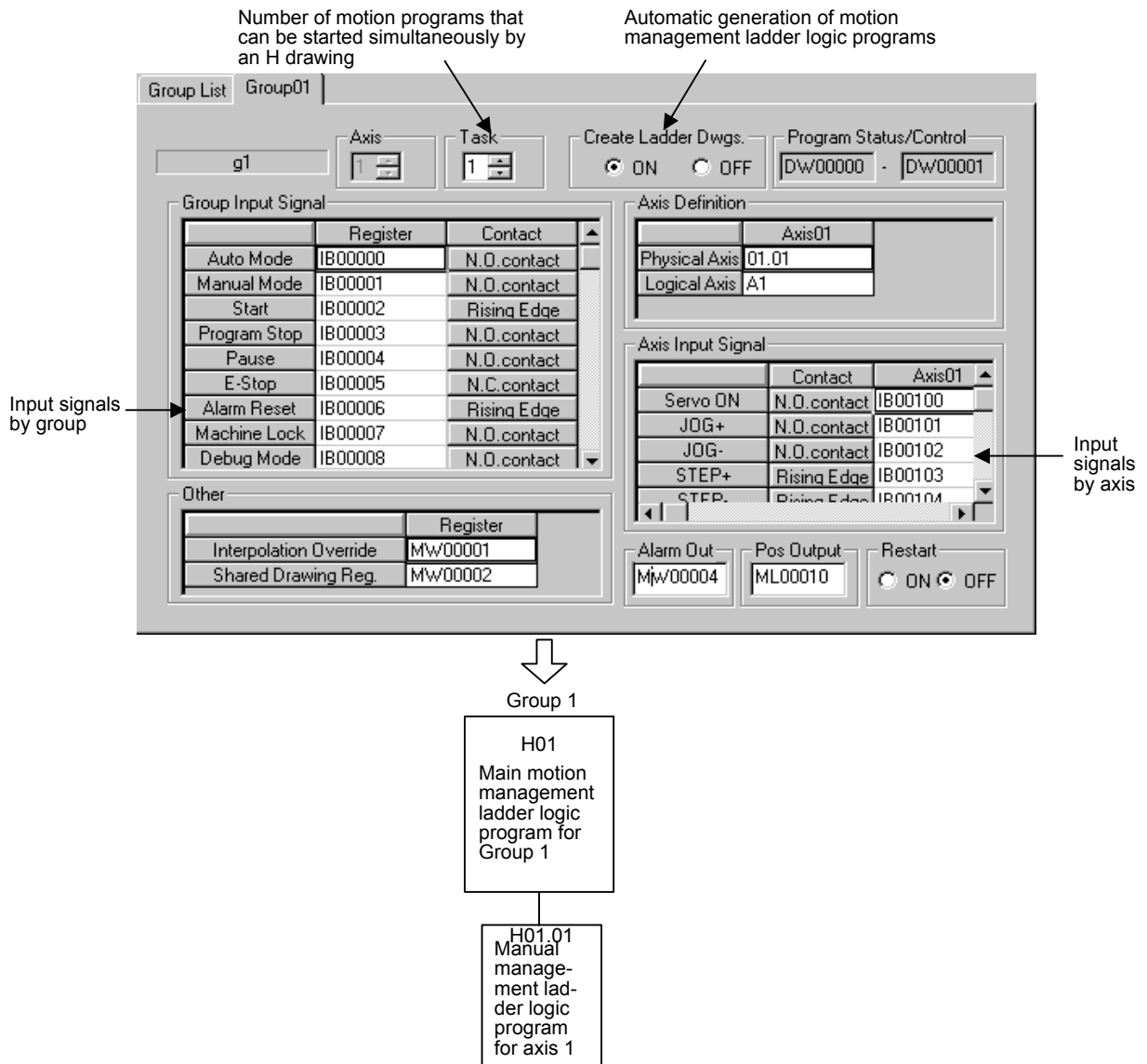

The ladder logic programs that are generated for motion program control are created automatically using the external input signals that are allocated on the Group Definition Screen. These ladder logic programs can also be used as is. It is recommended, however, that they be used as templates to be optimized (changed) to suit individual system requirement.

3.5 Functions

This section explains the methods of using and the advantages of the MP940 functions.

Functions are executed by being called from a parent, child, or grandchild drawing using the FSTART instruction.

Unlike child and grandchild drawings, functions can be called from any drawing. The same function can also be called simultaneously from drawings of different types and different hierarchies. Moreover, a function can also be called from another function that was previously created.

The following advantages can be obtained by using functions:

- Programs can be easily divided into parts.
- Programs can be easily prepared and maintained.

Functions are divided into standard system functions, which are provided by the system, and user functions, which are defined by the user.

3.5.1 Standard System Functions

Nine functions, including the transfer function, are provided by the system as standard functions. See the following table for details. The user cannot change the standard system functions.

Table 3.7 List of Standard System Functions

Type	Name	Symbol	Description
System Functions	Counter	COUNTER	Up/down counter
	First-in first-out	FINFOUT	First-in or first-out stack
	Trace function	TRACE	Data trace execution control
	Data trace read	DTRC-RD	Data readout from data trace memory to user memory
	Send message function	MSG-SND	Sending a message from a Communications Module
	Receive message function	MSG-RCV	Receiving a message from a Communications Module

3.5.2 Creating User Functions

The body of the function (program) and the function definitions can be set by the user. The maximum number of user functions is 32 per drawing.

The methods for creating user functions is explained according to the following procedure.

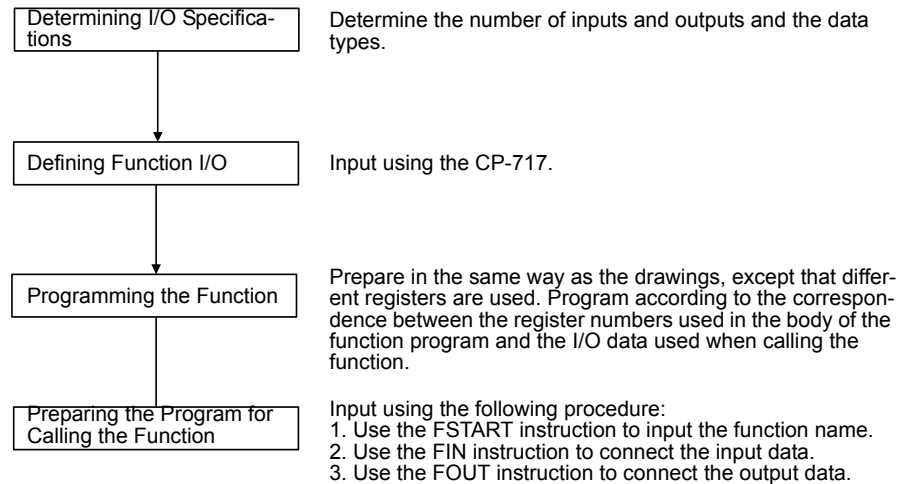

3



- For details on CP-717 operations, refer to *MP9□□ Machine Controller User's Manual Programming Panel Software* (SIEZ-C887-2.3 (for simple operation) (To be prepared), SIEZ-C887-2.4 (for standard operation) (To be prepared)).
- For details on using instructions such as FSTART, refer to *MP9□□ Machine Controller User's Manual Programming* (SIEZ-C887-1.2).

3.5.3 Determining the I/O Specifications

When a user function is created, the function capabilities, the number of inputs and outputs required to satisfy the function, and other specifications must first be determined. Determine the four types of specification shown in the following table.

Table 3.8 Overview of Function Definition Values

Specification to be Determined	Overview
Function Name	Up to eight characters can be input.
Number of Inputs	The number of arguments input into a function. Up to 16 can be input. Up to 17 arguments are possible if the address input is also counted.
Number of Address Inputs*	The designated number of addresses required by the function. A maximum of one value can be input.
Number of Outputs	The number of outputs from the function. Up to 16 can be input.

* Indicates the number of pointers to be provided for the external function registers used by the function.

3.5.4 Defining Function I/O

The function name and other specifications determined in the previous step are defined using the CP-717. For details on operation methods, refer to the *MP9 Machine Controller User's Manuals Programming Panel Software* (SIEZ-C887-2.3 (for simple operation) (To be prepared), SIEZ-C887-2.4 (for standard operation) (To be prepared)).

◀EXAMPLE▶

The following figure shows the graphic representation of a function when the following function is defined: Function name = TEST, number of inputs = 4, number of address inputs = 1, and number of outputs = 4.

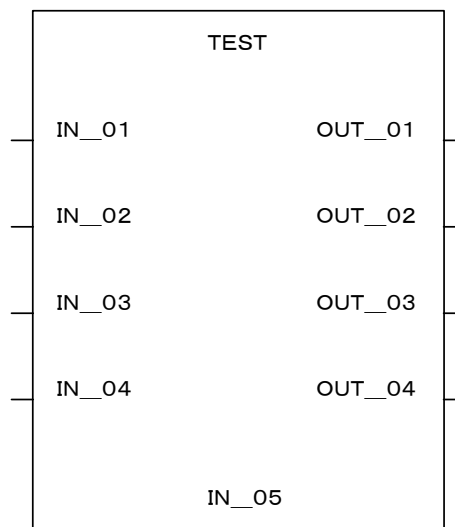

Fig 3.6 Graphic Representation of a Function 1 (Example)

- Note: 1. After creating the graphic representation of the function, define the data types of the function inputs, outputs, and address inputs.
2. Three data types can be defined: Bit, integer, and double integer.
 3. When the data types are defined, the system automatically allocates inputs to the X registers, outputs to the Y registers, and address inputs to the A registers.

The following figure shows an example of the I/O definitions of a function.

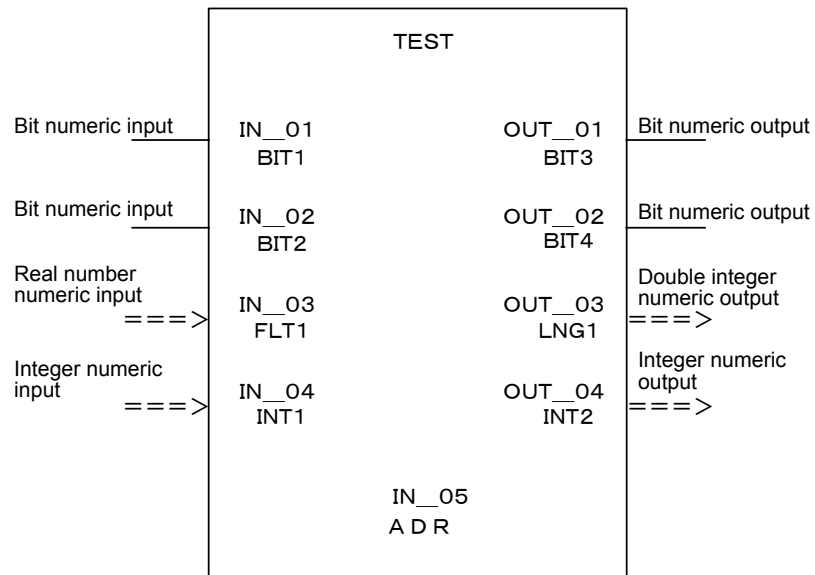

Fig 3.7 Graphic Representation of a Function 2 (Example)

I/O signal addresses are automatically allocated from the highest signal on the graphic representation. For the example given in the figure shown above, the allocation of each I/O register will be as shown in the following table.

Table 3.9 Allocation of I/O Registers

Name	Data Type	I/O Register
IN __ 01 (BIT1)	Bit	XB000000
IN __ 02 (BIT2)	Bit	XB000001
IN __ 03 (FLT1)	Real number	XF00001
IN __ 04 (INT1)	Integer	XW00003
IN __ 05 (ADR)	Address input	AW00000
OUT __ 01 (BIT3)	Bit	YB000000
OUT __ 02 (BIT4)	Bit	YB000001
OUT __ 03 (LNG1)	Double integer	YL00001
OUT __ 04 (INT2)	Integer	YW00003

Note: XW00000 and YW00000 of the X and Y registers are used for bit data.

The function I/O registers shown in the above figure are allocated automatically. The external framework of the function is completed at this stage.

3.5.5 Creating the Body of the Function

The body of the function is created in the same way as the drawings except that the types of register used are different. For details on the registers, see 3.6.3 *Types of Register*.

3.5.6 Creating the Program that Calls the Function

The user function is completed when the graphic representation and body program of the function have been created. As with the standard system functions, user functions can be called from any parent, child, or grandchild drawing or any other user function. Functions can be called from a drawing or from within the program of another user function by using the following procedure. For details on the operation methods, refer to the *MP9 Machine Controller User's Manual Ladder Programming (SIEZ-C887-1.2)*.

1. Input the function name using the FSTART instruction.

Example: Input FSTART, Enter Key, TEST, Enter Key.

The previously defined graphic representation of the function will be displayed.

2. Use the FIN instruction to create the input data program.

Provide input data for the function inputs and address inputs.

3. Use the FOUT instruction to create the output data program.

Example: I/O data is provided for the graphic representation as shown in the following illustration.

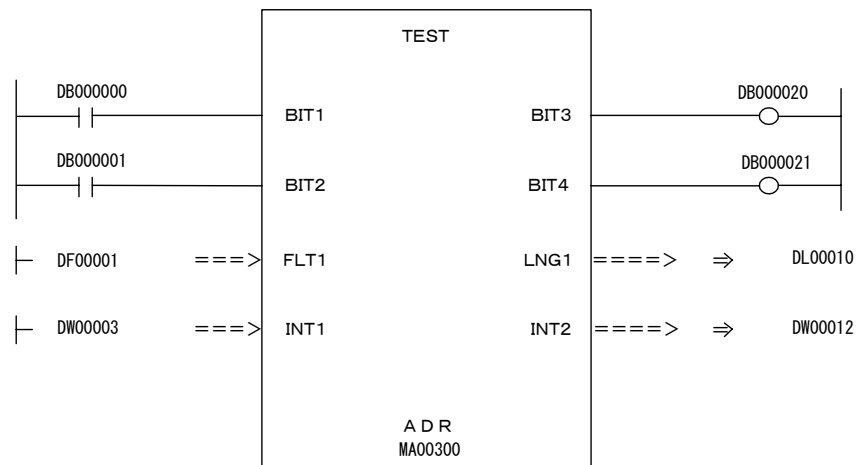

Fig 3.8 Graphic Representation for which Input Data is Provided (Example)

Table 3.10 Relationship Between I/O Data and Internal Function Registers

Name	I/O Data	Internal Function Register
BIT1	DB000000 →	XB000000
BIT2	DB000001 →	XB000001
FLT1	DF00001 →	XF00001
INT1	DW00003 →	XW00003
ADR	MA00300 ↔	AW00000
BIT3	← OB00020	YB000000
BIT4	← OB00021	YB000001
LNG1	← DL00010	YL00001
INT2	← DW0012	YW00003

In the table, address input register AW00000 is allocated to MA00300. That is, registers AW00000, AW00001, and so on, used inside the TEST function correspond to external registers MA00300, MA00301, and so on. Therefore, if a given value in AW00000 is stored inside the function, this value will be stored in MA00300.

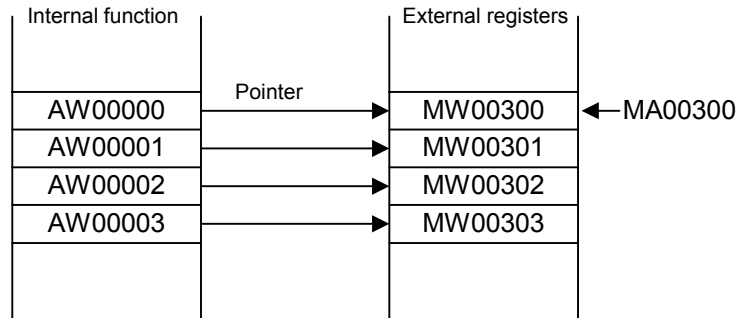

Fig 3.9 Pointer Designation for Address Input Registers

4. Create a motion program that calls the function.

User functions can also be called from motion programs.

◀ **EXAMPLE** ▶

The user functions shown in the Relationship Between I/O Data and Internal Function Registers Table would be called from a motion program using the following coding:

```
UFC TEST DB000000 DB000001 DF00001 DW00003,MA00300,
      DB000020 DB000021 DL00010 DW00012;
```



Conditions for referencing a user function from a motion program:

The first item of output data must be bit data.

This output will be the completion signal for moving to the next motion command.

```
UFC DB000000 ..., MA00300, DB000020 ...;           ↓ Condition
MVS [X]100. F10000;                                DB000020==ON
.
.
.
```

3.6 Registers

This section explains the types of register used by MP940 user programs and how these registers are used.

3.6.1 Register Designation Methods

Registers can be designated by direct designation of the register number or by symbolic designation. These two types of register designation can be used together in the same user program. When symbolic designation is used, the correspondence between the symbols and the register numbers is defined in the symbol table that is described later.

The following table shows the register designation methods.

Table 3.11 Register Designation Methods

Designation Type	Description
Direct Register Number Designation	Bit registers: MB00100AX Integer registers: MW00100X Double integer registers: ML00100X Real # registers: MF00100X Address registers: MA00100X X: For subscripts, add the subscript i or j after the register number.
Symbol Designation	Bit registers: RESET1-A.X Integer registers: STIME-H.X Double integer registers: POS-REF.X Real # registers: IN-DEF.X Address registers: <u>PID-DATA</u> .X ↓ Address registers are designated using up to 8 alphanumeric characters. X: For subscripts, add a period (.) and then the subscript i or j after the symbol.

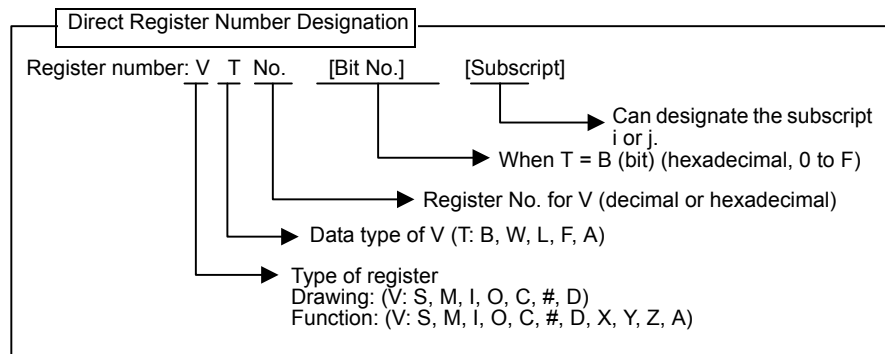

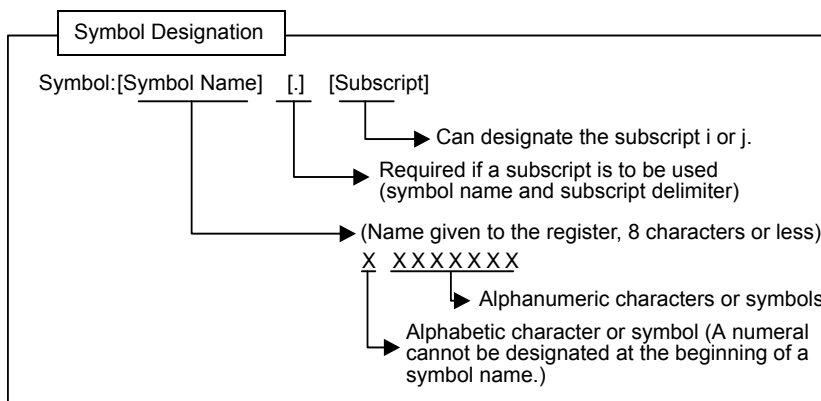

3.6.2 Data Types

There are five data types: Bit, integer, double integer, real number, and address. Use them as required. Address data is used only for pointer designations inside functions. For details, refer to the *MP9□□ Machine Controller User's Manual Ladder Programming* (SIEZ-C887-1.2). The following table shows the data types and their numeric ranges.

3

Table 3.12 Data Types and Numeric Range

Type	Data Type	Numeric Range	Remarks
B	Bit	ON, OFF	Used in relay circuits.
W	Integer	-32768 to +32767 (8000H) (7FFFH)	Used in numeric operations. The values in parentheses () are used in logic operations.
L	Double integer	-2147483648 to +2147483647 (80000000H) (7FFFFFFFH)	Used in numeric operations. The values in parentheses () are used in logic operations.
F	Real number	±(1.175E-38 to 3.402E+38), 0	Used in numeric operations.
A	Address	0 to 32767	Used only for pointer designations.

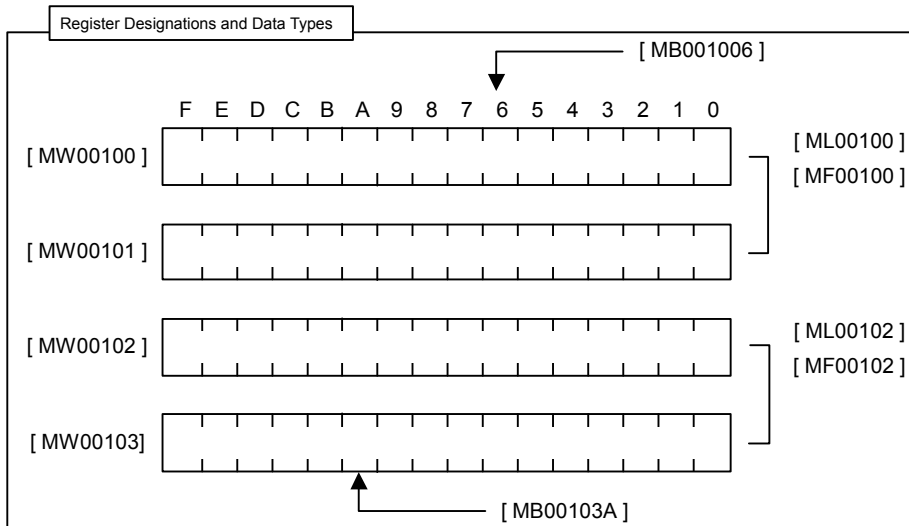

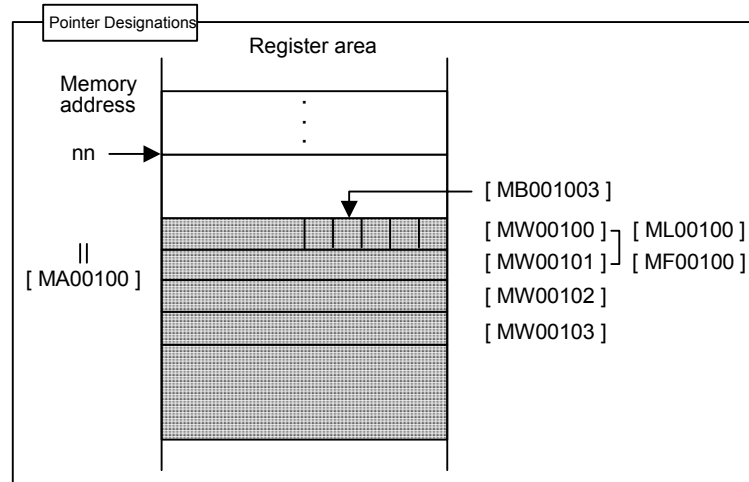

Examples of Use by Data Type

Bits

Bits are used for relay circuit ON/OFF or for logic operations.

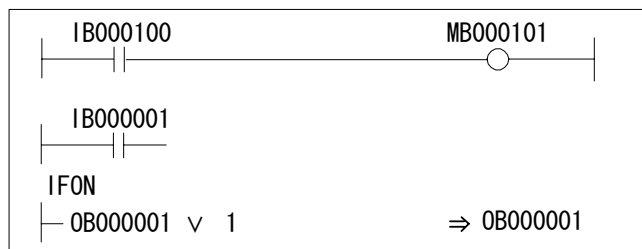

- Motion Program Example

◀EXAMPLE▶

```
MB000101=IB000100;
IF IB000001==1;
DB000001=DB000001 | 1
```

Words

Words are used for numeric operations and logic operations.



- Motion Program Example

◀EXAMPLE▶

```
MW00101=MW00100 | 00FFH;
MW00103=MW00102+12345;
MW00105=MW00104;
```

Double Integers

Double integers are used for numeric operations and logic operations.

— ML00100 + ML00102	⇒ ML00104
— ML00106 × ML00108 ÷ 18000	⇒ ML00110
— ML00112 BIN	⇒ ML00114

- Motion Program Example

◀EXAMPLE▶

```
ML00104=ML00100+ML00102;
ML00110=ML00106*ML00108/18000;
ML00114=BIN (ML00112) ;
```

Real Numbers

Real numbers are used for floating-point numeric operations.

— 1. 23456	⇒ DF00100 (1. 23456)
— DF00102 SIN (30. 0)	⇒ DF00104 (0. 5)
— DF00200 TAN (45. 0)	⇒ DF00202 (1. 0)

- Motion Program Example

◀EXAMPLE▶

```
DF00100=1.23456;
DF00104=SIN (DF00102) ;
DF00202=TAN (DF00200) ;
```

Addresses

Addresses are used only for pointer designations.

MF00200 to MF00228 are used as the parameter table in the following example

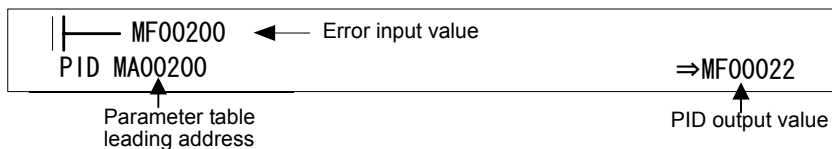

MF00200 to MF00204 are used as the parameter table in the following example.

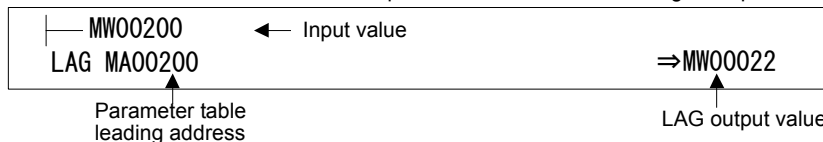

3.6.3 Types of Register

■ Registers in Drawings

The seven types of register shown in the following table can be used in all drawings and motion programs.

Table 3.13 Types of Drawing Register

Type	Name	Designation Method	Range	Description	Characteristic
S	System registers	SB, SW, SL, SFnnnnn (SAnnnnn)	SW00000 to SW01023	System registers provided by the system. Register number nnnnn is expressed as a decimal number. When the system is started, SW00000 to SW00049 are cleared to 0.	Common to all drawings
M	Data registers	MB, MW, ML, MFnnnnn (MAnnnnn)	MW00000 to MW32767	Data registers are shared by all drawings. Used as interfaces between drawings. Register number nnnnn is expressed as a decimal number.	
I	Input registers	IB, IW, IL, IFhhhh (IAhhhh)	IW0000 to IW07FF	Registers used for input data. Register number hhhh is expressed as a hexadecimal number.	
O	Output registers	OB, OW, OL, OFhhhh (OAhhhh)	OW0000 to OW07FF	Registers used for output data. Register number hhhh is expressed as a hexadecimal number.	
C	Constant registers	CB, CW, CL, CFnnnnn (CAnnnnn)	CW00000 to CW32767	Constant registers can be called only in the program. Register number nnnnn is expressed as a decimal number.	
#	# registers	#B, #W, #L, #Fnnnnn (Annnnn)	#W00000 to #W16383	# registers can be called only in the program and can be used only in the corresponding drawing. The actual range used is specified by the user on the CP-717. Register number nnnnn is expressed as a decimal number.	Unique to each drawing
D	D registers	DB, DW, DL, DFnnnnn (DAnnnnn)	DW00000 to DW16383	D registers are unique to each drawing and can be used only in the corresponding drawing. The actual range used is specified by the user on the CP-717. Register number nnnnn is expressed as a decimal number.	



- The # registers cannot be used in motion programs.
- The following registers are saved in flash memory.
 - M registers
 - C registers
 - # registers (Saved with the user program.)
 - D registers (Saved with the user program.)

■ Registers in Functions

The 11 types of register shown in the following table can be used in functions.

Table 3.14 Types of Function Register

Type	Name	Designation Method	Range	Description	Characteristic
X	Function input registers	XB, XW, XL, XFnnnnn	XW00000 to XW00016	Input to a function. Bit input: XB000000 to XB00000F Integer input: XW00001 to XW00016 Double integer input: XL00001 to XL00015 Register number nnnnn is expressed as a decimal number.	Unique to each function
Y	Function output registers	YB, YW, YL, YFnnnnn	YW00000 to YW00016	Output from a function. Bit input: YB000000 to YB00000F Integer input: YW00001 to YW00016 Double integer input: YL00001 to YL00015 Register number nnnnn is expressed as a decimal number.	
Z	Internal function registers	ZB, ZW, ZL, ZFnnnnn	ZW0000 to ZW00063	Internal registers unique to each function. Can be used in the function for internal processes. Register number nnnnn is expressed as a decimal number.	
A	External function registers	AB, AW, AL, AFhhhh	AW0000 to AW32767	External registers that use the address input value as the base address. For linking with S, M, I, O, #, and DANnnnn registers. Register number nnnnn is expressed as a decimal number.	
#	# registers	#B, #W, #L, #Fnnnnn (Annnnn)	#W00000 to #W16383	Registers that can only be called by a function. Can be used only by the corresponding function. The actual range used is specified by the user on the CP-717. Register number nnnnn is expressed as a decimal number.	
D	D registers	DB, DW, DL, DFnnnnn (DAnnnnn)	DW00000 to DW16383	Internal registers unique to each function. Can be used only by the corresponding function. The actual range used is specified by the user on the CP-717. Register number nnnnn is expressed as a decimal number.	

Type	Name	Designation Method	Range	Description	Characteristic
S	System registers	SB, SW, SL, SFnnnnn (SAnnnnn)		Same as the registers for drawings. These registers can be called from any drawings or function. Use them carefully when the same function is referenced from drawings with different priority levels.	
M	Data registers	MB, MW, ML, MFnnnnn (MAnnnnn)			
I	Input registers	IB, IW, IL, IFhhhh (IAhhhh)			
O	Output registers	OB, OW, OL, OFhhhh (OAhhhh)			
C	Constant registers	CB, CW, CL, CFnnnnn (CAhhhh)			

Note: SA, MA, IA, OA, DA, #A, and CA can be used within functions.

3.6.4 Using Subscripts I and J

Two types of register, I and J, are used exclusively for modifying relay numbers and register numbers. I and J have exactly the same function.

An example of each register data type is explained below.

■ Subscripts Attached to Bit Data

When subscript i or j is attached to bit data, the value of I or J is added to the relay number. For example, if I = 2, MB000000i will be the same as MB000002. If J = 27, MB000000j will be the same as MB00001B.

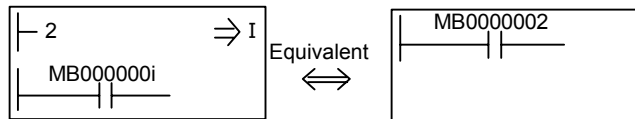

■ Subscripts Attached to Integer Data

When a subscript is attached to integer data, the value of I or J is added to the register number. For example, if I = 3, MW00010i will be the same as MW00013. If J = 30, MW00001j will be the same as MW00031.

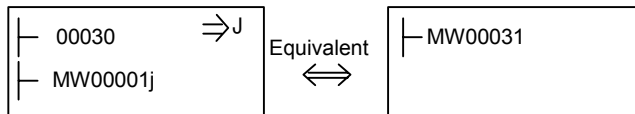

■ Subscripts Attached to Double Integer Data

When a subscript is attached to double integer data, the value of I or J is added to the register number. For example, if I = 1, ML00000i will be the same as ML00001. ML00000j when J = 0, and ML00000j when J = 1 will be as follows:

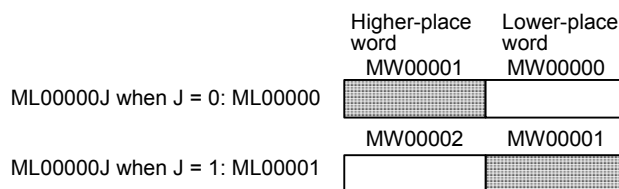

■ Subscripts Attached to Real Number Data

When a subscript is attached to real number data, the value of I or J is added to the register number. For example, if I = 1, MF00000i will be the same as MF00001. MF00000j when J = 0, and MF00000j when J = 1 will be as follows:

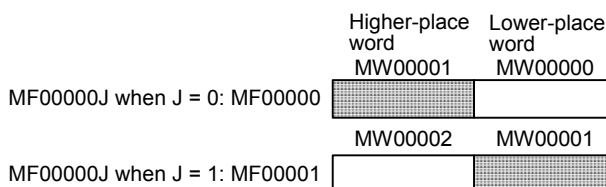

Programming Example Using Subscripts

The programming code shown in the following figure sets the sum of 100 registers from MW00100 to MW00199 in MW00200 using subscript J.

```

┌ 00000           ⇒ MW00200
└──────────
FOR J = 00000 to 00099 by 00001
┌ MW00200 + MW00100j   ⇒ MW00200
└──────────
FEND

```

Fig 3.10 Programming Example Using a Subscript



Subscripts I and J cannot be used in motion programs.

- Subscripts I and J must be initialized.
- Subscripts I and J are treated as unsigned values. Do not use numbers smaller than 0.

3.6.5 I/O and Registers in Functions

The following table shows the I/O and registers referenced in functions.

Table 3.15 Correspondence Between I/O and Registers in Functions

Function I/O	Function Register
Bit inputs	The bit numbers increase continuously from XB000000 in order of the bit inputs: XB000000, XB000001, XB000002,, XB00000F
Integer, double integer, and real number inputs	The register numbers increase continuously from XW, XL, and XF00001 in order of the integer, double integer, and real number inputs: (XW00001, XW00002, XW00003,, XW00016) (XL00001, XL00003, XL00005,, XL00015) (XF00001, XF00003, XF00005,, XF00015)
Address inputs	The address input values correspond to register numbers 0 of the external register: Input value = MA00100: MW00100 = AW00000, MW00101 = AW00001...
Bit outputs	The bit number increases continuously from YB000000 in order of bit outputs: (YB000000, YB000001, YB000002,, YB00000F)
Integer, double integer, and real number outputs	The register numbers increase continuously from YW, YL, and YF00001 in order of the integer, double integer, and real number outputs. (YW00001, YW00002, YW00003,, YW00016) (YL00001, YL00003, YL00005,, YL00015) (YF00001, YF00003, YF00005,, YF00015)

3.6.6 Register Ranges in Programs

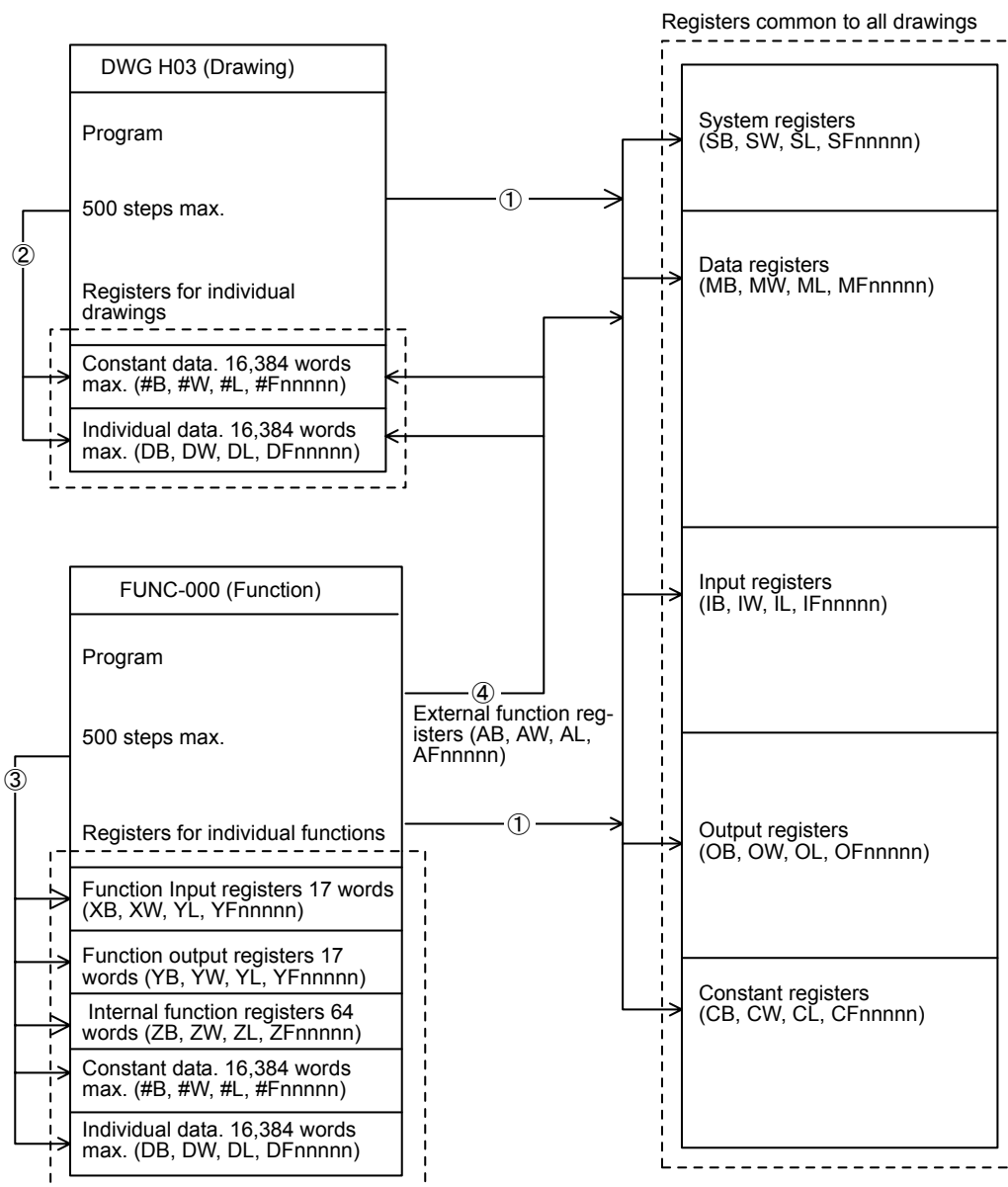

1. Registers that are common to all drawings can be called from any drawing or function.
2. Registers that are unique to each drawing can be called only from within that drawing.
3. Registers that are unique to each function can be called only from within that function.
4. Registers that are common to all drawings and registers that are unique to each drawing can be called from a function using the external function registers.

3.7 Managing Symbols

3.7.1 Symbols in Drawings

The symbols used in drawings are all managed with a symbol table, such as the one shown in the following table. For details, refer to the *MP9□□ Machine Controller User's Manual Ladder Programming* (SIEZ-C887-1.2).

Table 3.16 Drawing Symbol Table (Example)

No.	Register No.	Symbol	Size *	Remarks
0	IB0000	STARTPBL	1	The register number is expressed as a hexadecimal number.
1	OB0000	STARTCOM	1	The register number is expressed as a hexadecimal number.
2	MW00000	SPDMAS	1	
3	MB000010	WORK – DB	16	
4	MW00010	PIDDATA	10	
5	MW00020	LAUIN	1	
6	MW00021	LAUOUT	1	
:				
:				
N				

* If a program is written using data configurations such as arrays or indexed data, define the size to be used in the data configuration. For example, if the data is referenced as PIDDATA_I and i varies in a range of 0 to 9, define the size as 10.

3.7.2 Symbols in Functions

All symbols used in the functions are managed with the function symbol table shown below. For details, refer to the *MP9□□ Machine Controller User's Manual Ladder Programming* (SIEZ-C887-1.2).

Table 3.17 Function Symbol Table

No.	Register No.	Symbol	Size *	Remarks
0	XB000000		1	
1	XW00001		1	
2	AW00001		1	
3	AB00000F		1	
4	YB000000		1	
5	YW00001		1	
6	ZB000000		4	
7	ZW00001		1	
8	ZW00002		1	
:				
:				
N				

- * If a program is prepared using data configurations such as arrays or indexed data, define the size to be used in the data configuration. For example, if the data is referenced as PIDDATA_I and i varies in a range of 0 to 9, define the size as 10.

3.7.3 Upward Linking of Symbols

The following table shows the symbols that can be linked and the symbols tables that are subject to linking. For details on the upward linking of symbols, refer to the *MP9□□ Machine Controller User's Manual Ladder Programming* (SIEZ-C887-1.2) and the *MP9□□ Machine Controller User's Manual Programming Panel Software* (SIEZ-C887-2.3 (for simple operation) (To be prepared), SIEZ-C887-2.4 (for standard operation) (To be prepared)).

Table 3.18 Linkable Symbols and Symbol Table for Linking

Symbol Table	Parent Drawing	Child Drawing	Grandchild Drawing
Parent Drawing Symbols	No	No	No
Child Drawing Symbols	Yes	No	No
Grandchild Drawing Symbols	Yes	Yes	No
Symbols Within A Function	No	No	No

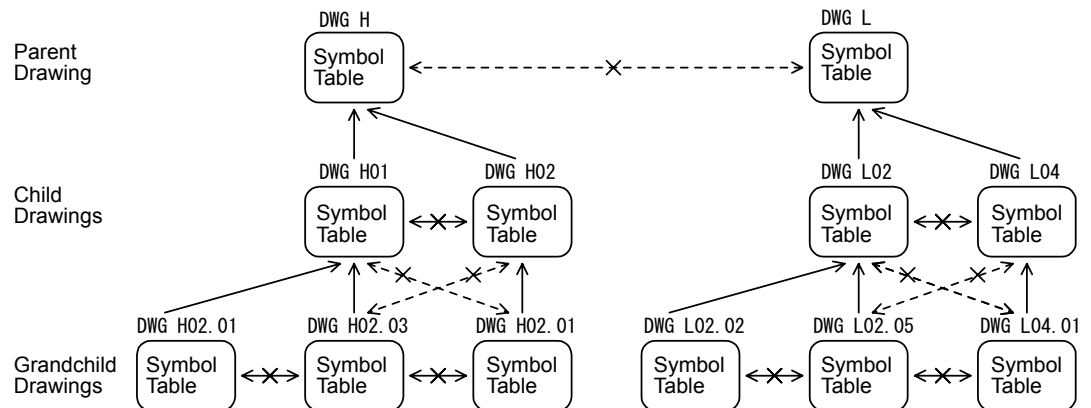

3.7.4 Automatic Register Number Allocation

The following table shows the register numbers for which automatic allocation is possible and those for which it is not possible. For details on the automatic allocation of register numbers, refer to the *MP9□□ Machine Controller User's Manual Ladder Programming* (SIEZ-C887-1.2) and the *MP9□□ Machine Controller User's Manual Programming Panel Software* (SIEZ-C887-2.3 (for simple operation) (To be prepared), SIEZ-C887-2.4 (for standard operation) (To be prepared)).

Table 3.19 Automatic Allocation of Register Numbers

Drawing Symbol Table		Automatic Number Allocation	Function Symbol Table		Automatic Number Allocation
		CP-717			CP-717
System registers	S	Yes	System registers	S	Yes
Input registers	I	Yes	Input registers	I	Yes
Output registers	O	Yes	Output registers	O	Yes
Data registers	M	Yes	Data registers	M	Yes
# registers	#	Yes	# registers	#	Yes
C registers	C	Yes	C registers	C	Yes
D registers	D	Yes	D registers	D	Yes
			Function input registers	X	No
			Function output registers	Y	No
			Internal function registers	Z	Yes
			External function registers	A	No

Note: Yes: Automatic number allocation possible

No: Automatic number allocation not possible

4 MP940 Functions

This chapter explains the various MP940 functions.

4.1 MP940 Function Configuration	4-3
4.1.1 Overview	4-3
4.1.2 Simulated MP940 Building Block Configuration	4-5
4.2 Serial Communications Function	4-6
4.2.1 Overview	4-6
4.2.2 System Configuration	4-6
4.2.3 Communications Specifications	4-7
4.2.4 Connectors	4-8
4.2.5 Time Required for Transmission	4-9
4.2.6 Serial Communications Protocol	4-11
4.2.7 Opening the Serial Definition Window	4-17
4.2.8 General-purpose Serial Definitions	4-18
4.2.9 Saving General-purpose Serial Definition Data	4-21
4.2.10 Deleting General-purpose Serial Definition Data	4-21
4.3 LIO Function	4-22
4.3.1 Overview	4-22
4.3.2 LIO Specifications	4-23
4.3.3 Opening the Local I/O Definition Window	4-26
4.3.4 LIO Definitions	4-27
4.3.5 Saving LIO Definition Data	4-28
4.3.6 Deleting LIO Definition Data	4-28

4.4 CNTR Function	4-29
4.4.1 Overview	4-29
4.4.2 Counter Specifications	4-30
4.4.3 Counter Function Configuration	4-31
4.4.4 Pulse Count Method	4-32
4.4.5 Reversible Counter Mode	4-34
4.4.6 Coincidence Output and Interrupt Functions	4-34
4.4.7 PI Latch Function	4-36
4.4.8 Electronic Gear	4-36
4.4.9 Opening the Counter Module Definition Window	4-40
4.4.10 Defining Counter I/O	4-41
4.4.11 Setting I/O Data	4-42
4.4.12 Saving Counter I/O Definition Data	4-44
4.4.13 Deleting Counter I/O Definition Data	4-44
4.5 MECHATROLINK Functions	4-45
4.5.1 MECHATROLINK Overview	4-45
4.5.2 MECHATROLINK Communications Specifications	4-45
4.5.3 Master and Slaves	4-46
4.5.4 MECHATROLINK Connections	4-51
4.5.5 Opening the MECHATROLINK Window	4-52
4.5.6 Setting MECHATROLINK Definitions	4-53
4.5.7 Saving MECHATROLINK Definitions	4-56
4.5.8 Deleting MECHATROLINK Definitions	4-56
4.5.9 Ending MECHATROLINK Definitions	4-56
4.6 DeviceNet Functions	4-57
4.6.1 System Configuration	4-57
4.6.2 I/O Communications Function	4-58
4.6.3 Communications Specifications	4-58
4.6.4 260IF Module Setup	4-59
4.7 SVA Function	4-65
4.7.1 Overview	4-65
4.7.2 Separate and One-unit Systems	4-65
4.7.3 MP940 Servo Control Function	4-66
4.7.4 Setting Parameters of the SGDh SERVOPACK	4-70
4.8 Flash Memory Operation	4-77
4.8.1 Overview	4-77
4.8.2 Saving to Flash	4-77
4.8.3 Starting Flash Memory	4-79

4.1 MP940 Function Configuration

4.1.1 Overview

The MP940 is a single-axis controller with a bus connection to an SGDh SERVOPACK. Functional modules, such as communications, local I/O, and so on, are built into a single integrated unit.

The MP940 is configured from the functional modules shown in the following table, based on servo control. The initial settings for each of these functional modules must be made according to the module configuration definitions explained in this chapter.

■ MP940 Functional Modules

The functional modules for the MP940 are shown in the following table.

Functional Module	Details
MP940	CPU
SERIAL	Serial communications: RS-232C, RS-422/485
LIO	Local I/O: DI (8 bits), DO (8 bits), AO (1 word)
SVA	Motion functions
CNTR	Counter functions
MLINK or DevNet	MECHATROLINK interface or DeviceNet interface function

■ MP940 Function Block Diagram

The following is a block diagram showing MP940 functions.

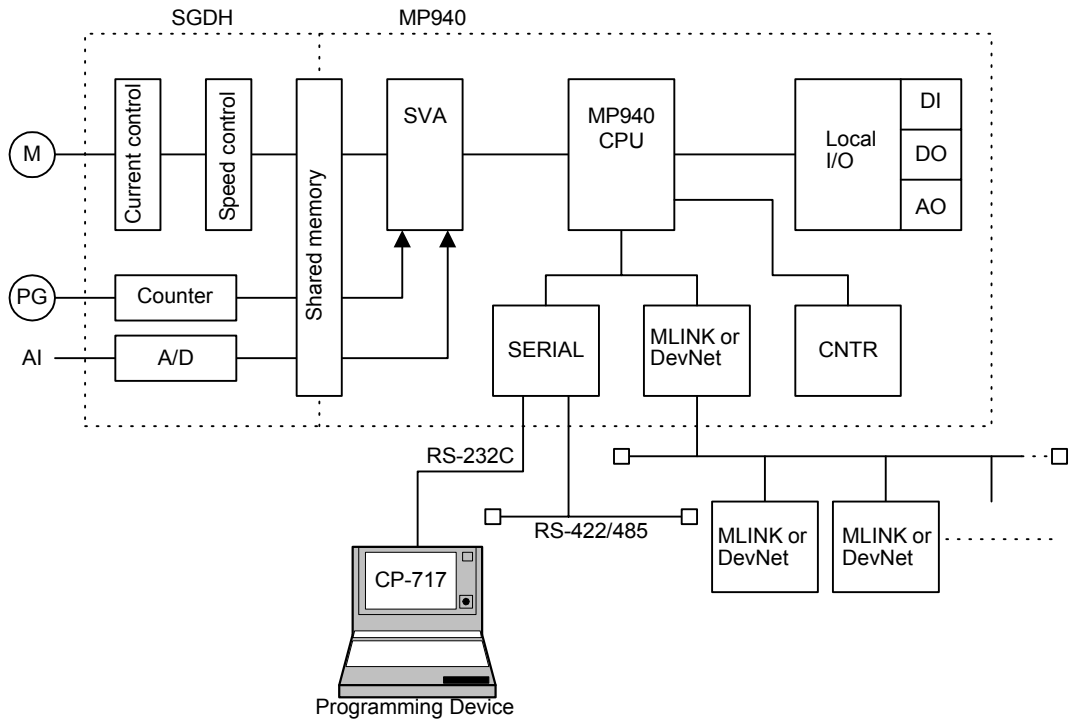

4.1.2 Simulated MP940 Building Block Configuration

The MP940 is a one-unit Machine Controller that saves space by incorporating into a single unit several hardware modules comprising separate functional units.

Parameter settings for each of these functional modules are made in the same operating environment as for building-block Machine Controllers. This makes it easy to simulate a building-block structure when developing an all-in-one configuration. The following diagram shows how the MP940 can be configured in such a simulated building-block structure.

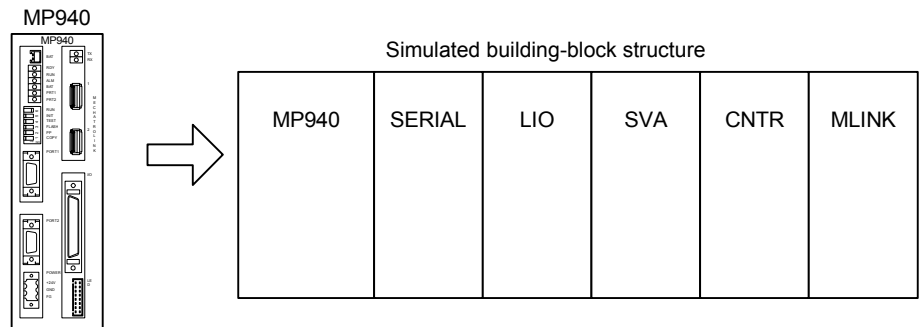

■ Main Window for Module Configuration Definitions

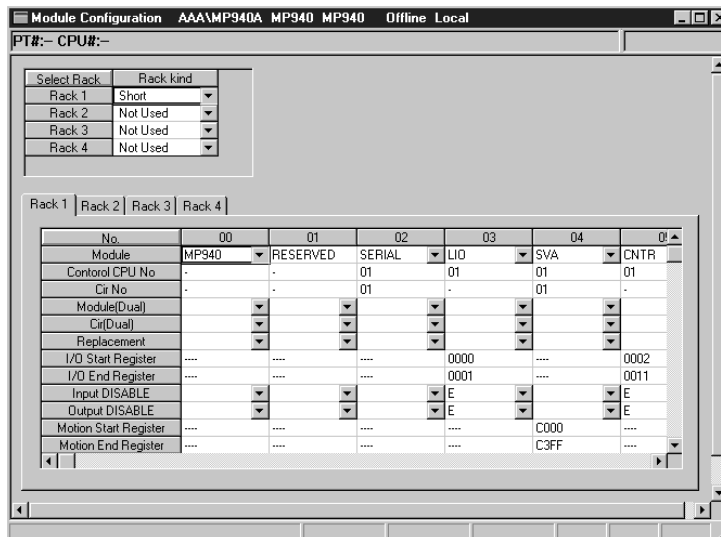

With the MP940, slot numbers 00 to 06 in Rack 1 must be set. Slot No. 1 is reserved for system use.

4.2 Serial Communications Function

4.2.1 Overview

The MP940 provides one serial communications interface for RS-232C and another for RS-422/485. Each interface can handle a variety of communications protocols, including the Yaskawa MEMOBUS communications protocol. The RS-232C interface at port 1 can also be used as an engineering port, making it possible to connect a CP-717 for MP940 programming and monitoring.

The MP940 will operate as either a master or slave, depending on the protocol set for serial communications.

With serial communications, data is sent and received using MSG-SND and MSG-RCV functions in a DWG/function program.

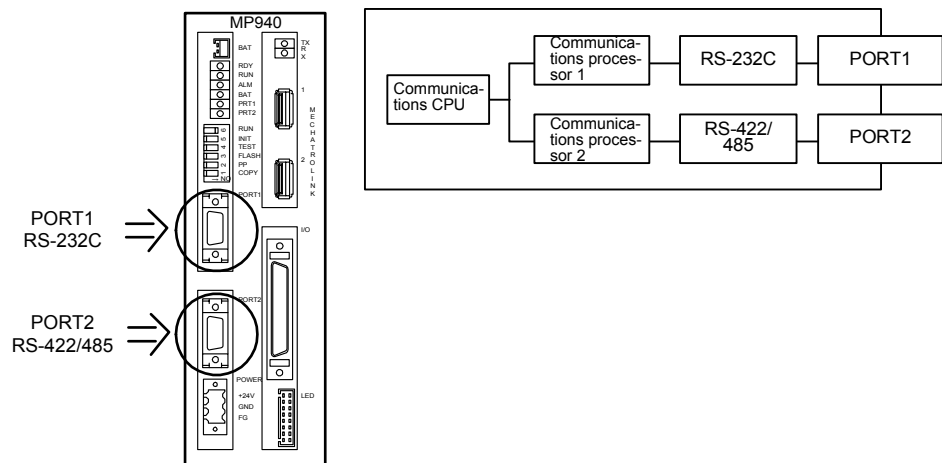

4.2.2 System Configuration

■ Standard System Configuration

In this example, a CP-717 Programming Device and a display panel are connected to an MP940 SERIAL Module.

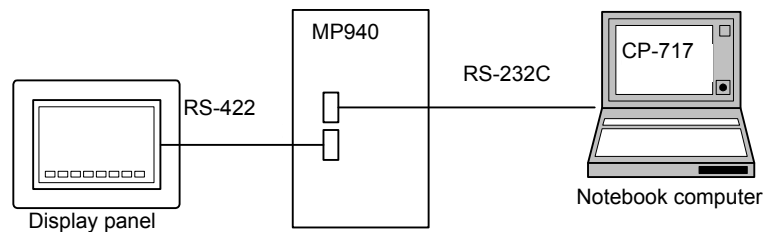

In this example, a CP-717 Programming Device is connected to the RS-232C port, and external devices are connected branching from the RS-485 port.

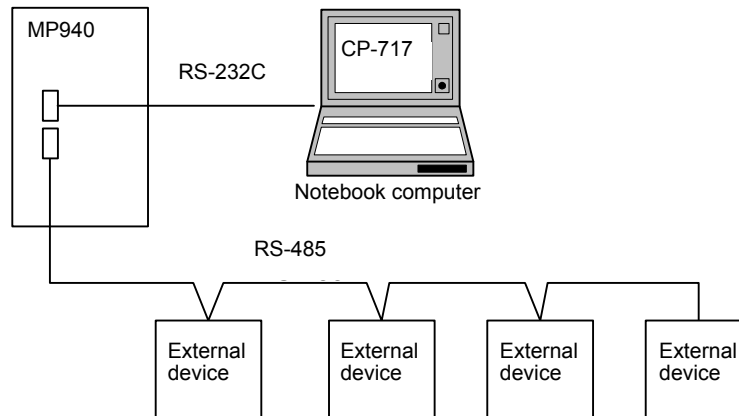

■ System Configuration with Controllers by Other Manufacturers

In this example, a MELSEC Controller by Mitsubishi Electric is connected to an MP940 in a serial circuit.

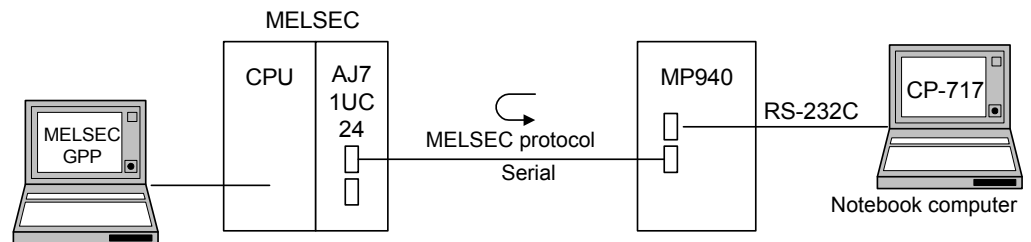

4

4.2.3 Communications Specifications

The following table shows the MP940 Module communications specifications for the serial communications function.

Table 4.1 Serial Communications Specifications

Item	Specifications
Interface	RS-232C: 1 circuit RS-422/485: 1 circuit
Connector	RS-232C (port 1): MDR 14-pin, female RS-422/485 (port 2): MDR 14-pin, female
Transmission Distance	RS-232C: 15 m max. RS-422/485: 300 m max.
Baud rate	RS-232C (port 1): 9600, 14400, 19200 bps RS-422/485 (port 2): 9600, 14400, 19200 bps
Synchronization Method	Non-synchronous (Start/stop synchronizing)
Communications Protocol	MEMOBUS (Master/Slave), MELSEC communications, no protocol
Connection Format	RS-232C: 1:1 RS-422: 1:1 RS-485: 1:N
Communications Format (Can be set.)	Data length: 7/8 bits Stop bits: 1/2 bits (port 1 only) Always 1 for port 2. Parity bits: Even, odd, or none

4.2.4 Connectors

■ Serial Port 1

The MP940 can communicate with communications devices on the MEMOBUS Network by means of RS-232C via serial port 1.

Connect a Programming Device (a personal computer with an RS-232C interface) to serial port 1.

Connecting a Programming Device

The following diagram shows an example of a Programming Device connected to serial port 1.

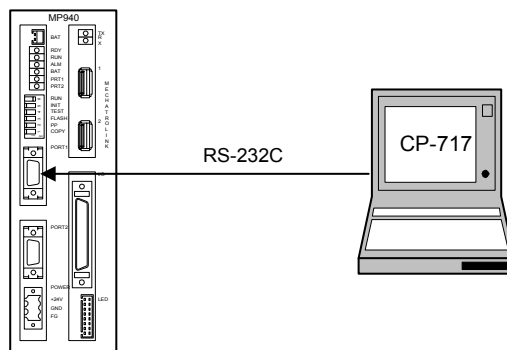

Connector Pin Arrangement and Signal Names

The following table shows the connector pin arrangement and signal names for serial port 1.

No.	Signal Name	Remarks	No.	Signal Name	Remarks
1	TXD	Transmission data	8		
2			9		
3	RXD	Receiving data	10		
4			11		
5			12	RTS	Request to send
6	CTS	Clear to send	13	-	
7			14	GND	Signal ground

- Connector at Module: 10214-52A2JL (3M)
- Connector at Cable: 10114-3000VE (3M)
- Shell: 10314-52A0-008 (3M)

4.2.5 Time Required for Transmission

This section explains the time required for signal transmissions between a master and slave, taking the MEMOBUS protocol as an example.

■ Overview

In a MEMOBUS System, the time required for signal transmissions between a master and slave can be roughly calculated from the following seven items.

- Processing time for a command message from the master
- Modem lag time at the master
- Command message transmission time
- Slave processing time
- Modem lag time at the slave
- Response message transmission time
- Time for master processing of response message

To calculate the total processing time required when multiple slaves are connected to the same master port, calculate the time required for each individual slave and then total them.

■ External Time Requirement Standards

The times for the seven items are explained in detail below.

Processing Time for a Command Message from the Master

This is the time required for the computer to prepare a command message up to the MEMOBUS port. This time depends on the processing time for the particular master.

For a Machine Controller, it depends on the scan time and is normally one scan.

Modem Lag Time at the Master

This is the time from when the modem at the master receives a request-to-send (RTS) signal from the master until a clear-to-send (CTS) signal is returned to the master.

With a Yaskawa modem, this time is 5 ms or less, so it can basically be ignored. If no modem is used at all, then this time lag will not exist.

Command Message Transmission Time

This is the time required for the command message to be sent from the master's communication port.

This time depends on the message length and the baud rate. It can be calculated by means of the following equation:

$$\text{Transmission time} = \frac{(\text{Number of command message characters}) \times (\text{Number of bits per character}) \times 1,000}{\text{Baud rate}} \text{ (ms)}$$

The number of bits per character includes not only the number of data bits (8 or 7), but also the number of start bits (1), stop bits (1 or 2), and parity bits (1 or 0).

Slave Processing Time

This is the time required, after the Slave has received the command message from the master, for the slave to process the message and prepare a response message to the master, up to the MEMOBUS port.

This time is related to the Machine Controller scan time and the number of coils, registers, etc., designated in the command message, as well as to the number of processes performed by the Machine Controller in one scan.

With the MP940, all functions are processed within one scan, so this time is equivalent to the time required for one scan.

Modem Lag Time at the Slave

This is the time from when the modem at the slave receives a request-to-send (RTS) signal from the slave until a clear-to-send (CTS) signal is returned to the slave.

With a Yaskawa modem this time is 5 ms or less, so it can basically be ignored. If no modem is used at all, then this time lag will not exist.

Response Message Transmission Time

This is the time required for sending the response message from the slave's communications port. It can be calculated by means of the following equation:

$$\text{Transmission time} = \frac{(\text{Number of characters in response message}) \times (\text{Number of bits per character}) \times 1,000}{\text{Baud rate}} (\text{ms})$$

The number of bits per character includes not only the number of data bits (8 or 7), but also the number of start bits (1), stop bits (1 or 2), and parity bits (1 or 0).

Time for Master Processing of Response Message

This is the time required for a master such as a computer to process the response message after receiving it from the slave.

This time depends on the processing time for the particular master.

It depends on the Machine Controller's scan time, and normally requires one or two scans.

4.2.6 Serial Communications Protocol

The MP940 Module can handle various communications protocols, including the standard Yaskawa MEMOBUS communications protocol.

It also provides the MELSEC communications protocol as a standard function for connecting to Mitsubishi Electric controllers.

■ MEMOBUS Communications

MEMOBUS communications are message transmissions following the MEMOBUS protocol.

Table 4.2 Correspondence Between MEMOBUS Reference and Register Numbers

Classification	MEMOBUS Reference Numbers *1	MEMOBUS Commands *2	MP940	
			Leading Number *3	Register Number *4
Coils	000001 - 0XXXXXX	01H, 05H, 0FH	000000-	MB000000-
Input relays	100001 - 1XXXXXX	02H	00000-	IB00000-
Input registers	300001 - 3XXXXXX	04H	00000-	IW0000-
Holding registers	400001 - 4XXXXXX	05H	00000-	MW00000-

- * 1. MEMOBUS reference numbers are leading numbers used by Yaskawa MEMOBUS protocol messages. They are allocated in the ranges shown in the table to coils, input relays, input registers, and holding registers. The first digit represents the classification, and the following digits are the start number beginning from 1.
- * 2. MEMOBUS commands are command codes set in the MEMOBUS protocol.
- * 3. Leading numbers are initial addressed used by the MP940, and they all begin from 0 (zero).
- * 4. Register numbers are numbers for each register that correspond to the leading numbers. These register numbers can be designated for offset by the system functions MSG-SND and MSG-RCV, along with coils, input relays, input registers, and holding registers.
For example, with Yaskawa GL:

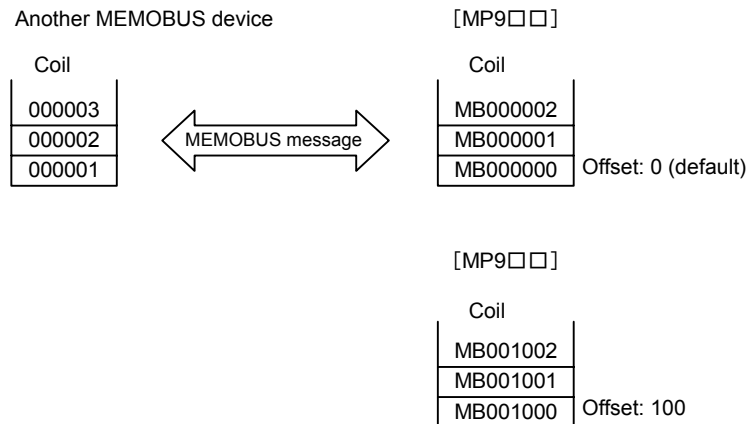

■ MELSEC Communications

MELSEC Communications Specifications

The following table shows the general specifications for MELSEC communications, and which of these specifications are supported by the MP940.

Table 4.3 MELSEC Communications Specifications

	General MELSEC Specifications		MELSEC Specifications Supported by the MP940
Transmission Method	RS-232C: Half-duplex, full-duplex RS-422: Half-duplex		RS-232C: Full-duplex (Half-duplex for procedural) RS-485: Half-duplex
Synchronization	Start-stop synchronization		Start-stop synchronization
Baud Rate	300/600/1200/2400/4800/9600/19200 bps		19,200 bps
Data Format	Data: 8 or 7 bits Parity: Odd, even, none Stop bits: 1 or 2 bits		Data: 8 or 7 bits Parity: Odd, even, none Stop bits: 1 or 2 bits
Error Detection	With or without checksum		With checksum
DTR/DSR (ER/DR) Control	Yes/No (RS-232C only)	Both controls are possible.	None
DC1/DC3, DC2/DC4 Control	Yes/No		
Transmission Protocol	Special protocol		Only protocol type 1 is supported.
	Type 1	(1:1, 1:N, N:N)	
	Type 2		
	Type 3		
	Type 4		
No protocol (1:1, 1:N)			
Full duplex (1:1)			

Message Flow

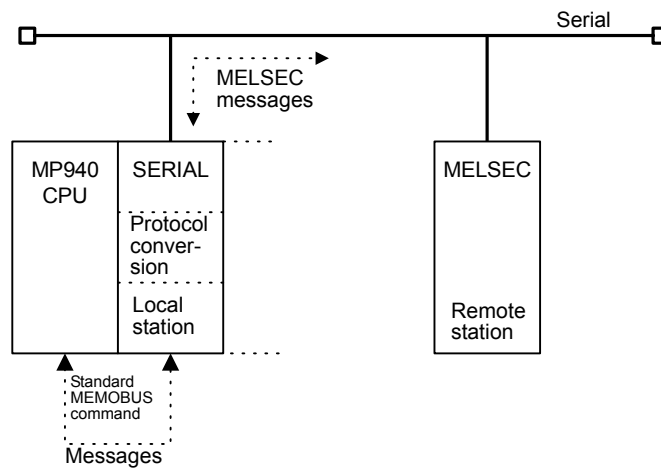

All standard MEMOBUS messages are exchanged between the MP940 and the SERIAL Module.

The SERIAL Module communicates with the MELSEC Controller and performs standard MEMOBUS and MELSEC message conversion processing. There is no need for the MELSEC message configuration to be recognized by the user application. The user can easily communicate with the MELSEC Controller by using the MSG-SND and MSG-RCV functions and specifying MELSEC as the transmission protocol in the SERIAL parameter settings.

Due to MELSEC protocol-specific restrictions or MELSEC sequencer-specific restrictions in MEMOBUS to MELSEC format conversion, there are stricter restrictions than in the MEMOBUS protocol, such as the number of words read from a register. Carefully read the manuals relating to the devices being connected.

Also be sure to refer to the manual relating to MELSEC protocol type 1 commands.

MELSEC Commands

The following table shows the MELSEC ACPU commands that are supported by the SERIAL Module, and the corresponding MEMOBUS command codes.

Table 4.4 MELSEC ACPU Commands

Command	Description	Qty	SERIAL Support*	MEMOBUS Command
BR	Reads bit devices in 1-point units	256 points	No	---
WR	Reads bit devices in 16-point units	32 words (512 points)	Yes	01H/02H
	Reads word devices in 1-point units	64 points	Yes	03H/04H
BW	Writes bit devices in 1-point units	160 points	No	---
WW	Writes bit devices in 16-point units	10 words (160 points)	Yes	0FH
	Writes word devices in 1-point units	64 points	Yes	10H
BT	Randomly specifies, sets, and resets bit devices and device numbers in 1-point units	20 points	No	---
WT	Randomly specifies, sets, and resets bit devices and device numbers in 16-point units	10 words (160 points)	No	---
	Randomly specifies, sets, and resets word devices and device numbers in 1-point units	10 points	No	---
BM	Sets the bit devices to be monitored in 1-point units	40 points	No	---
WM	Sets the bit devices to be monitored in 16-point units	20 words (320 points)	No	---
	Sets the word devices to be monitored in 1-point units	20 points	No	---
MB	Monitors devices for which monitor data registration has been performed (in bit units)	---	No	---
MN	Monitors devices for which monitor data registration has been performed (in word units)	---	No	---
ER	Reads extension file registers in 1-point units	64 points	No	---
EW	Writes extension file registers in 1-point units	64 points	No	---
ET	Randomly specifies block numbers and device numbers, and writes to the extension file registers in 1-point units	10 points	No	---
EM	Registers the extension file registers to be monitored in 1-point units	20 points	No	---
ME	Monitors extension file registers for which monitor data registration has been performed	---	No	---
CR	Reads the data in the buffer memory	64 words	No	---
CW	Writes the data in the buffer memory	64 words	No	---
TR	Reads the contents of the buffer memory of the special function unit	64 words	No	---
TW	Writes data to the buffer memory of the special function unit	64 words	No	---
MR	Reads the main sequence program	64 steps	No	---
SR	Reads the sub-sequence program	64 steps	No	---
MW	Writes the main sequence program	64 steps	No	---
SW	Writes the sub-sequence program	64 steps	No	---

Command	Description	Qty	SERIAL Support*	MEMOBUS Command
UR	Reads the main microcomputer program	128 bytes	No	---
VR	Reads the sub-microcomputer program	128 bytes	No	---
UW	Writes the main microcomputer program	128 bytes	No	---
VW	Writes the sub-microcomputer program	128 bytes	No	---
KR	Reads the comment data	128 bytes	No	---
KW	Writes the comment data	128 bytes	No	---
PR	Reads the parameter contents	128 bytes	No	---
PW	Writes the parameter contents	128 bytes	No	---
PS	Recognizes and checks the rewritten parameter contents	---	No	---
RR	Requests for remote RUN/STOP	---	No	---
RS				
PC	Reads the PLC model name	---	No	---
GW	Turns a global signal ON/OFF	1 point	No	---
On demand	Issues a request to send from the sequencer CPU	1,760 words max.	No	---
TT	Loopback test	254 characters	Yes	08H

* Yes: Command supported by the SERIAL Module.

No: Command not supported by the SERIAL Module.

Note: Special AnACPU commands are not supported. Use the common ACPU commands for AnACPU access. The AnACPU expansion registers cannot be accessed.

4

MELSEC Devices

The following table shows the MELSEC bit devices and word devices that can be accessed from the MP940.

The MP940 register numbers corresponding to the MELSEC device range and the MEMO-BUS commands used are also shown in the table.

Table 4.5 MELSEC Bit Devices

Device	Device Range for Common ACPU Commands	Decimal/Hexadecimal	MEMOBUS Command	Leading No.	Register No.*
X	X0000 to X07FF	Hexadecimal	02H: Input relays	0 to 2047	MB000000 to MB00127F
Y	Y0000 to Y07FF	Hexadecimal	01H/0FH: Coils	0 to 2047	MB000000 to MB00127F
M	M0000 to M2047	Decimal	01H/0FH: Coils	2048 to 4095	MB001280 to MB00255F
L	L0000 to L2047				
S	S0000 to S2047				
M	M9000 to M9255	Decimal	01H/0FH: Coils	4096 to 4351	MB002560 to MB00271F
B	B0000 to B03FF	Hexadecimal	01H/0FH: Coils	4352 to 5375	MB002720 to MB00335F

Device	Device Range for Common ACPU Commands	Decimal/Hexadecimal	MEMOBUS Command	Leading No.	Register No.*
F	F0000 to F0255	Decimal	01H/0FH: Coils	5376 to 5631	MB003360 to MB00351F
TS	TS000 to TS255	Decimal	02H: Input relays	2048 to 2303	MB001280 to MB00143F
TC	TC000 to TC255	Decimal	02H: Input relays	2304 to 2559	MB001440 to MB00159F
CS	CS000 to CS255	Decimal	02H: Input relays	2560 to 2815	MB001600 to MB00175F
CC	CC000 to CC255	Decimal	02H: Input relays	2816 to 3071	MB001760 to MB00191F

* Register number offsets can be specified for both input relays and coils by the MSG-SND and MSG-RCV system functions.

Table 4.6 MELSEC Word Devices

Device	Device Range for Common ACPU Commands	Decimal/Hexadecimal	MEMOBUS Command	Leading No.	Register No.*
TN	TN111 to TN255	Decimal	04H: Input registers	0 to 255	MW00000 to MW00255
CN	CN000 to CN255	Decimal	04H: Input registers	256 to 511	MW00256 to MW00511
D	D0000 to D1023	Decimal	03H/10H: Holding registers	0 to 1023	MW00000 to MW01023
D (Special)	D9000 to D9255	Decimal	03H/10H: Holding registers	1024 to 1279	MW01024 to MW01279
W	W0000 to W03FF	Hexadecimal	03H/10H: Holding registers	1280 to 2303	MW01280 to MW02303
R	R0000 to R8191	Decimal	03H/10H: Holding registers	2304 to 10495	MW02304 to MW10495

* Register number offsets can be specified for both input registers and holding registers by the MSG-SND and MSG-RCV system functions.

4.2.7 Opening the Serial Definition Window

The Serial Definition Window is opened from the Module Configuration Definition Window.

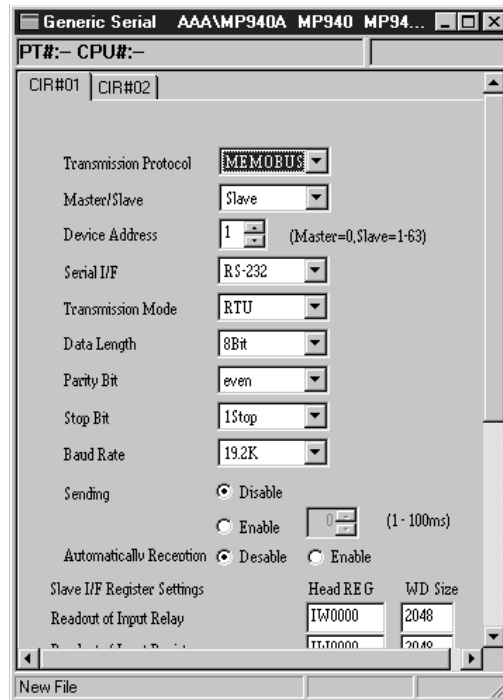

4

■ Configuration Data

Generic serial configuration data set in the Module Configuration Definition Window is displayed below the window title.

Configuration Data	Contents
PT#	When online, the number of the logical port being used is displayed.
CPU#	When online, the number of the CPU that is logged in is displayed.
Latch No.	The latch number (01#) defined for the SERIAL Module is displayed.
Slot No.	The slot number (02#) defined for the SERIAL Module is displayed.

■ Tab Window

Sets the various SERIAL module parameters. It is configured from two windows, according to the port.

Tab Window	Contents
CIR#01	Sets the RS-232C communications parameters.
CIR#02	Sets the RS-485 communications parameters.



When the Serial Definition Window is opened for the first time without any settings having previously been made, a new message box will be displayed. Click the **OK** Button and then proceed to the next operation.

4.2.8 General-purpose Serial Definitions

There are definition tabs for two circuits in the General-purpose Serial Settings Window. Use both these tabs when making definitions.

■ Serial Communications Definitions

The following table shows the contents of the serial communications definitions.

Item	Contents
Circuit No.	Select by CIR# in Tab Window.
Transmission Protocol	Select MEMOBUS, MELSEC, or no protocol.
Master/Slave	Select Master or Slave operation.
Device Address	Set 0 for the Master, or 1 to 63 for Slaves.
Serial Interface	Select RS-232C, RS-485, or RS-422.
Transmission Mode	Select RTU, ASCII, or none.
Data Length	8 bits or 7 bits
Parity Bit	Even, odd, or none
Stop Bits	1 or 2
Baud Rate	Select the baud rate (unit: bps).
Transmission Delay	Set the delay time for the send/receive function (MSG-SND/RCV) until a message is sent.
Automatic Reception	Specify whether there will be an automatic response to requests from the master.
Reading Input Relays	Set the leading number and range for input relays read for automatic responses.
Reading Input Registers	Set the leading number and range for input registers read for automatic responses.
Reading/Writing Coils	Set the leading number and range for coils read and written for automatic responses.
Reading/Writing Holding Registers	Set the leading number and range for holding registers read and written for automatic responses.
Coil/Holding Register Write Range	Set the write range for coils and holding registers read and written for automatic responses.

■ Transmission Protocol

- MEMOBUS: Yaskawa standard MEMOBUS protocol
- MELSEC: Special protocol (control protocol format 1) for Mitsubishi Electric general sequencer controller
- No protocol: Any data received at any time according to user application program.

■ Serial Interface

RS-232C for CIR#01, and RS-485/422 for CIR#02

Only 1 stop bit for CIR#02.

■ Transmission Mode

- RTU: Specifies RTU Mode for MEMOBUS protocol.
- ASCII: Specifies ASCII Mode for MEMOBUS protocol.
- None: For MELSEC or no-protocol.

■ Transmission Delay

When the transmission delay is designated, a delay time of 1 to 100 ms is set for the start of data transmission.

- Master: The delay time from when the MSG-SND function is executed until the command is sent.
- Slave: The delay time from when the MSG-RCV function receives the command until the response is sent.

■ Automatic Response

This is the set range for relays, registers, and coils that are used for sending automatic response messages when requests are received from the master. Therefore, it is enabled for slaves.

Automatic response does not need to be set when there are no messages to be transferred between the master and slaves. If the MSG-RCV function is already being used in a ladder program to send response messages, then turn OFF the automatic reception so that processing is not duplicated.

As the system default, response messages are sent within the set ranges for the parameters from here onwards.

■ Leading Register Number and Number of Words

The following table shows the leading register numbers and the number of words.

Item		MP940
Input Relay Read	Leading register	IW0000
	No. of words	2,048
Input Register Read	Leading register	IW0000
	No. of words	2,048
Coil Read/Write	Leading register	MW00000
	No. of words	32,768
Holding Register Read/Write	Leading register	MW00000
	No. of words	32,768

■ General-purpose Serial Parameter Default Values

The following table shows the default values for the general-purpose serial parameters.

Item	CIR01	CIR02
Rack No.	01	01
Slot No.	02	02
Circuit No.	01	02
Transmission Protocol	MEMOBUS	MEMOBUS
Master/Slave	Slave	Slave
Device Address	01	02
Serial Interface	RS-232C	RS-485
Transmission Mode	RTU	RTU
Data Length	8 bits	8 bits
Parity Bits	Even	Even
Stop Bits	1	1
Baud Rate	9,600 bps	9,600 bps
Transmission Delay	Not designated.	Not designated.
Automatic Reception	Not designated.	Not designated.
Input Relay Read	IW0000/2048	IW0000/2048
Input Register Read	IW0000/2048	IW0000/2048
Coil Read/Write	MW00000/32768	MW00000/32768
Holding Register Read/ Write	MW00000/32768	MW00000/32768
Coil/Holding Register Write Range	MW00000/32767	MW00000/32767

4.2.9 Saving General-purpose Serial Definition Data

1. Select **Save (S)** from the **File (F)** Menu in the General-purpose Serial Definition Window.
2. Click the **Yes (Y)** Button in the message box.
3. Click the **OK** Button in the message box.

4.2.10 Deleting General-purpose Serial Definition Data

1. Select **Delete (D)** from the **File (F)** Menu in the General-purpose Serial Definition Window.
2. Click the **Yes (Y)** Button in the message box.



When the delete function is executed, the general-purpose serial definition data for both circuits will be deleted.



Port for Connecting to the CP-717

Use the MEMOBUS specifications for the port for connecting to the CP-717. The initial values for new settings will be the MEMOBUS specifications. The maximum baud rate for connecting to the CP-717 is 19.2 Kbps.

4.3 LIO Function

This section explains the local I/O (LIO) function.

4.3.1 Overview

The LIO Module provides 8 digital inputs (DI), 8 digital outputs (DO), and one analog output (AO) channel. The I/O timing has a regular cycle for each of the MP940 levels: System (S), high-speed (High), and low-speed (Low).

One digital input point can be set for interrupt enable/disable operations.

Connector	Number of circuits
Discrete inputs	8 pts.
Discrete outputs	8 pts.
Analog input	1 channel
Analog output	1 channel

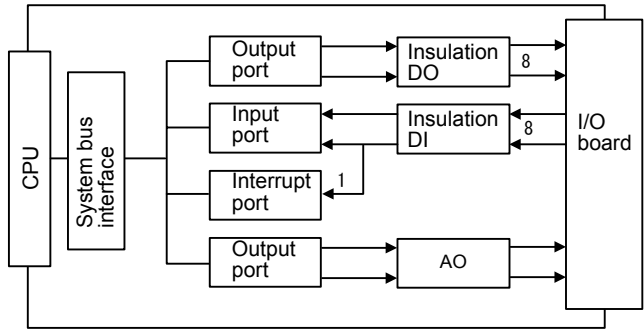
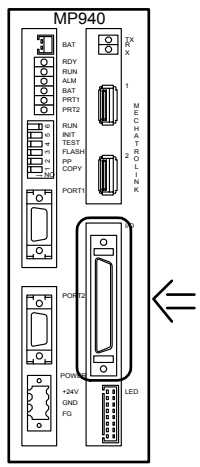

4.3.2 LIO Specifications

The following tables show the hardware specifications for the LIO function.

■ Digital Input Circuits

Item	Specifications
Number of Input Points	8 pts./common
Input Format	Combined sinking/sourcing
Input Type	Type 1 (JIS-B3501)
Isolation	Photocoupler isolation
Operating Voltage	17.4 to 28.8 VDC 35 VDC (peak voltage)
Rated Current	5.3 mA
Input Impedance	Approx. 4.4 k Ω
Working Voltage	ON voltage: 15 VDC min. OFF voltage: 5 VDC min.
OFF Current	0.9 mA max.
Response Time	OFF to ON 0.5 ms max. ON to OFF 1.5 ms min.
Digital Input Circuit	
Register Numbers	IW0000 (default): Can be set on the Module Configuration Definition Screen. IB00000: Interrupt input "Used/Not used" can be set.

■ Digital Output Circuits

Item	Specifications
Number of Output Points	8 pts./common
Output Format	Sinking outputs
Output Type	Transistor outputs
Isolation	Photocoupler isolation
Load Voltage	19.2 to 28.8 VDC 35 VDC (peak voltage)
Load Current	0.1 A/circuit; 0.8 A/common
ON Voltage	1.0 V max.
External Power Supply	24 VDC \pm 20% at 15 mA
Output Protection	One fuse per common
Fuse Rating	1.5 A (opening time: 5 s max. at 3 A)
Response Time	OFF to ON 0.25 ms max. ON to OFF
Digital Output Circuit *	
Register Number	OW0000 (default): Can be set on the Module Configuration Definition Screen.

* DO-07 is the conformity output signal when the CNTR fixed parameter for the conformity detection function is set to enabling using the detection function.

IMPORTANT

A fuse is inserted in the output common line of the Output Modules as a protective circuit. If the output short-circuit is incomplete, there is a risk that the fuse may not blow.

■ Analog Input

The SGDH analog input circuit is used for an analog input. Input data is stored in the register specified on the LIO Definition Screen, via 2-port RAM.

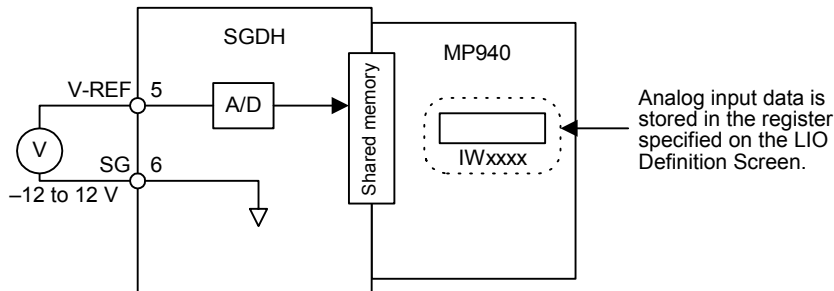

Item	Contents
Input Voltage Input Impedance	±12 V (max.) Approx. 14 kΩ
Input Characteristics*	<p style="text-align: center;"> $V \text{ data} = \text{Input register data} \times 15/32,767$ $\text{Input register data} = V \text{ data} \times 32,767/15$ </p>
Analog Input Circuit	
Register Number	IW0001 (default): Can be set on the Module Configuration Definition Screen.

* Analog input linearity is only assured between -12.0 and 12.0 (V).

■ Analog Output

Item	Contents
D/A Output Command Output Range	16 bits 0 to ± 10 V
Output Characteristics*	<p style="text-align: center;">V</p> <p style="text-align: center;">+10.75 +10 -10 -10.75</p> <p style="text-align: center;">-32768 -30481 30480 32767</p> <p style="text-align: center;">V data = Output register data × 10.75/32,767 Output register data = V data × 32,767/10.75</p>
Analog Output Circuit	
Register Number	OW0001 (default): Can be set on the Module Configuration Definition Screen.

* Analog output linearity is only assured between -10.0 and 10.0 (V).

4.3.3 Opening the Local I/O Definition Window

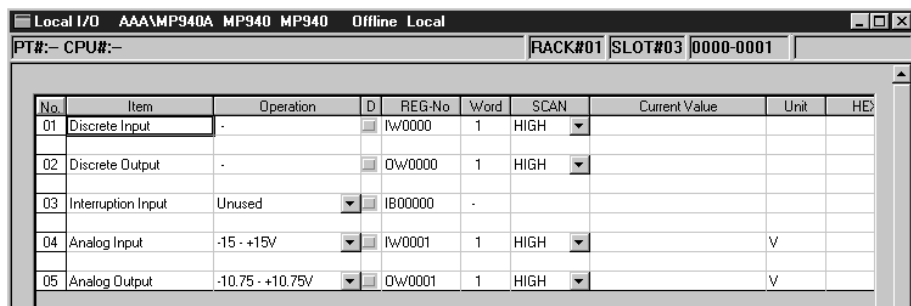

The Local I/O Definition Window is opened from the Module Configuration Definition Window. Refer to the sections on opening individual Module Definition Windows.

■ Configuration Information

The LIO configuration information set on the Module Configuration Definition Window is displayed under the window title.

Configuration Information	Contents
PT#	When online, the number of the logical port being used is displayed.
CPU#	When online, the number of the CPU that is logged in is displayed.
Latch No.	The latch number (01#) defined for the LIO is displayed.
Slot No.	The slot number (03#) defined for the LIO is displayed.
Register Range	The I/O register range is displayed.



When the Local I/O Definition Window is opened for the first time without any settings having previously been made, a new message box will be displayed. Click the **OK** Button, and then proceed to the next operation.

4.3.4 LIO Definitions

Set the various I/O operations and the disable conditions.

■ Set Items

Set Item	Contents
No.	This is the input item number
Item	The I/O item name is displayed.
Operation	Sets the operation for the input item. The settings are automatic for all but interrupt input items.
D	Sets the register disable. <input type="checkbox"/> Enable <input checked="" type="checkbox"/> Disable
REG-No.	The I/O register number allocated to the I/O item is displayed. It is set automatically and cannot be changed.
Word	This is the number of words in the I/O register allocated to the I/O item. It is set automatically and cannot be changed.
SCAN	Sets the transmission processing scan. • SYSTEM: System scan • HIGH: High-speed processing scan • LOW: Low-speed processing scan
Current Value	In the Online Mode, the present value of the Machine Controller register will be displayed. Discrete I/O present values are displayed in binary. Discrete output present values can be changed. Interrupt present values are displayed as ON or OFF. As present values are input, they are stored in the Machine Controller register as soon as they are determined. In Offline Mode, nothing is displayed.
Unit	Displays the unit of the I/O item values.
HEX	The data in the “Current Value” space is displayed in hexadecimal. In Offline Mode, nothing is displayed.

4.3.5 Saving LIO Definition Data

1. Select **Save (S)** from the Local I/O Definition **File (F)** Menu.
2. Click the **Yes (Y)** Button in the message box.
3. Click the **OK** Button in the message box.

4.3.6 Deleting LIO Definition Data

1. Select **Delete (D)** from the Local I/O Definition **File (F)** Menu.
2. Click the **Yes(Y)** Button in the message box.

4.4 CNTR Function

This section explains the MP940 counter function (CNTR).

4.4.1 Overview

The MP940's counter function supports one pulse input (PI). Pulses can be received with a 5-V differential interface.

The MP940 has a latch input signal, enabling counter values to be latched on the latch signal. It also has a coincidence detection signal output, so the CPU and external devices are notified when an internally set value matches the counter's current count.

Counted data is input in a regular cycle with each CPU scan (system, high-speed, or low-speed).

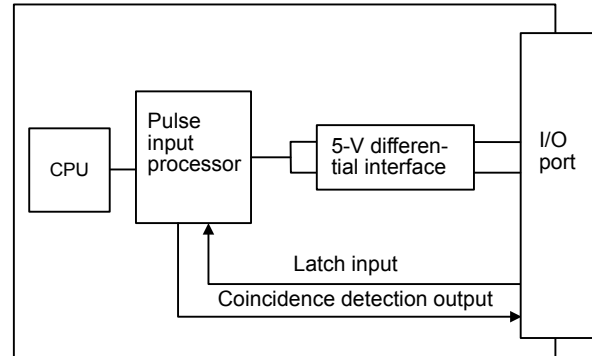
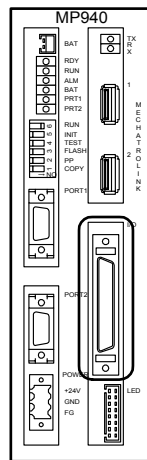

4.4.2 Counter Specifications

The following table shows the Counter hardware specifications.

Item	Contents	Remarks	
Pulse Input	Number of Input Circuits	1 pt.	
	Input Method	<ul style="list-style-type: none"> • A/B method (x1/x2/x4) • Up/Down method (x1/x2) • Sign method (x1/x2) 	Soft switch
	Counter Function	Reversible counter	Fixed.
	Response Frequency	1 MHz	
	Pulse Input Circuit		
Latch Input	Number of Input Circuits	1 pt.	
	Input Type	Current sourcing, photocoupler isolation	
	Input Voltage	24, 12, or 5 VDC	
	Input Current		
	Latch Input Circuit		
Coincidence Output	Number of Output Circuits	1 pt. (Uses DO-07 digital output.)	
	Output Method	Sinking output, photocoupler isolation	
	Rated Voltage and Current	24 VDC, 100 mA	
	General Output Circuit	Refer to the LIO function specifications. DO-07 is the coincidence output signal when coincidence detection is enabled using a CNTR fixed parameter.	

4.4.3 Counter Function Configuration

With the counter, functions selected by fixed parameters and output registers are executed and status and counter values are stored in input registers.

The following diagram shows the data flow for the counter.

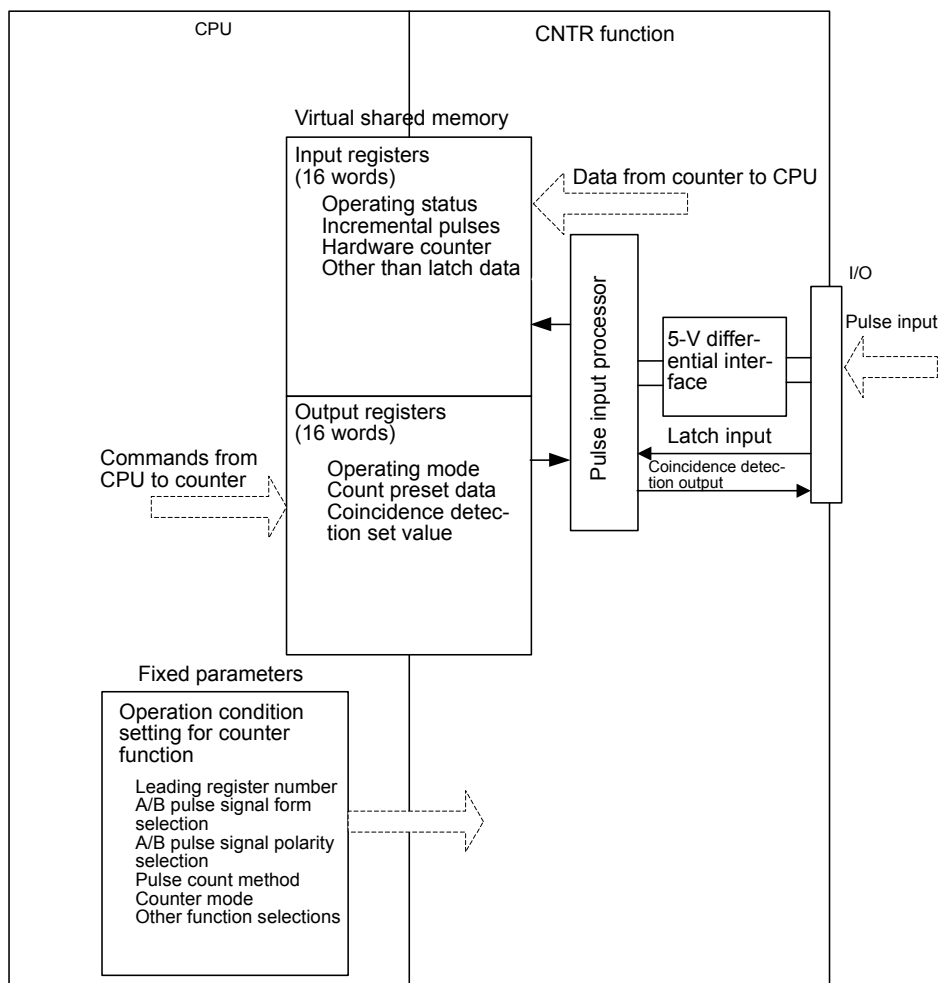

4.4.4 Pulse Count Method

The methods shown below can be selected by means of fixed parameter 5 (PI Latch Detection).

Table 4.7 Types of Pulse Count Method

Measurement	Pulse count method *1	Multiplier *2	Remarks
Reversible counter	Sign method	x1	
		x2	
	A/B method	x1	
		x2	
		x4	
	Up/Down method	x1	
		x2	

* 1. Pulse Count Methods

• Sign Method

(Positive logic, 5-V differential input)

UP count with A-pulse inputs when B-pulse inputs are low.

DOWN count with A-pulse inputs when B-pulse inputs are high.

(Negative logic, 5-V differential input)

DOWN count with A-pulse inputs when B-pulse inputs are high.

UP count with A-pulse inputs when B-pulse inputs are low.

• A/B Method

(Positive/Negative logic)

UP count when A-pulse input phase lags B pulses.

DOWN count when A-pulse input phase leads B pulses

• UP/DOWN Method

(Positive/Negative logic)

A-pulse inputs: Incrementing pulses

B-pulse inputs: Decrementing pulses

* 2. Multipliers

(Positive logic)

x1: Count on A-pulse rising edge.

x2: Count on A-pulse leading and trailing edges.

x4: Count on A-pulse and B-pulse leading and trailing edges.

















































(Negative logic)

x1: Count on A-pulse trailing edge.

x2: Count on A-pulse trailing and rising edges.

x4: Count on A-pulse and B-pulse trailing and rising edges.

Table 4.8 Timing of External Input Pulses

Pulse Count Method		Polarity	Up Count (Forward)	Down Count (Reverse)
Sign method (for 5-V differential input)	x1	Positive logic	A pulses  B pulses  LOW	A pulses  B pulses  HIGH
		Negative logic	A pulses  B pulses  HIGH	A pulses  B pulses  LOW
	x2	Positive logic	A pulses  B pulses  LOW	A pulses  B pulses  HIGH
		Negative logic	A pulses  B pulses  HIGH	A pulses  B pulses  LOW
A/B method	x1	Positive logic	A pulses  B pulses 	A pulses  B pulses 
		Negative logic	A pulses  B pulses 	A pulses  B pulses 
	x2	Positive logic	A pulses  B pulses 	A pulses  B pulses 
		Negative logic	A pulses  B pulses 	A pulses  B pulses 
	x4	Positive logic	A pulses  B pulses 	A pulses  B pulses 
		Negative logic	A pulses  B pulses 	A pulses  B pulses 
UP/DOWN method	x1	Positive logic	A pulses  B pulses Fixed at low or high.	A pulses Fixed at low or high. B pulses 
		Negative logic	A pulses  B pulses Fixed at low or high.	A pulses Fixed at low or high. B pulses 
	x2	Positive logic	A pulses  B pulses Fixed at low or high.	A pulses Fixed at low or high. B pulses 
		Negative logic	A pulses  B pulses Fixed at low or high.	A pulses Fixed at low or high. B pulses 

4.4.5 Reversible Counter Mode

In Reversible Counter Mode, the count goes up or down according to A/B pulse inputs.

The following functions are available in Reversible Counter Mode depending on the output register designation.

- Count Prohibit: The counter is disabled from counting.
- Count Value Preset: The count value is forcibly changed.
- PI Latch Detection: Counter values at the time of external signal inputs are stored in memory.
- Coincidence Detection: Outputs an external output signal when the output register coincidence detection set value matches the counter present value.

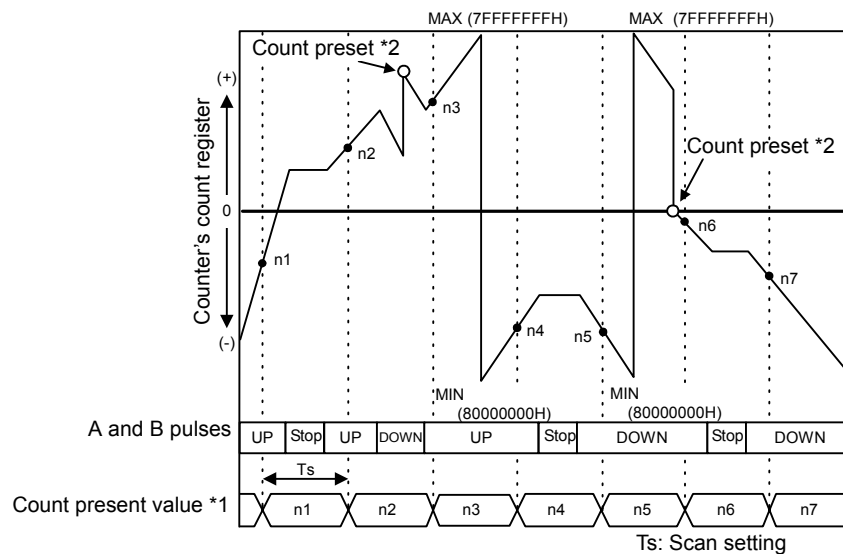

- * 1. Count present value = Hardware counter (ILxxxx+4)
- * 2. Count preset = Count preset data (OLxxxx+2)

4.4.6 Coincidence Output and Interrupt Functions

With the coincidence output and interrupt functions, an external output signal (coincidence detection signal) is output when a preset output register (Coincidence Detection Set Value: OL0006) matches the counter present value, and an interrupt signal is output to the CPU Module.

The coincidence output function is enabled by a setting in fixed parameter 6 (Coincident Detection).

The coincidence interrupt function is enabled by a further setting in fixed parameter 7 (Coincident IRQ).

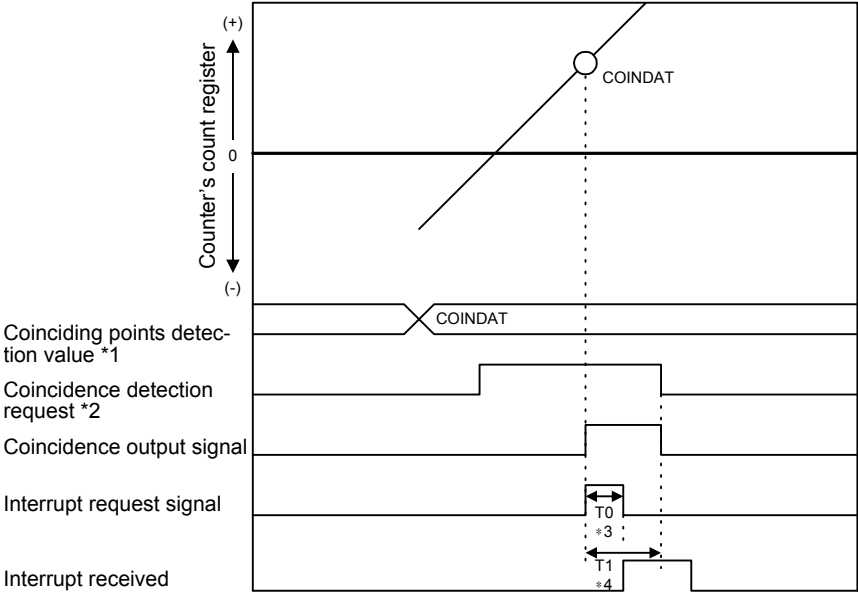

- * 1. Coinciding points detection value = Coincidence detection set value (IL0004)
- * 2. Coincidence detection request = Operating mode (OW0002, bit 3)
- * 3. T0: The maximum time (70 to 120 ms) from when the CPU Module receives the INT signal until the interrupt processing is started.
- * 4. T1: The time from when the interrupt request signal is received until DWG.I (interrupt drawing) execution is started.

When communications program is executed.:	Approx. 90 to 170 ms
When direct I/O command is executed.:	Approx. 90 to (1,460 + 40 + N) ms
N	Number of direct I/O words (8 max.)

4.4.7 PI Latch Function

The PI latch function stores (i.e., latches) in a memory register the current position at the moment an external signal is input (detected on the rising edge).

Select a special discrete input (PI input) as the external signal.

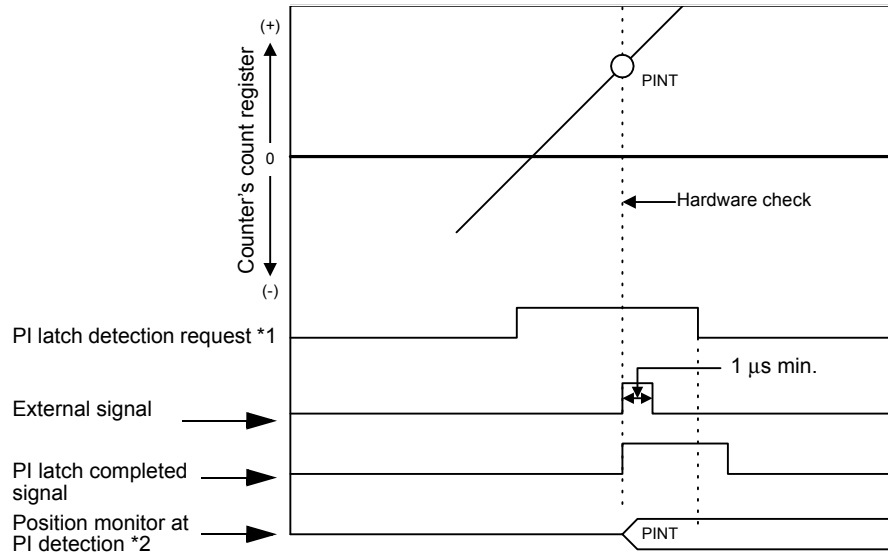

* 1. PI latch detection request = Operating mode (OW0002, bit 2)

* 2. PI detection position monitor = PI latch data (IL0006)

4.4.8 Electronic Gear

The electronic gear function enables the motor travel distance per input reference pulse to be set to any value. It allows the host controller to perform control without having to consider the machine gear ratio and the number of encoder pulses.

When Electric Gear Function is Not Used:

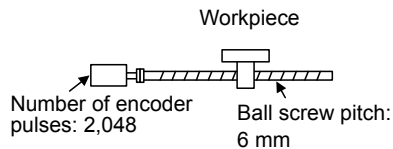

When Electric Gear Function is Used:

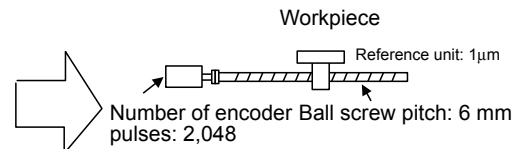

Machine conditions and reference unit must be defined for the electronic gear function beforehand.

To move a workpiece 10 mm:

One revolution is equivalent to 6 mm, so
 $10 \div 6 = 1.6666$ (revolutions)
 2048 x 4 (pulses) is equivalent to one revolution, so
 $1.6666 \times 2,048 \times 4 = 13,653$ (pulses)
 A total of 13653 pulses must be input as a reference.

The host controller needs to make this calculation.

To move a workpiece 10 mm:

Reference unit is $1 \mu\text{m}$, so
 $10 \text{ mm} \div 1 \mu\text{m} = 10,000$ pulses

■ Setting the Electronic Gear

Use the following procedure (steps 1 to 6) to set the electronic gear.

1. Check the machine specifications.

Items related to electronic gear:

- Gear ratio
- Ball screw pitch
- Pulley diameter, etc.

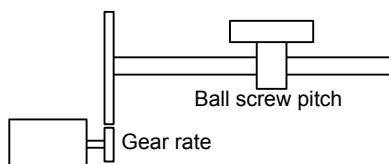

2. Check the number of encoder pulses input to the Counter, and set the number in fixed parameter 9 (Pulse number per one cycle of the encoder).
3. Determine the reference unit to be used.

A reference unit is the minimum unit of position data used for moving the load (Minimum unit of reference from the host controller).

To move a table in units of 0.001 mm:

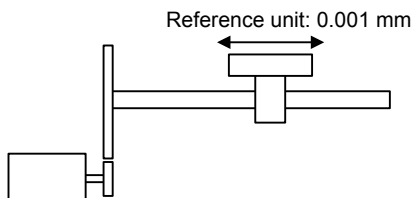

Determine the reference unit according to machine specifications and positioning accuracy.

◀EXAMPLE▶

- One pulse of a reference input of 0.01 mm, 0.001 mm, 0.1° , or 0.01 inch moves the load by one reference unit.
 - When reference unit is 1 μm:
If a reference of 50,000 pulses is input, the load moves 50 mm (50,000 x 1 μm).
4. Determine the load travel distance per revolution of load shaft in reference units.

$$\text{Load travel distance per revolution of load shaft (in reference units)} = \frac{\text{Load travel distance per revolution of load shaft (in unit of distance)}}{\text{Reference unit}}$$

◀EXAMPLE▶

- When ball screw pitch is 5 mm and reference unit is 0.001 mm:

$$\frac{5}{0.001} = 5,000 \text{ (reference units)}$$

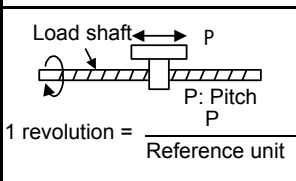
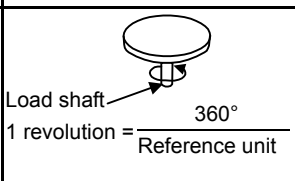
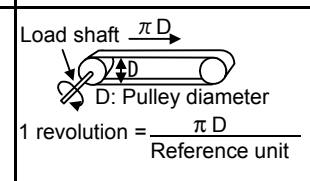
Ball Screw	Disc Table	Belt & Pulley
 <p>1 revolution = $\frac{P}{\text{Reference unit}}$</p>	 <p>1 revolution = $\frac{360^\circ}{\text{Reference unit}}$</p>	 <p>1 revolution = $\frac{\pi D}{\text{Reference unit}}$</p>

5. Set the gear ratio at the encoder and at the machine.

- No. 10 setting range: 1 to $2^{31}-1$ (1 = 1 reference unit)

◀EXAMPLE▶

- The load travel distance per revolution of load shaft = 12 mm

When minimum reference unit = 0.001 mm (reference unit: mm; digits below decimal point: 3), set as follows:

$$\text{No. 10} = \frac{12\text{mm}}{0.001\text{mm}} = 12,000$$

- When configured for motor shaft to rotate m times, and for load shaft to rotate n times, set the values as follows:

$$\left. \begin{array}{l} \text{No. 11} = m \text{ rotations} \\ \text{No. 12} = n \text{ rotations} \end{array} \right\}$$

Setting range: 1 to 65,535 (revolutions)

- When configured as follows:

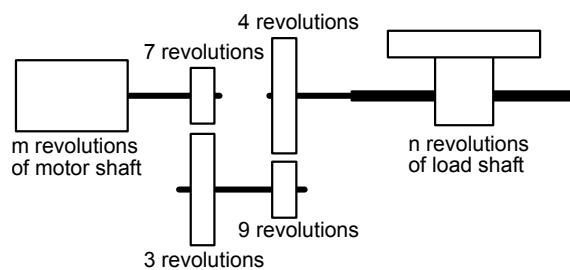

$$\text{Deceleration rate} = \frac{n}{m} = \frac{3}{7} \times \frac{4}{9} = \frac{4}{21}$$

Therefore set the following: $\left. \begin{array}{l} \text{No. 11} = 21 \\ \text{No. 12} = 4 \end{array} \right\}$

■ Electronic Gear Setting Example

The following example shows settings for various load mechanisms.

Electronic Gear Parameter Settings Example (A): Ball Screw

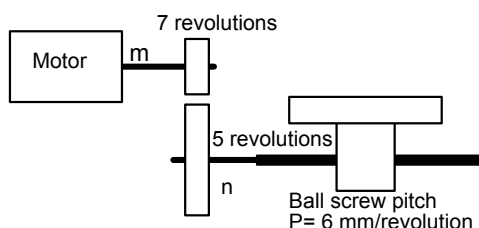

In the above mechanical system, to set reference unit = output unit = 0.001 mm, the set values for each parameter are as follows:

- No. 10 = $\frac{6\text{mm}}{0.001\text{mm}} = \mathbf{6000}$
- Gear ratio = $\frac{n}{m} = \frac{5}{7}$
- No.11 = 7
- No.12 = 5

4

Gear Parameter Settings Example (B): Rotational Load

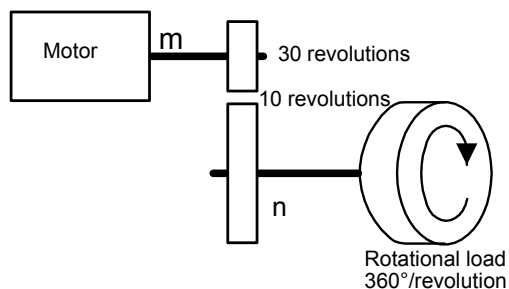

In the above mechanical system, to set reference unit = output unit = 0.1° , the set values for each parameter are as follows:

- No. 10 = $\frac{360^\circ}{0.1^\circ} = \mathbf{3600}$
- Gear ratio = $\frac{n}{m} = \frac{10}{30} = \frac{1}{3}$
- No.11 = 3
- No.12 = 1

4.4.9 Opening the Counter Module Definition Window

Open the Counter Module Definition Window from the Module Configuration Definition Window. Refer to the sections on opening individual Module Definition Windows.

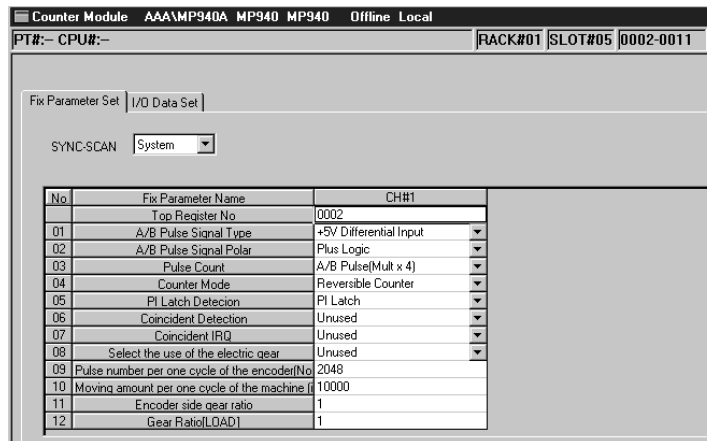

■ Configuration Information

The Counter Module configuration information is displayed in the upper part of the definition screen. Set the configuration information using the Counter Module Configuration Definition Window.

Configuration Information	Details
PT number	The logic port number of the Programming Device
CPU number	The control CPU number
Rack number	Displays the virtual rack number defined in the Counter Module.
Slot number	Displays the virtual slot number defined in the Counter Module.
Register range	Displays the I/O register range allocated in the Counter Module.

■ Tab Windows

The Counter I/O Definition Window has two tab controls, Fixed Parameter Settings and I/O Data Settings.

Tab Window Name	Function
Fixed Parameter Settings	Sets the Counter fixed parameters.
I/O Data Settings	Sets the Counter I/O data.



When you open the Counter I/O Definitions Window without any settings having been made, the Create New Message Box will be displayed. Click the **OK** Button, and then proceed to the next operation.

4.4.10 Defining Counter I/O

■ Setting Fixed Parameters

Setting Synchronous Scans

Select System, High, or Low from the scan box.

Fixed Parameter Settings Table

No	Setting Item	Details	Default Setting
	Leading register number (See note.)	Leading address of the I/O register to use	2
1	A/B pulse signal form selection	Fixed to 5-V differential input	
2	A/B pulse signal polarity selection	Specifies A/B pulse polarity: Positive (0) or negative (1)	0
3	Pulse count method selection	0 Sign mode, x1 1 Sign mode, x2 2 Up/Down mode, x1 3 Up/Down mode, x2 4 A/B pulse mode, x1 5 A/B pulse mode, x2 6 A/B pulse mode, x4	6
4	Counter mode selection	Fixed to reversible counter	
5	PI latch detection signal selection	Fixed PI latch	
6	Coincidence detection function use selection	Specifies whether the coincidence detection function is OFF (0) or ON (1)	0
7	Coincidence interrupt function use selection	Specifies whether the coincidence interrupt function is OFF (0) or ON (1). Valid only when the coincidence detection function only is ON (1)	0
8	Electronic gear use selection	Specifies whether the electronic gear is OFF (0) or ON (1)	0
9	Number of pulses per encoder revolution	1 to 65535	2048
10	Travel distance per machine revolution	1 to $2^{31}-1$	10000
11	Encoder gear ratio	1 to 65535	1
12	Machine gear ratio	1 to 65535	1

Note: You can set the leading register number on the Module Configuration Definition Screen. The default setting is 2.

4.4.11 Setting I/O Data

Click the *I/O Data Settings* Tab.

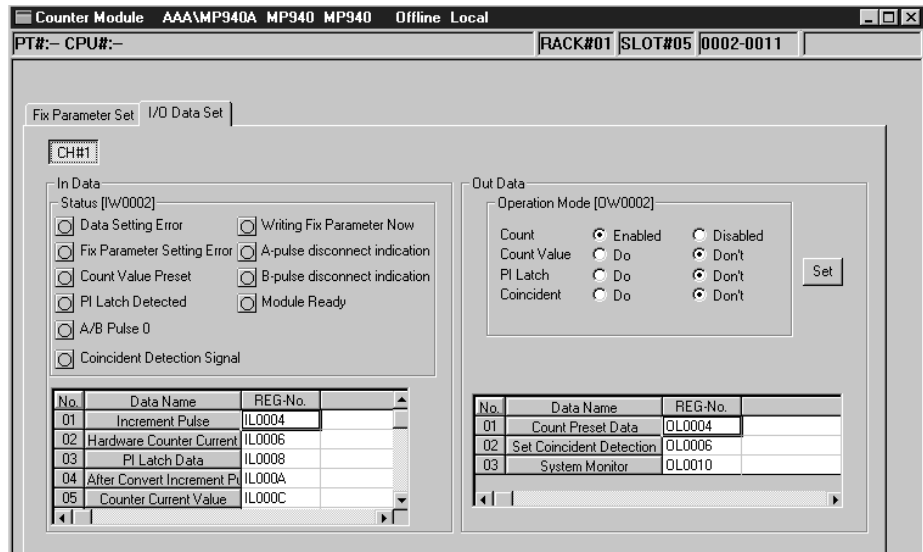

Channel Number

The channel number is always displayed as CH#1.

Input Data

- Operating Status (IW0002)

The status of each bit in the operation status register is displayed as either ON or OFF . The leading input register is the status word.

Bit No.	Status Name	Meaning
0	Data Setting Error	ON: Data setting error has occurred.
1	Fix Parameter Setting Error	ON: Fixed parameter setting error has occurred.
2	Count Value Preset	ON: Count has been preset.
3	PI Latch Detected	ON: PI latch has been completed.
4	A/B Pulse 0	ON: Feedback pulse is ± 1 max.
5	Coincident Detection Signal	ON: Coincidence detection signal is ON (Unit: pulse)
6 to 8	Not used	---
9	Writing Fix Parameter Now	ON: Writing online parameters
10	A-pulse Disconnect Indication	ON: Pulse disconnected
11	B-pulse Disconnect Indication	ON: Pulse disconnected
12 to 14	Not used	
15	Module Ready	ON: Counter Module ready

- Input Data Settings

Setting Item	Register	Range	Meaning
Number of incremental pulses	IL0004	-2147483648 to 2147483647	1 = 1 pulse Number of pulses within 1 scan
Hardware counter current value	IL0006	-2147483648 to 2147483647	1 = 1 pulse Counter's unprocessed data
PI latch data	IL0008	-2147483648 to 2147483647	1 = 1 pulse Counter value at latch detection
Number of incremental pulses after conversion	IL000A	-2147483648 to 2147483647	1 = 1 reference unit Converted to reference units when electronic gear is enabled. No communications when electronic gear is disabled.
Counter current value	IL000C	-2147483648 to 2147483647	1 = 1 reference unit Counter when electronic gear is enabled.
PI latch data after conversion	IL000E	-2147483648 to 2147483647	1 = 1 reference unit
System monitor	IL0010	-2147483648 to 2147483647	Reserved for system use

Output Data

4

- Operating Mode (OW0002)

The status of each bit in the operating mode register is displayed. Select the display using the option buttons.

Bit No.	Command Name	Meaning
0	Count enabled	Prohibited/enabled
1	Count value preset	ON/OFF
2	Request PI latch detection	ON/OFF
3	Request coincidence detection	ON/OFF

- Output Data Settings

Setting Item	Register	Range	Meaning
Count preset data	OL0004	-2147483648 to 2147483647	1 = 1 pulse 1 = 1 reference unit
Coincidence detection setting	OL0006	-2147483648 to 2147483647	1 = 1 pulse 1 = 1 reference unit

Note: The register uses the default address. You can set the register address using the Module Configuration Definition Screen.

4.4.12 Saving Counter I/O Definition Data

Use the following procedure to save counter I/O definition data. In Online Mode, the data is saved to both the Machine Controller and hard disk, and in Offline Mode, the data is saved to the hard disk only.

Use the following procedure to save counter I/O definition data.

1. Select **File (F)** and then **Save (S)** from the Counter I/O Definition menus.
2. Click the **Yes (Y)** Button in the message box.
3. Click the **OK** Button in the message box.

4.4.13 Deleting Counter I/O Definition Data

All the counter I/O definition data can be deleted. In Online Mode, the data is deleted from both the Machine Controller and hard disk, and in Offline Mode, the data is deleted from the hard disk only.

Use the following procedure to delete counter I/O definition data.

1. Select **File (F)** and then **Delete (D)** from the Counter I/O Definition menus.
2. Click the **Yes (Y)** Button in the message box.
3. Click the **OK** Button in the message box.

4.5 MECHATROLINK Functions

This section explains the MP940 (JPMC-MC400) high-speed field network communications using MECHATROLINK.

4.5.1 MECHATROLINK Overview

An example of a network-compatible I/O Module connection to the MP940 Machine Controller using high-speed field network communications is given below as an overview of MECHATROLINK (MLINK).

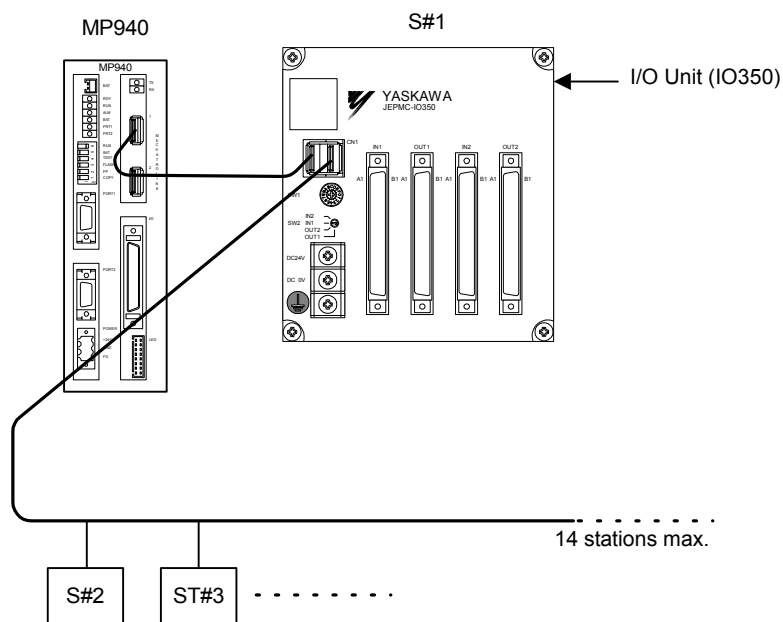

Fig 4.1 MLINK Connection Example

In this example, a Remote I/O Module is connected as station 1 and MECHATROLINK I/O devices are connected from the station 2 onward.

4.5.2 MECHATROLINK Communications Specifications

The MECHATROLINK communications specifications for the MP940 are as follows:

No.	Item	Specifications
1	Communications path type	Bus type
2	Communications path	Electric bus
3	Baud rate	4 Mbps
4	Communications cycle	1 ms, 2 ms, 4 ms
5	Number of connectable stations	14 stations max.

No.	Item	Specifications
6	Communications control method	Cyclic
7	Data conversion	1:N
8	Communications mode	Control communications
9	Error control	CRC check, number of data words check, timer

4.5.3 Master and Slaves

You can select whether to use the MP940 as a master or as a slave.

An example of master-slave connections is shown below.

■ Using the MP940 as a Master

Connection Example

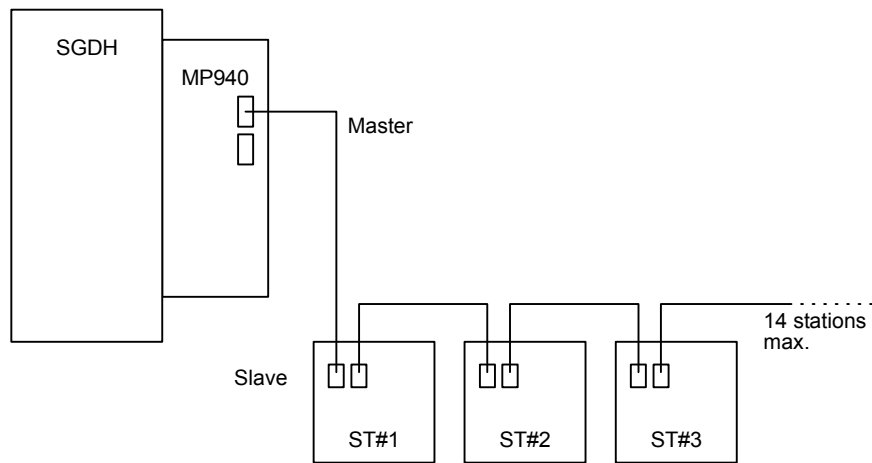

Connectable Slave

The following table shows the slaves that can be connected to the MP940 selected as the master.

Slave Module Type	Name	Model Number
Digital I/O Modules	64-point I/O Module	JEPMC-IO350
	Wide-voltage 8-point Output Module	JAMSC-120DRA83030
	100-VAC 8-point Input Module	JAMSC-120DAI53330
	200-VAC 8-point Input Module	JAMSC-120DAI73330
	12/24-VDC 16-point Input Module	JAMSC-120DDI34330
	12/24-VDC 16-point Output Module	JAMSC-120DDO34340
	100/200-VAC 8-point Output Module	JAMSC-120DAO83330
Analog I/O Modules	Analog ± 10 V Input Module	JAMSC-120AVI02030
	Analog ± 10 V Input Module	JAMSC-120AVO01030
PLC Module	MP940	JEPMC-MC400



Set the scan using SCAN in the Parameter Settings Tab Page in the MECHATROLINK Definition Window. Individual settings are not possible.

IMPORTANT

Only simple I/O is supported by the MP940 MECHATROLINK. You cannot connect a MECHATROLINK Servo or 216IF Inverter.

Control Data Configurations

The data configurations used in data communications with slaves are shown below.

- JEPMC-IO350 (64-point I/O)

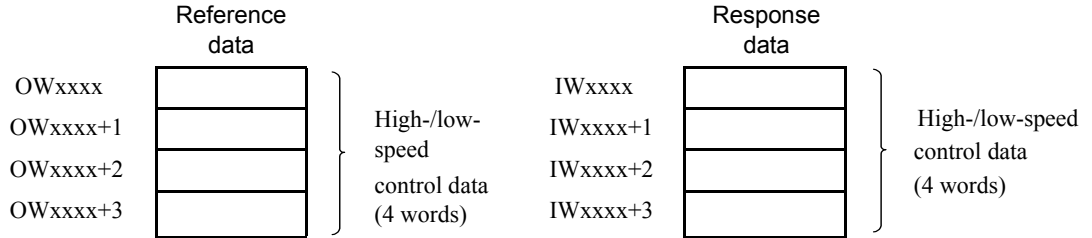

- 120DAI53330 (8-point Input)



- 120DAI73330 (8-point Input)



- 120DDI34330 (16-point Input)



- 120DDO34340 (16-point Output)

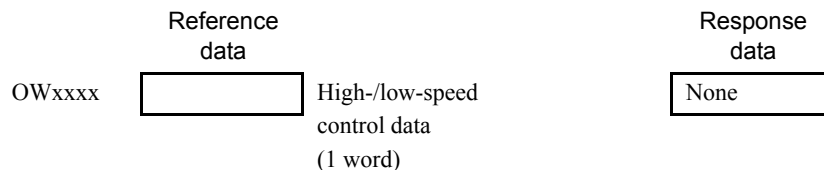

- 120DAO83330 (8-point Output)

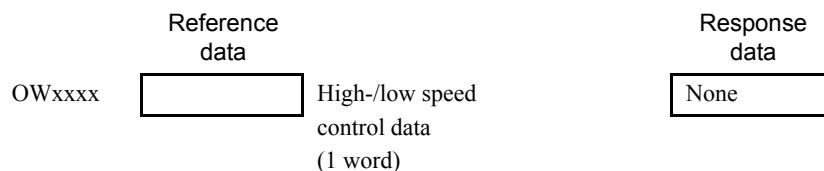

• 120DRA83030 (8-point Output)

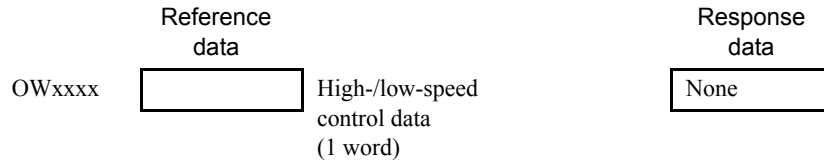

• 120AVI02030 (Analog Input)

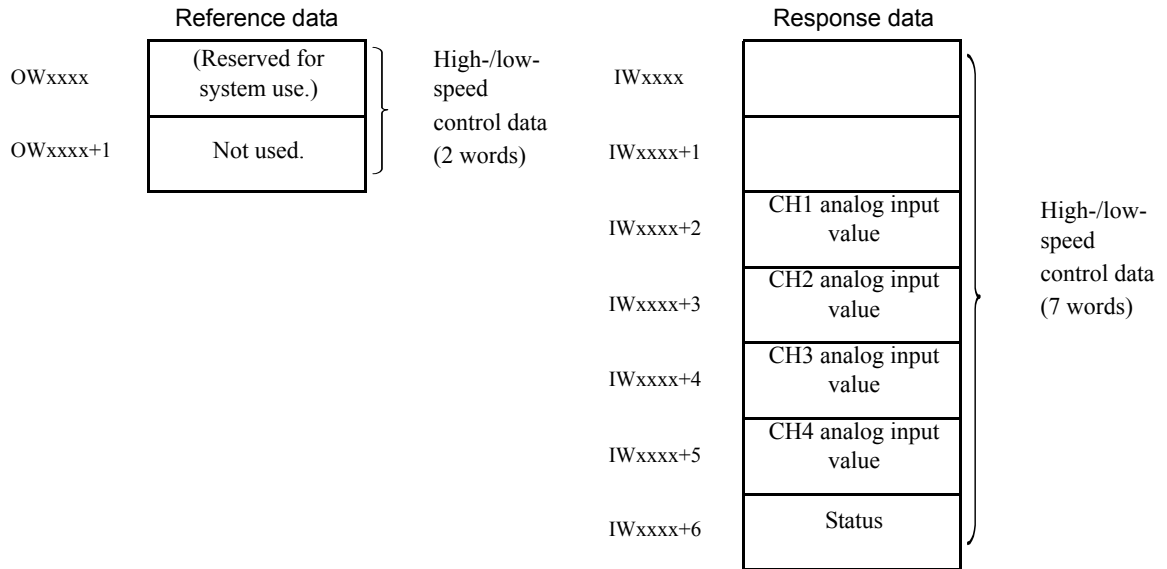

• 120AVO01030 (Analog Output)

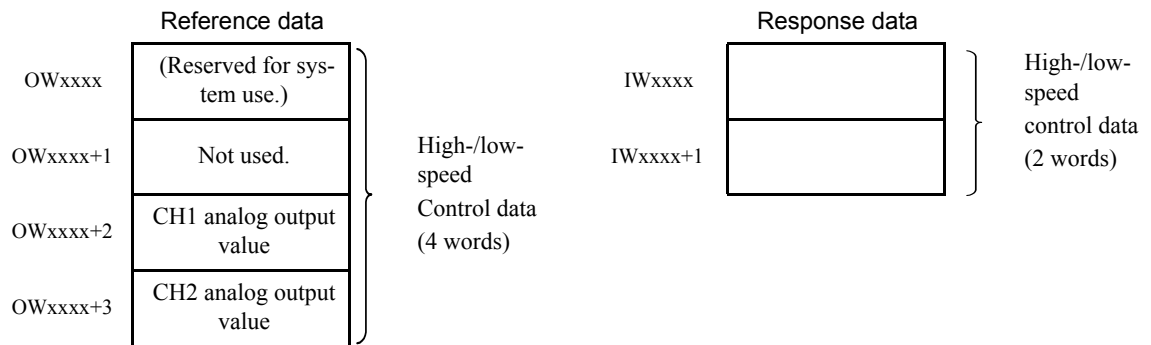

• MP940 (Machine Controller)

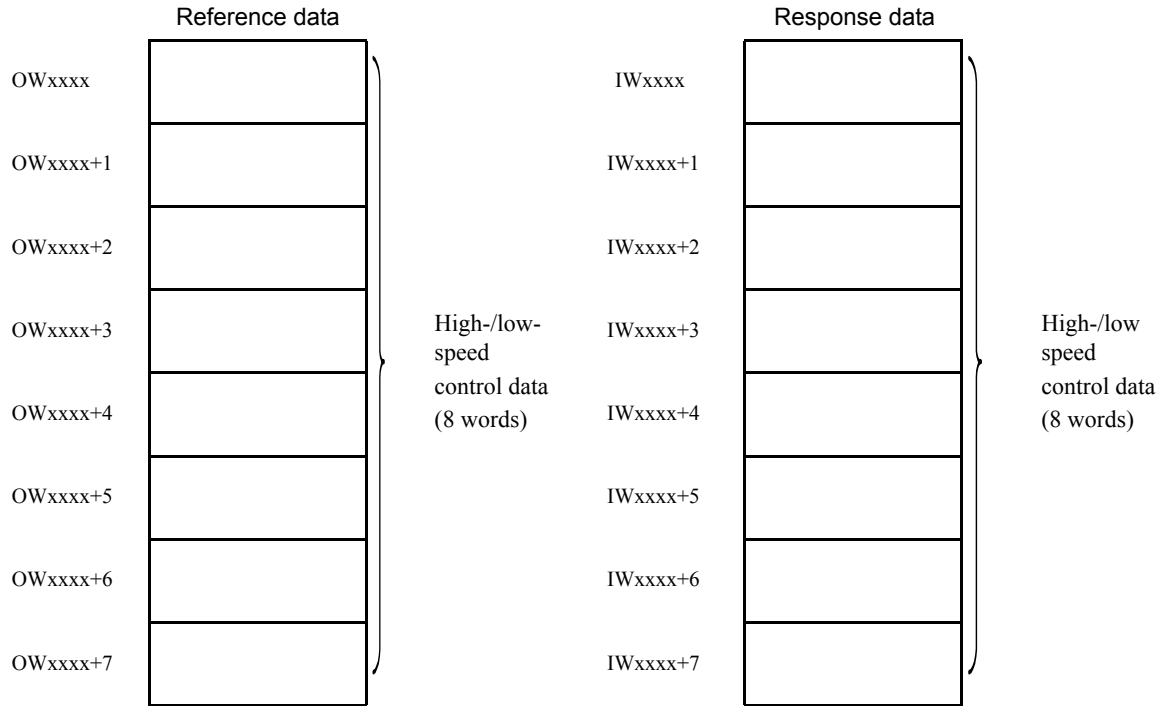

■ Using the MP940 as a Slave

Connection Example

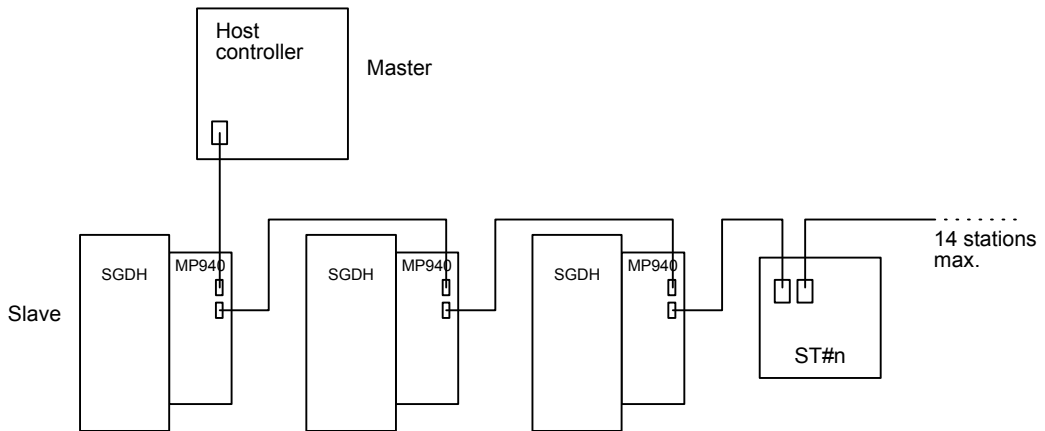

IMPORTANT

When the MP940 is selected as a Slave, you cannot connect IO350 Units or distributed I/O to the MP940.

4.5.4 MECHATROLINK Connections

The following example shows I/O350 Units connected to an MP940 Module.

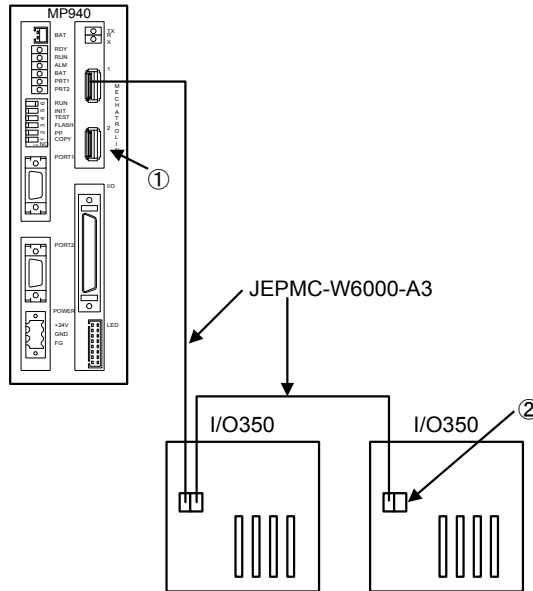

When connecting an MP940 Module to an IO350 Unit, or an IO350 Unit to an IO350 Unit, use a JEPMC-W6000-A3 Standard Cable.

IMPORTANT

Always insert a JEPMC-W6020 USB Terminator into the connector terminals (1. and 2. in the above diagram). Refer to the section on cables for appearance and internal connection diagrams.

The connectors for MECHATROLINK 1 and MECHATROLINK 2 are the same. Insert a JEPMC-W6020 USB Terminator into unused ports.

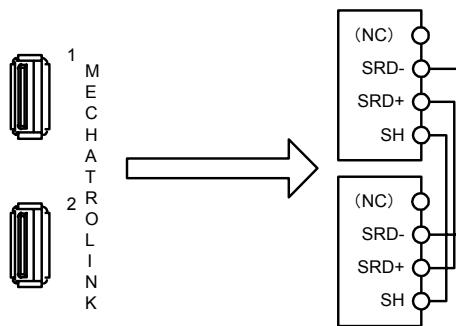

IMPORTANT

Only a single MECHATROLINK port channel can be used on the MP940 Module. There are two connector ports, but as the above diagram shows, they are both the same.

4.5.5 Opening the MECHATROLINK Window

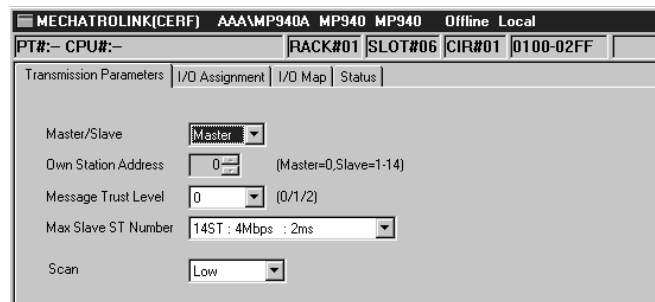

The MECHATROLINK Definition Window is opened from the Module Configuration Definition Window.

The window as it appears immediately after opening is shown above.

■ Configuration Information

Details of the MECHATROLINK configuration information, which is set using the Module Configuration Definition Window, are displayed under the window title.

Configuration Information	Details
PT #	The number of the logical port in use is displayed when online.
CPU #	The number of the logged-in CPU Unit is displayed when online.
Rack number	The rack number defined using MECHATROLINK is displayed.
Slot number	The slot number defined using MECHATROLINK is displayed.
Circuit number	The MECHATROLINK circuit number is displayed.
Register range	The I/O register range is displayed.

■ Tab Windows

Set the devices connected to the MECHATROLINK network. The settings are separated into four tab windows depending on the type of setting.

Tab Window	Details
Transmission Parameters	Sets the basic MECHATROLINK communications parameters.
I/O Assignment	Used to allocate I/O devices and registers in MECHATROLINK.
I/O Map	Used to allocate the detailed I/O map.
Status	Displays the communications status.



When you open the MECHATROLINK Definition Window before any settings have been made, a message box indicating that new settings are being created will be displayed. Click the **OK** Button, and then perform the following settings.

4.5.6 Setting MECHATROLINK Definitions

This section explains the setting items for tab windows.

■ Transmission Parameters Tab Window

Set the parameters necessary to use MECHATROLINK communications.

Setting Item	Details	Default Setting
Master/Slave	Set whether to use the Machine Controller as a Master or a Slave. Turn the power supply OFF and then ON again to enable the settings.	Master
Own Station Address	If using the local station as the master, the local station address is set to 0. If the station is a slave, set the station address from 1 to 29.	0
Message Trust Level	Not used, because there are no message communications.	0
Maximum Slaves ST Number	There are three levels for the maximum number of Slaves. Refer to the Number of Slaves Table, and then select the details corresponding to the scale of the number of Slaves.	14
Scan	Specify High or Low.	Low

Table 4.9 Number of Slaves Table

Number of Slaves	Baud Rate	Communications Cycle
14	4 Mbps	2 ms

■ I/O Assignment Tab Window

ST#	TYPE	D	INPUT	SIZE	D	OUTPUT	SIZE	SCAN	St#
01	JEPMC-10350		Iw0100	4		Ow0110	4	Low	
02									
03									
04									
05									
06									
07									
08									
09									
10									
11									
12									
13									

Set the I/O devices and registers connected to MECHATROLINK using the I/O Assignment Tab.

Setting Item	Details
ST #	Displays the station number. You can set a maximum of 14 stations.
TYPE	Set the I/O device connected to each station. Select the type from the drop-down list.
D	Sets the disable status of the input register.
INPUT, SIZE	Set the leading input register address. The number of registers is set automatically. Make sure that the registers do not overlap with other stations. The register addresses that can be set are determined by the range set using the leading and end I/O register addresses in the Module configuration definitions.
D	Set the I/O register disable condition.
OUTPUT, SIZE	Set the leading output register address. The number of registers is set automatically. Make sure that the register range does not overlap with other stations. The register addresses that can be set are determined by the range set using the leading and end I/O register addresses in the Module configuration definitions.
SCAN	Sets the scan for servicing I/O. The scan set in the Transmission Parameters Window is set automatically.
Station Name	Enter a comment for the station to 32 characters max.

Table 4.10 I/O Device List

Slave Module Type	Name	Model
Digital I/O Modules	64-point I/O Module	JEPMC-IO350
	Wide-voltage 8-point Output Module	120DRA83030
	100-VAC 8-point Input Module	120DAI53330
	200-VAC 8-point Input Module	120DAI73330
	12/24-VDC 16-point Input Module	120DDI34330
	12/24-VDC 16-point Output Module	120DDO34340
	Wildcard I/O Module	
	100/200-VAC 8-point Output Module	120DAO83330
Analog I/O Module	Analog ± 10 V Input Module	120AVI02030
	Analog ± 10 V Output Module	120AVO01030
PLC Module	MP940 Module	JEPMC-MC400

Table 4.11 Enable/Disable Conditions

Icon	I/O State
<input type="checkbox"/>	Enabled
<input checked="" type="checkbox"/>	Disabled

■ Deleting Allocated Data

1. Position the cursor on the line for the station you want to delete, and select **Delete Allocation (A)** from the **Edit (E)** Menu.
2. The data allocated to the station will be deleted.

■ I/O Map Tab Window

The I/O Map Tab Window displays the I/O allocation status for the Machine Controller.

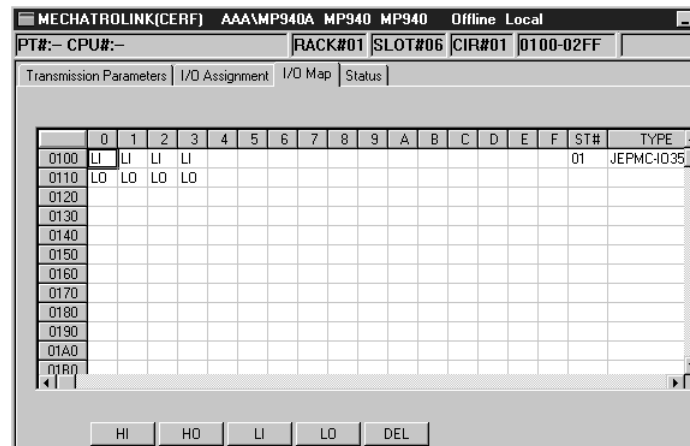

SCAN	Meaning
HI	Allocated as high-speed scan input.
HO	Allocated as high-speed scan output.
LI	Allocated as low-speed scan input.
LO	Allocated as low-speed scan output.
DEL	Deletes allocation.

■ Status Tab Window

The Status Tab Window displays the communications status for each station.

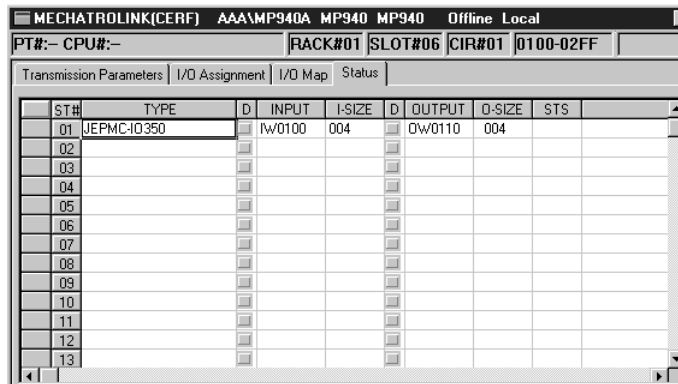

You can only display the status on the Status Tab Window; settings cannot be changed.

The meaning of the items is the same as the I/O Assignment Tab Window, with only the STS column added.

STS

In Online Mode, the details of the MECHATROLINK communications status is displayed in hexadecimal. Nothing is displayed in Offline Mode.

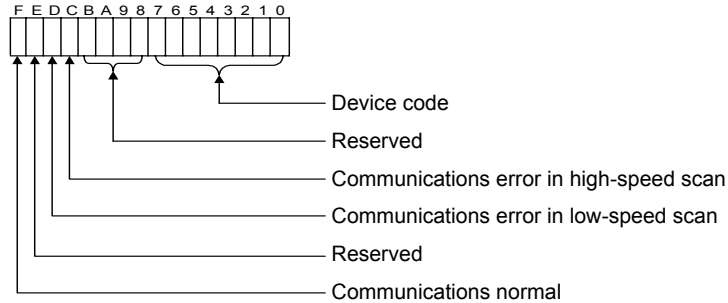

4.5.7 Saving MECHATROLINK Definitions

Use the following procedure to save MECHATROLINK definition data.

1. Select **Save (S)** from the **File (F)** Menu.
2. Click the **Yes (Y)** Button in the message box to save the definition data.

4.5.8 Deleting MECHATROLINK Definitions

Use the following procedure to delete MECHATROLINK definition data.

1. Select **Delete (D)** from the **File (F)** Menu.
2. Click the **Yes (Y)** Button in the message box to delete the definition data.

4.5.9 Ending MECHATROLINK Definitions

Select **Close (C)** from the **File (F)** Menu.

4.6 DeviceNet Functions

DeviceNet is a multivendor field network whose specifications are managed by ODVA (Open DeviceNet Vendor Association, Inc). The MP940D connects to a multivendor DeviceNet system, and operates as a DeviceNet master or slave.

For details on DeviceNet, refer to the DeviceNet specifications published by ODVA.

4.6.1 System Configuration

The MP940D is a communications interface for connecting the MP940 to the DeviceNet. The MP940D can be connected to DeviceNet as a slave. An example of system configuration is shown below.

■ DeviceNet System Configuration Example

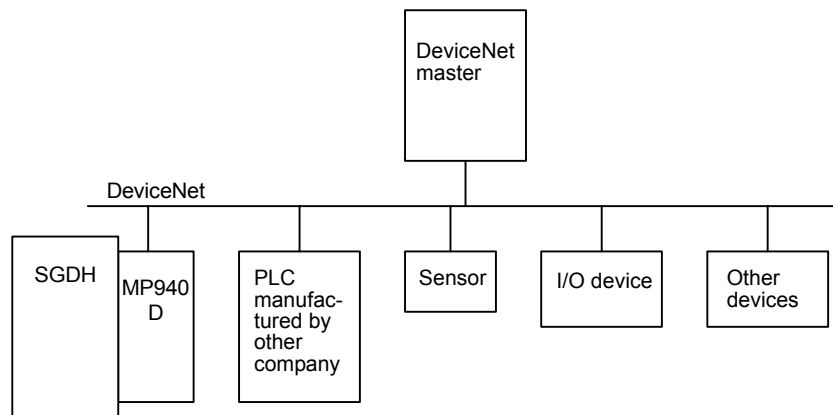

■ MP940D Wiring Example

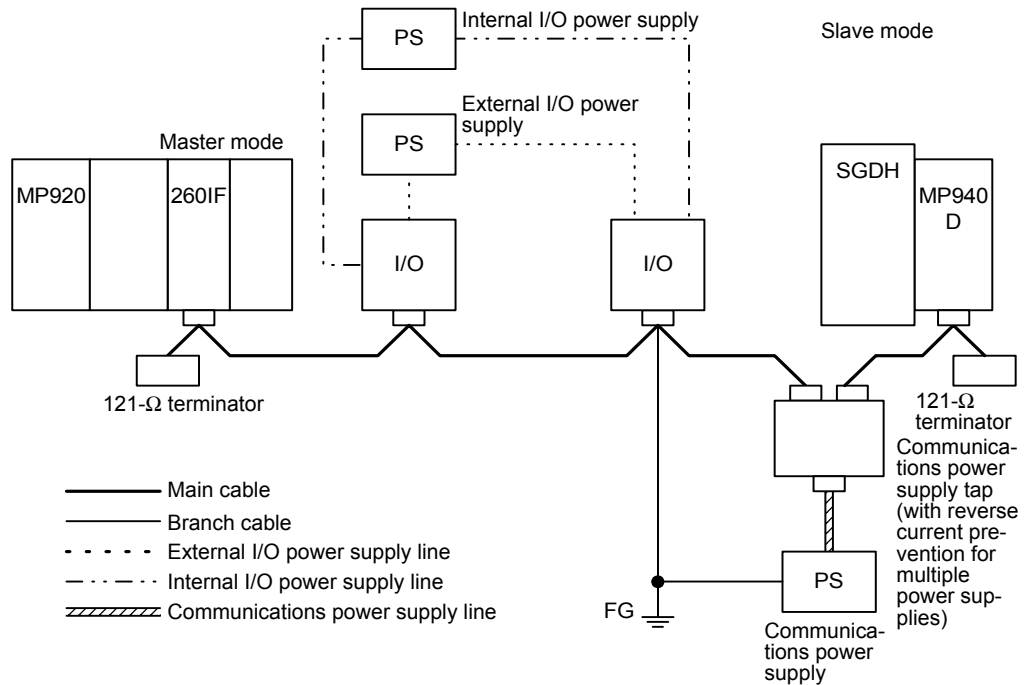

4.6.2 I/O Communications Function

I/O communications exchange I/O data between the MP940D and the DeviceNet over the communications path via DeviceNet I/O connections. I/O registers for I/O communications are allocated in the controller CPU using the CP-717.

4.6.3 Communications Specifications

The following table shows the basic MP940D specifications by Interface Module.

Item		Specification
Name		MP940D
Model Number		JEPMC-MC410
Number of circuits		1
Compatible Communications		I/O communications function (conforming to DeviceNet)
I/O Communications	Maximum Number of Slaves	63 nodes
	Maximum Number of I/O Bytes	2,048 bytes with 256 bytes per node
Setting Locations	2 Rotary Switches on Side of Module	Node address
	DIP Switch on Side of Module	Baud rate and master/slave setting
Indicators		2 LED indicators: MS and NS
Communications Power Supply Voltage		24 VDC ±10% (supplied by special cable)

4.6.4 260IF Module Setup

The 260IF Module is set up from the CP-717 Engineering Tool.

■ Opening the 260IF Configuration Window

Use the following procedure to open the 260IF Configuration Window.

1. Double-click the Module Configuration Definition Box for the Controller mounted to the 260IF Module to display the Module Configuration Window.

No.	00	01	02
Module	MP940 ▼	RESERVED	260IF ▼
Control CPU No.			
·	·	·	·
·	·	·	·
Leading I/O register	·	·	·
End I/O register	·	·	·
·	·	·	·

Fig 4.2 MP920 Module Configuration Window

No.	00	01	02	03	04	05	06
Module	MP940 ▼	RESERVED	SERIAL	LIO	SVA	CNTR	260IF ▼
Control CPU No.							
·	·	·	·	·	·	·	·
·	·	·	·	·	·	·	·
Leading I/O register	·	·	·	·	·	·	·
End I/O register	·	·	·	·	·	·	·
·	·	·	·	·	·	·	·

Fig 4.3 MP940 Module Configuration Window

For the MP940, the 260IF is always in slot 06, but 260IF must still be set.

The leading and end I/O register numbers must be set for the 260IF Module. Allocate I/O registers within the ranges shown in the following table.

Leading I/O register (Offset of leading IW/OW register)	0000 to 07FF
End I/O register (Offset of end IW/OW register)	0000 to 07FF

2. Double-click the slot where the 260IF is set and open the 260IF Configuration Window.

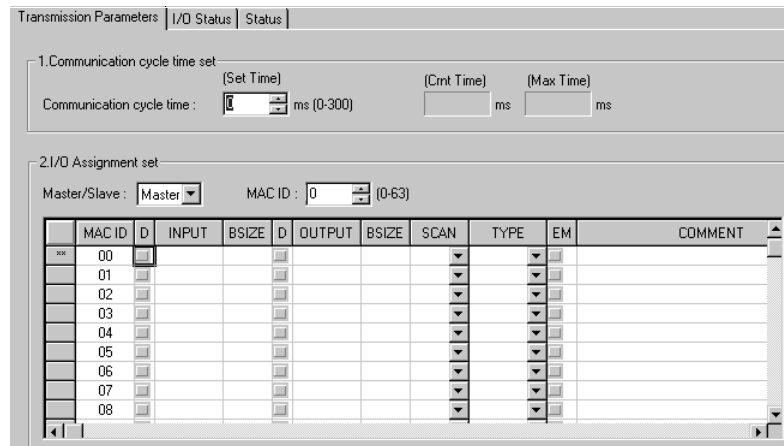
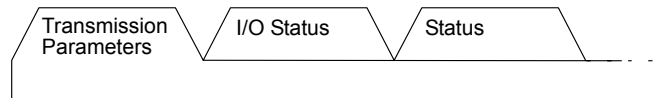

Fig 4.4 260IF Configuration Window

■ Setting Methods

The 260IF Configuration Window has the following three tab pages.



Tab Page	Contents
Transmission Parameters	Set the 260IF Module communications and network parameters.
I/O Status	Displays the communications status with Slaves when the 260IF Module is set to Master Mode and is online.
Status	Shows the 260IF Module status when online.

Parameter Settings

The following items are set in the Transmission Parameter Tab Page of the 260IF Configuration Window.

- Communications Cycle Time Information

Setting	Contents
Communications Cycle Time (set value)	Enter the communications cycle time set value when using the 260IF as a DeviceNet Master.
Communications Cycle Time (current value) display only	Open during I/O communications to display the current value of the communications cycle.
Communications Cycle Time (max. value) display only	Open during I/O communications to display the maximum value for the communications cycle.

Refer to 4.2 *Calculating Communications Cycle Times* in MP920 User's Manual 260IF DeviceNet (SIEZ-C887-5.2).

- I/O Allocations

The asterisks (**) displayed on the left in the I/O allocations table indicate the 260IF allocations in the Module Configuration Window.

Setting	Contents															
Master/Slave	Set the operating mode (DeviceNet Master/Slave) for the 260IF Module. Set the same value as that set on SW1 (X1) on the 260IF Module.															
MAC ID	The DeviceNet MAC ID (DeviceNet address) for the 260IF Module. Set the same value as that set on SW2 and SW3 on the 260IF Module.															
MAC ID (column)	The DeviceNet MAC ID (DeviceNet address) for I/O allocations. It is automatically allocated in order starting from 00.															
D	Determines whether or not the Controller CPU exchanges I/O data with the 260IF. Turn ON (check) this setting if the data is not to be exchanged.															
INPUT	Sets the leading word address of the input area for the corresponding device input data (input register IWxxxx). Specify a hexadecimal address.															
BSIZE	Sets the size of the output area for the corresponding device (input register IWxxxx) in number of bytes. Specify a number of bytes between 1 and 256 (decimal) for each Slave. For example, if the setting is 3 bytes from IW1100 and one byte from IW1102, the register area shown in the following diagram will be allocated.															
	<table border="1" style="width: 100%; border-collapse: collapse;"> <thead> <tr> <th style="width: 33%;">Register No.</th> <th style="width: 33%;">F.....8</th> <th style="width: 33%;">7.....0</th> </tr> </thead> <tbody> <tr> <td>IW1100H</td> <td style="background-color: #cccccc;"></td> <td style="background-color: #cccccc;"></td> </tr> <tr> <td>IW1101H</td> <td></td> <td style="background-color: #cccccc;"></td> </tr> <tr> <td>IW1102H</td> <td></td> <td style="background-color: #cccccc;"></td> </tr> <tr> <td>IW1103H</td> <td></td> <td></td> </tr> </tbody> </table>	Register No.	F.....8	7.....0	IW1100H			IW1101H			IW1102H			IW1103H		
	Register No.	F.....8	7.....0													
	IW1100H															
	IW1101H															
IW1102H																
IW1103H																
D	Sets whether or not the Controller CPU will exchange I/O data with the 260IF. Turn ON (check) this setting if the I/O data is not to be exchanged.															
OUTPUT	Shows the first word address of the output area (output register OWxxxx) allocated to the corresponding device. Specify a hexadecimal address.															

Setting	Contents
BSIZE	Sets the size of the output area (output register OWxxxx) allocated to the corresponding device in number of bytes. Specify a number of bytes between 1 and 256 (decimal) for each Slave. The byte order is little-endian, the same as for input registers.
SCAN	The data exchange cycle (SCAN) is when the Controller CPU exchanges I/O data with the 260IF Module. The Controller CPU data exchange cycle is asynchronous with the I/O data. When set to “High,” the Controller CPU will exchange I/O data during the high-speed scan of the CPU. When set to “Low,” the Controller CPU will exchange I/O data during the low-speed scan of the CPU.
TYPE	Set the I/O communication type (TYPE) to either “Polled” or “Strobed.” <ul style="list-style-type: none"> • Polled means settings can be made for any DeviceNet device. • Strobed means settings can be made for inputs only and for DeviceNet Slaves 8 bytes or less in size. Refer to DeviceNet specifications for details on Polled and Strobed settings.
EM (Explicit Message)	EM is turned ON when the 260IF Card is set as a DeviceNet Master and only message communications are performed with Slaves. The EM allocation setting is not required when the 260IF Card is set as a DeviceNet Slave.
COMMENT	The name and type of the relevant device and other information can be input as a character string of up to 32 characters.

- Saving Parameters

Once the parameters have been set, select File (F) and then Save (S) from the menu to save the settings.

- Additional Explanation of I/O Allocation Settings

a) Master/Slave

Set the same value as that set on SW1 (X1) on the 260IF Module.

b) MAC ID

Set the same value as that set on SW2 and SW3 on the 260IF Module.

c) Communications Cycle Time

Enter the communications cycle time calculated in *4.2 Calculating Communications Cycle Times* in MP920 User’s Manual 260IF DeviceNet (SIEZ-C887-5.2).

This setting is not required when the 260IF is used as a DeviceNet Slave.

d) I/O Allocations

Allocate the I/O registers for data exchange between the Controller CPU and the 260IF Card according to the DeviceNet system configuration.

Transmission Parameters | I/O Status | Status

1. Communication cycle time set

(Set Time) (Cmt Time) (Max Time)

Communication cycle time : 0 ms (0-300) ms ms

2. I/O Assignment set

Master/Slave : Master MAC ID : 0 (0-63)

MAC ID	D	INPUT	BSIZE	D	OUTPUT	BSIZE	SCAN	TYPE	EM	COMMENT
** 00										
01										
02										
03										
04										
05										
06										
07										
08										

• Slave I/O Allocation Example

The settings shown in the following diagram are made when, for example, the 260IF Module is to be used as a DeviceNet Slave with MAC ID = 3 and input and output sizes of 64 bytes each and I/O data is to be exchanged with the DeviceNet Master.

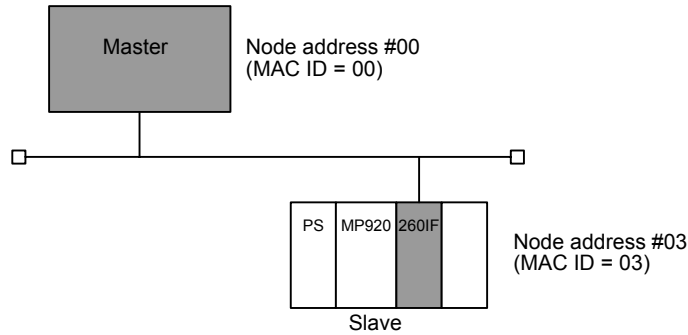

2. I/O allocation settings

Master/Slave: Slave MAC ID : 3

MAC ID	D	INPUT	BSIZE	D	OUTPUT	BSIZE	SCAN	TYPE	EM	COMMENTS
00										
01										
02										
03		IW1100	064		OW1200	064	High	Polled		Slave
...										
...										

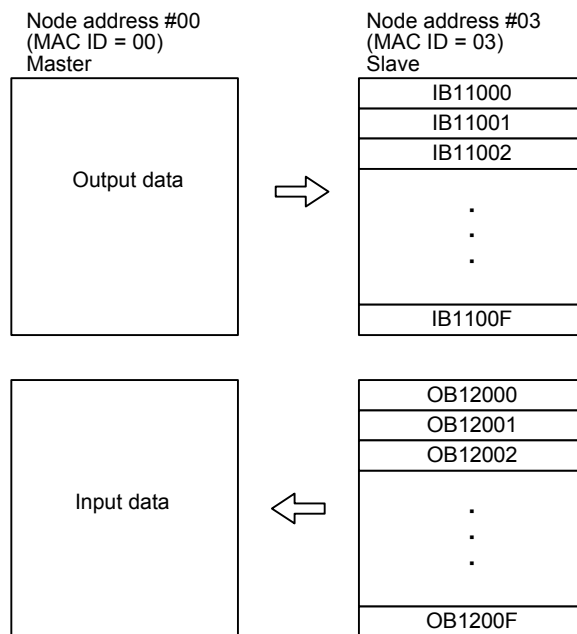

4.7 SVA Function

This section explains the SVA function.

4.7.1 Overview

The MP940 Module uses a bus connection to an SGDH SERVOPACK servo connector, and controls one servo axis via shared memory.

Consequently, to control the SGDH SERVOPACK, the MP940 Module exchanges data, such as speed control, encoder pulse inputs, etc., via shared memory instead of using analog voltages, as was previously done.

4.7.2 Separate and One-unit Systems

■ Separate Systems

In a separate system, the Controller and SERVOPACK are connected using a special cable to control the analog voltage output, and the encoder pulse and other information is fed back.

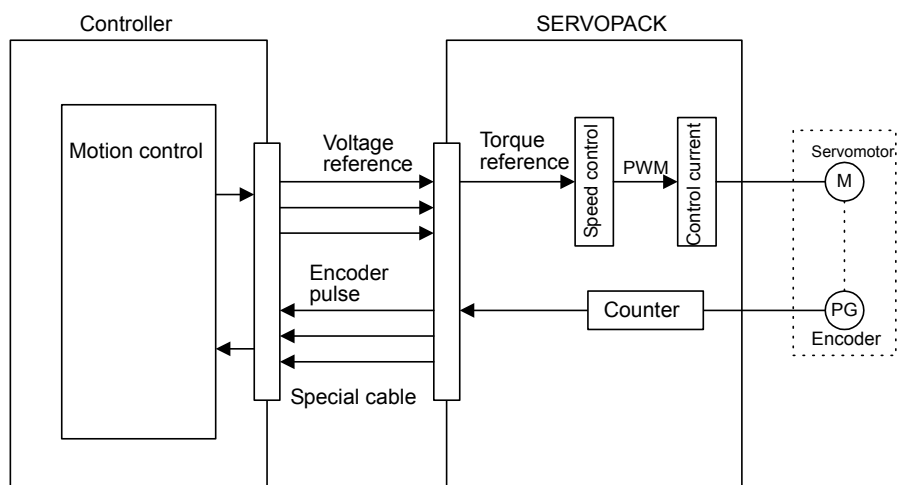

■ One-unit System

The Controller and SERVOPACK exchange commands and feedback data via shared memory by merging the bus.

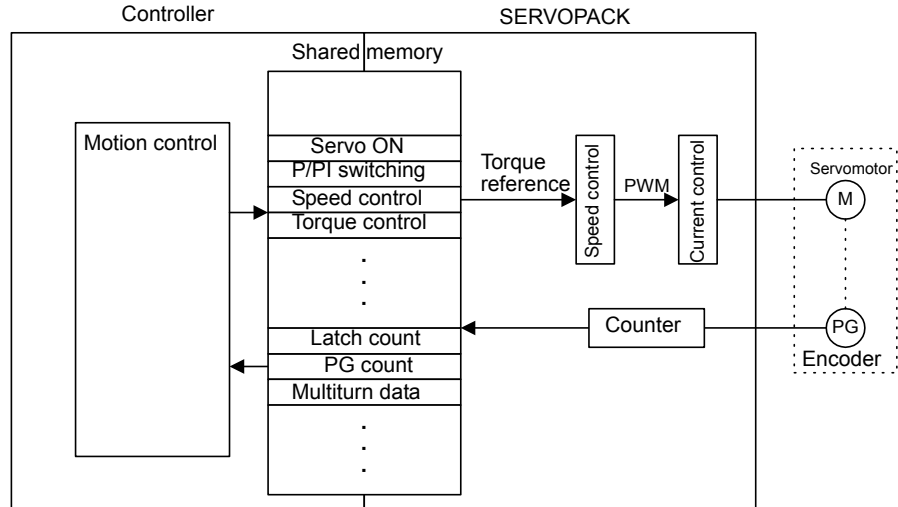

4.7.3 MP940 Servo Control Function

The MP940 and SGD H SERVOPACK combine a servo and motion controller, connecting them through shared memory. Motion control is performed using direct commands to SGD H shared memory for all commands to the SERVOPACK, such as servo ON commands, control mode switching, speed commands, and torque control.

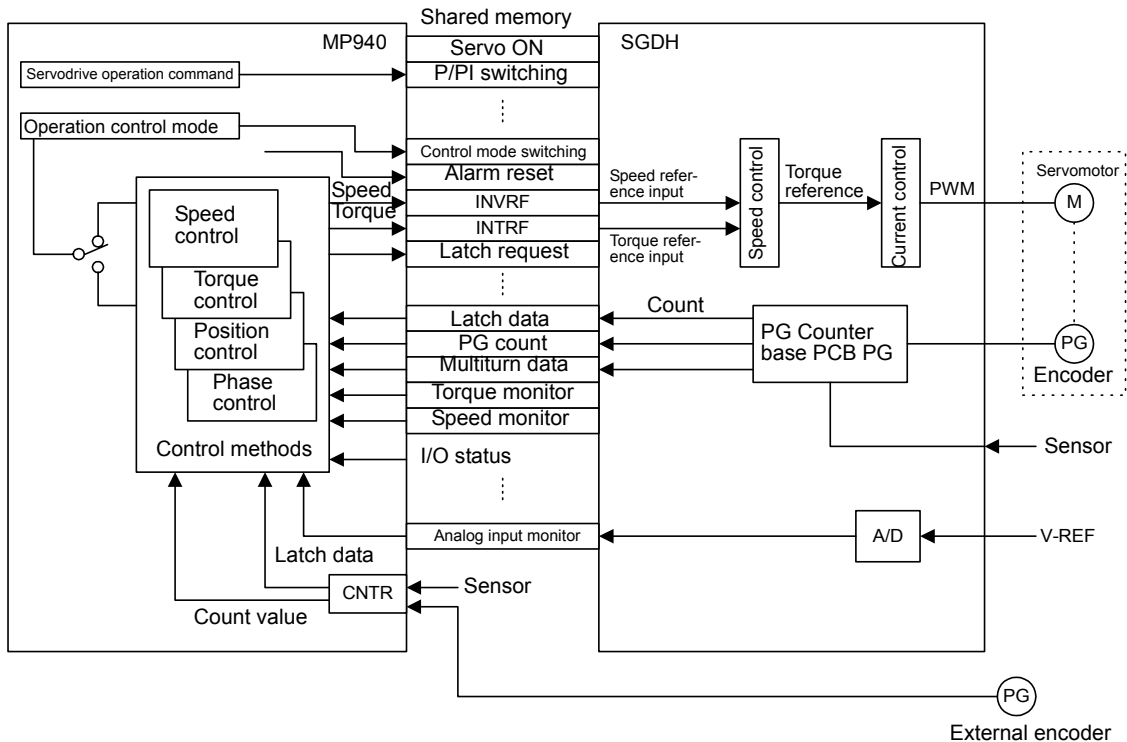

The MP940 servo control function has the following functions, which enable accurate, high-speed control.

■ Position, Speed, Torque, and Phase Control Switching during Operation

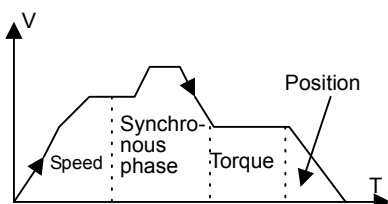

Operation mode switching is performed using the RUN Mode motion setting parameter (OWC000 bit 0 to bit 4).

■ SGDH SERVOPACK Speed Loop P/PI Switching during Operation

Application examples are given below.

- Suppressing overshoot during acceleration.
- Suppressing undershoot and reducing setting time.

Without Speed Loop P/PI Control Switching

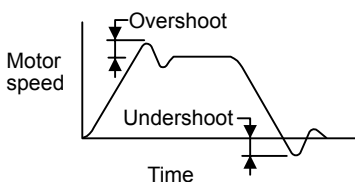

With Speed Loop P/PI Switching

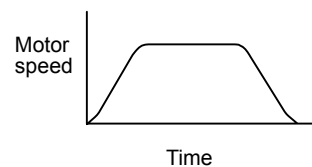

Speed loop P/PI switching is performed using the Operation Control motion setting parameter (OBC0011).

■ Changing Parameters during Operation

The following parameters can be changed immediately during operation using a ladder or motion program.

Parameter	Method of Change
Target position	Can be changed using the Position Reference Setting motion setting parameter (OLC012).
Speed	Can be changed using the Speed Control Setting motion setting parameter (OWC015) and the Fast Forward Speed Setting motion setting parameter (OLC022).
Acceleration and deceleration time constant	Can be changed using the Linear Acceleration Time Constant motion setting parameter (OWC00C) and the Linear Deceleration Time Constant motion setting parameter (OWC00D).
Position loop gain	Can be changed using the Position Loop Gain motion setting parameter (OWC010).

Parameter	Method of Change
Feed forward gain	Can be changed using the Feed Forward Gain motion setting parameter (OWC010).
Speed loop gain	1. Set the following parameters of the SGDH SERVOPACK beforehand. Pn100: Speed Loop Gain Pn101: Speed Loop Integral Time Constant
Speed loop integral time constant	Pn104: No. 2 Speed Loop Gain Pn105: No. 2 Speed Loop Integral Time Constant 2. Switch using the Gain Switch motion setting parameter (OBC0012) in the Run Commands (OWC001). Note: To change parameters of the SGDH SERVOPACK Pn100, Pn101, Pn104, and Pn105, use SGDH SERVOPACK command communications.
Position loop integral time constant	Can be changed using the Position Control Integral Time Constant motion setting parameter (OWC035).
Soft start acceleration time constant	Can be changed using the following SGDH SERVOPACK command communications: parameter of the SGDH SERVOPACK Pn305 “Soft Start Acceleration Time Constant” and parameter Pn306 “Soft Start Deceleration Time Constant”.
Soft start deceleration time constant	
Forward torque limit	There are two methods for switching the torque limit. 1. Control Using the Torque Limit Command from the MP940 Set the limit value using the Forward Torque Limit Setting motion setting parameter (OWC002). 2. Using Parameters of the SGDH SERVOPACK Change the parameters using SGDH SERVOPACK command communications. Pn402: Forward Torque Limit Pn403: External Input Forward Torque Limit Pn405: Reverse Torque Limit Pn406: External Input Reverse Torque Limit Switch between forward and reverse using the Forward External Torque Limit Input (OBC0013) and Reverse External Torque Limit Input (OBC0014) settings in the Servodriver Operation Commands motion setting parameter (OWC001).
Reverse torque limit	

■ Specifying Torque

During a speed reference, position control, or phase control, the torque limit can be controlled by setting a motion setting parameter.

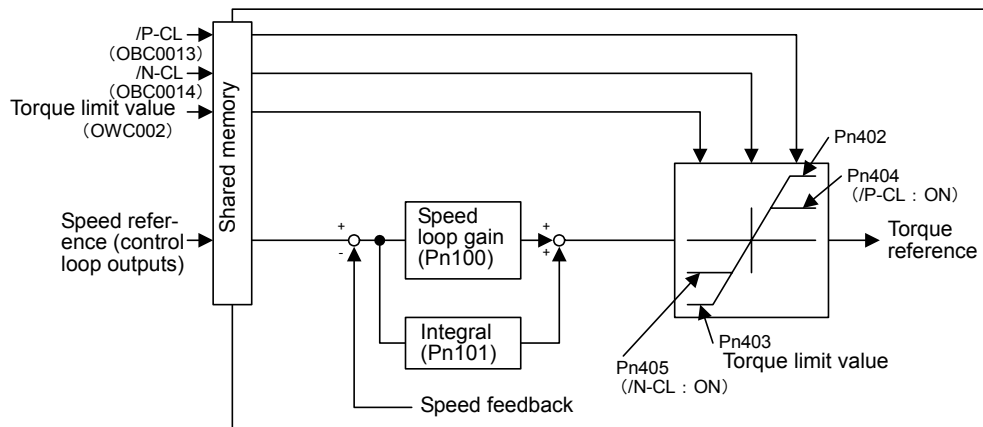

■ Referring to High-speed SGD H SERVOPACK Monitor Information

The following parameters can be referenced using the ladder or motion program while the servo is in operation.

Monitor Information	Referencing Method
Feedback position	Machine Coordinate Feedback Position motion monitor parameter (ILC008)
Position error	Position Error motion monitor parameter (ILC00A)
Reference position	Machine Coordinate Reference Position motion monitor parameter (ILC002)
Reference speed	Speed Reference Output Value motion monitor parameter (IWLC00C)
Motor speed	Speed Monitor motion monitor parameter (IWLC00D)
External encoder count	Hardware Counter Current Value Counter I/O Data Setting (IL0006) and Counter Current Value (IL000C)
SERVOPACK Status	The following signals can be referenced using the Servo Driver Status motion monitor parameter (IWC001). Bit 0: ALM: Servo Alarm Bit 1: WARM: Warning Bit 2: V-CMP: Speed Coincidence Bit 3: TGON: Motor Rotation Detected Bit 4: S-RDY: Servo Ready Bit 5: CLT: Torque Limit Detected Bit 6: VLT: Speed Limit Detected Bit 7: BK: Brake Interlock Bit 8: SVON: Servo ON Completed Bit 9: PON: Main Circuit Completed
SERVOPACK I/O status	The following signals can be referenced using the Servodriver I/O Status motion monitor parameter (IWC025). Bit 0: SIO: Standard Input Signal Bit 1: DEC: Deceleration LS Signal Bit 2: P-OT: Positive Overtravel Signal Bit 3: N-OT: Negative Overtravel Signal Bit 4: EXT1: External Input Signal 1 Bit 5: EXT1: External Input Signal 2 Bit 6: EXT1: External Input Signal 3

■ 1.5-axis Control Using an External Encoder Input

By using the MP940's Counter pulse input for an external encoder, you can perform conveyer tracking, array, labelling machine, or other external synchronous encoder control (1.5 axes).

Application Example

- Conveyer Tracking Processor

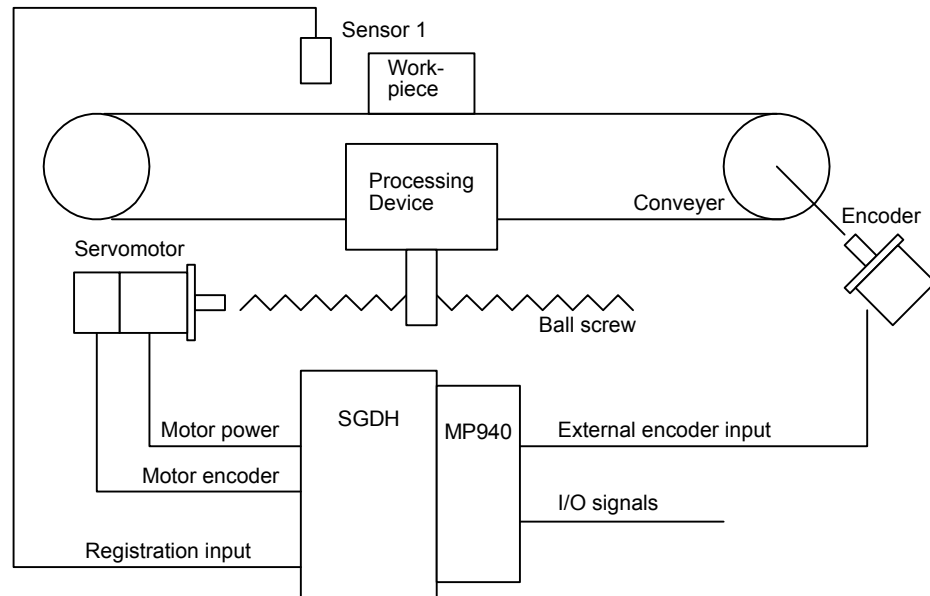

4.7.4 Setting Parameters of the SGDH SERVOPACK

If parameters of the SGDH SERVOPACK are used with an MP940 Module, they are used with the settings shown in the following table. Make the settings using the front operator, a Digital Operator, or the Default Setting (R) command on the Edit (E) Menu in the SERVOPACK Parameter Window before connecting the MP940 Module.

Parameter	Name	Setting	Contents	Remarks
Pn000.1	Control Method Selection	9	Torque control <= > Speed control	—
Pn002.0	Speed Control Option	1	Uses T-REF as an external torque limit input.	—
Pn002.1	Torque Control Option	1	Uses V-REF as an external speed limit input.	—
Pn003.0	Monitor 1	2	Torque reference	—
Pn003.1	Monitor 2	0	Motor speed	—
Pn005.0	Brake Control Function Selection	0	Controls the brake using the servos	—
Pn50A.0	Input Signal Allocation Mode	1	User signals can be allocated	—

Parameter	Name	Setting	Contents	Remarks
Pn50A.1	/S-ON Signal Mapping	8	Disabled	/S-ON uses signals in shared memory.
Pn50A.2	/P-CON Signal Mapping	8	Disabled	/P-CON uses signals in shared memory.
Pn50A.3	P-OT Signal Mapping	2	Allocated to SI2 (CN1-42)	Can be disabled.
Pn50B.0	N-OT Signal Mapping	3	Allocated to SI3 (CN1-43)	Can be disabled.
Pn50B.1	/ALM-RST Signal Mapping	8	Disabled	/ALM-RST uses signals in shared memory.
Pn50B.2	/P-CL Signal Mapping	8	Disabled	/P-CL uses signals in shared memory.
Pn50B.3	/N-CL Signal Mapping	8	Disabled	/N-CL uses signals in shared memory.
Pn50C.0	/SPD-D Signal Mapping	8	Disabled	–
Pn50C.1	/SPD-A Signal Mapping	8	Disabled	–
Pn50C.2	/SPD-B Signal Mapping	8	Disabled	–
Pn50C.3	/C-SEL Signal Mapping	8	Disabled	/C-SEL uses signals in shared memory.
Pn50D.0	/ZCLAMP Signal Mapping	8	Disabled	/Z-CLAMP uses signals in shared memory.
Pn50D.1	/INHIBIT Signal Mapping	8	Disabled	–
Pn50D.2	/G-SEL Signal Mapping	8	Disabled	/G-SEL uses signals in shared memory.
Pn511.0	/DEC signal mapping	1	Allocated to SI1 (CN1-41)	Enabled when signal is low.
Pn511.1	/EXT1 signal mapping	4	Allocated to SI4 (CN1-44)	Enabled when signal is low.
Pn511.2	/EXT2 signal mapping	5	Allocated to SI5 (CN1-45)	Enabled when signal is low.
Pn511.3	/EXT3 signal mapping	6	Allocated to SI6 (CN1-46)	Enabled when signal is low.

■ Pn000.1 and Pn002 Control Methods

The following table shows the details of the presumed conditions when using Pn000.1 and Pn002 in combination with an MP940.

Parameter	Setting	Details	Default Setting
Pn000.1 Control Method Selection	9	<p>Torque reference ↔ Speed reference (analog) Torque reference and speed reference can be switched.</p> <p style="text-align: center;">MP940 → SGDh SERVOPACK</p>	0
Pn002.1 Torque Control Option	1	<p>Torque Reference (when C-SEL = 0)</p> <ul style="list-style-type: none"> • Torque is controlled according to INTRF reference. • Speed can be controlled using INVRF. <p style="text-align: center;">MP940 → SGDh SERVOPACK</p>	0
Pn002.0 Speed Control Option	1	<p>Speed Reference (when C-SEL = 1)</p> <ul style="list-style-type: none"> • Speed is controlled according to INVRF reference. • Torque can be controlled using INTRF. <p style="text-align: center;">MP940 → SGDh SERVOPACK</p>	0

Note: The MP940 performs C-SEL switching automatically according the RUN Mode settings of the motion setting parameter (OWC000, Bit 0 to Bit 4).

■ Pn003.0: Analog Monitor 1 and Pn003.1: Analog Monitor 2

Parameter	Set Value	Details	Default Setting																																	
Pn003.0 (Analog Monitor 1)	2	Select the signal for analog monitoring. A maximum of 2 signals can be monitored.	2																																	
Pn003.1 (Analog Monitor 2)	0		0																																	
		<table border="1"> <thead> <tr> <th>Pn003.0/ Pn003.1 setting</th> <th colspan="2">Details</th> </tr> <tr> <th></th> <th>Monitor Signal</th> <th>Measurement Gain</th> </tr> </thead> <tbody> <tr> <td>0</td> <td>Motor speed</td> <td>1 V/1000 r/min</td> </tr> <tr> <td>1</td> <td>Speed reference</td> <td>1 V/1000 r/min</td> </tr> <tr> <td>2</td> <td>Torque reference</td> <td>1 V/100% rated torque</td> </tr> <tr> <td>3</td> <td>Position error</td> <td>0.05 V/1 reference unit</td> </tr> <tr> <td>4</td> <td>Position error</td> <td>0.05 V/100 reference units</td> </tr> <tr> <td>5</td> <td>Reference pulse frequency</td> <td>1 V/1000 r/min</td> </tr> <tr> <td>6</td> <td>Motor speed</td> <td>1 V/250 r/min</td> </tr> <tr> <td>7</td> <td>Motor speed</td> <td>1 V/125 r/min</td> </tr> <tr> <td>8 to E</td> <td>Reserved constant</td> <td>-</td> </tr> </tbody> </table>	Pn003.0/ Pn003.1 setting	Details			Monitor Signal	Measurement Gain	0	Motor speed	1 V/1000 r/min	1	Speed reference	1 V/1000 r/min	2	Torque reference	1 V/100% rated torque	3	Position error	0.05 V/1 reference unit	4	Position error	0.05 V/100 reference units	5	Reference pulse frequency	1 V/1000 r/min	6	Motor speed	1 V/250 r/min	7	Motor speed	1 V/125 r/min	8 to E	Reserved constant	-	
Pn003.0/ Pn003.1 setting	Details																																			
	Monitor Signal	Measurement Gain																																		
0	Motor speed	1 V/1000 r/min																																		
1	Speed reference	1 V/1000 r/min																																		
2	Torque reference	1 V/100% rated torque																																		
3	Position error	0.05 V/1 reference unit																																		
4	Position error	0.05 V/100 reference units																																		
5	Reference pulse frequency	1 V/1000 r/min																																		
6	Motor speed	1 V/250 r/min																																		
7	Motor speed	1 V/125 r/min																																		
8 to E	Reserved constant	-																																		
		<p>If using monitoring with the MP940, make the following settings.</p> <ul style="list-style-type: none"> • Pn003.0=2: Torque reference (1 V/100% rated torque) • Pn003.1=0: Motor rotation speed (1 V/1000 r/min.) <p>You can refer to the data from Analog Monitor 1 and Analog Monitor 2 using the MP940 monitor parameters.</p> <ul style="list-style-type: none"> • Torque reference=IWC00E • Motor rotation speed=IWC00D 																																		

■ Pn005.0: Brake Control

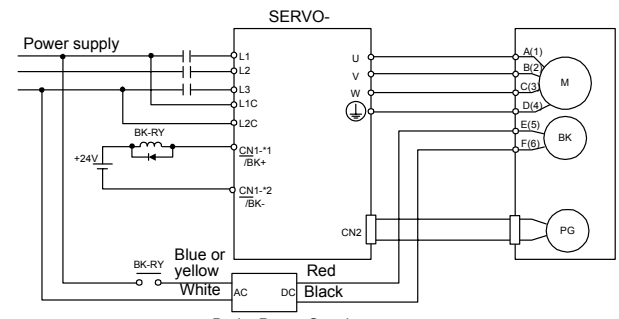
Parameter	Set Value	Details	Default Setting								
Pn005.0	0	<p>Brake Control Function Selection</p> <p>Use Pn005.0=0, SERVOPACK brake sequence.</p> <p>Use the SERVOPACK contact output signal /BK and the brake power supply to form a brake ON/OFF circuit. The following diagram shows a standard wiring example.</p>  <p>BK-RY: Brake control relay Brake power supplies are available for either 200 V or 100 V. *1 and *2 are the output terminals allocated with Pn50F.2.</p> <p>Related Parameters</p> <table border="1" data-bbox="606 978 1260 1191"> <tr> <td>Pn50F2</td> <td>Output Signal Selections 2</td> </tr> <tr> <td>Pn506</td> <td>Time Delay from Brake Reference until Servo OFF</td> </tr> <tr> <td>Pn507</td> <td>Speed Level for Brake Reference Output during Motor Operation</td> </tr> <tr> <td>Pn508</td> <td>Timing for Brake Reference Output during Motor Operation</td> </tr> </table> <p>Refer to <i>Chapter 6 Parameters</i> for details.</p>	Pn50F2	Output Signal Selections 2	Pn506	Time Delay from Brake Reference until Servo OFF	Pn507	Speed Level for Brake Reference Output during Motor Operation	Pn508	Timing for Brake Reference Output during Motor Operation	0
Pn50F2	Output Signal Selections 2										
Pn506	Time Delay from Brake Reference until Servo OFF										
Pn507	Speed Level for Brake Reference Output during Motor Operation										
Pn508	Timing for Brake Reference Output during Motor Operation										

■ Pn50A.0 to Pn50.B, Pn511

If using these parameters while connected to an MP940, set the allocation for the sequence input signal circuit as shown below.

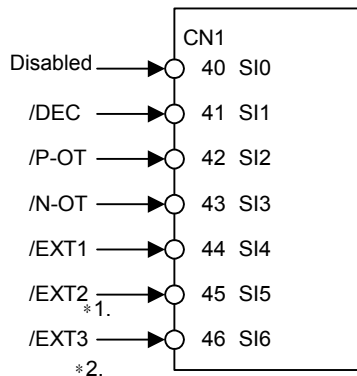

* 1. Use the /EXT2 signal as the ZERO signal.

* 2. Use the /EXT3 signal as the latch input signal.

Parameter	Name	Set Value	Details	Default Setting
Pn50A.0		1	Any sequence input signal can be set.	0
Pn50A.1	/S-ON Signal Mapping	8	Signal is always disabled. /S-ON uses a signal in shared memory.	0
Pn50A.2	/P-CON Signal Mapping	8	Signal is always disabled. /P-ON uses a signal in shared memory.	1
Pn50A.3	P-OT Signal Mapping	2	Input the P-OT signal on the SI2 input terminal (CN1-42). Can be disabled.	2
Pn50B.0	N-OT Signal Mapping	3	Input the N-OT signal on SI3 input terminal (CN1-43). Can be disabled.	3
Pn50B.1	/ALM-RST Signal Mapping	8	Signal is always disabled. /ALM-RST uses a signal in shared memory.	4
Pn50B.2	/P-CL Signal Mapping	8	Signal is always disabled. /P-CL uses a signal in shared memory.	5
Pn50B.3	/N-CL Signal Mapping	8	Signal is always disabled. /N-CL uses a signal in shared memory.	6
Pn511.0	/DEC Signal Mapping	1	Input /DEC signal on the SI1 input terminal (CN1-41).	8
Pn511.1	/EXT1 Signal Mapping	4	Input /EXT1 signal on the SI4 input terminal (CN1-44).	8
Pn511.2	/EXT2 Signal Mapping	5	Input /EXT2 signal on the SI5 input terminal (CN1-45).	8
Pn511.3	/EXT3 Signal Mapping	6	Input /EXT3 signal on the SI6 input terminal (CN1-46).	8

4.7.4 Setting Parameters of the SGDH SERVOPACK

When using parameters of the SGDH SERVOPACK with the MP940 Module, the I/O specifications will be as follows. For details of the SGDH SERVOPACK I/O signal, refer to 5.6 *SERVOPACK I/O Signals*.

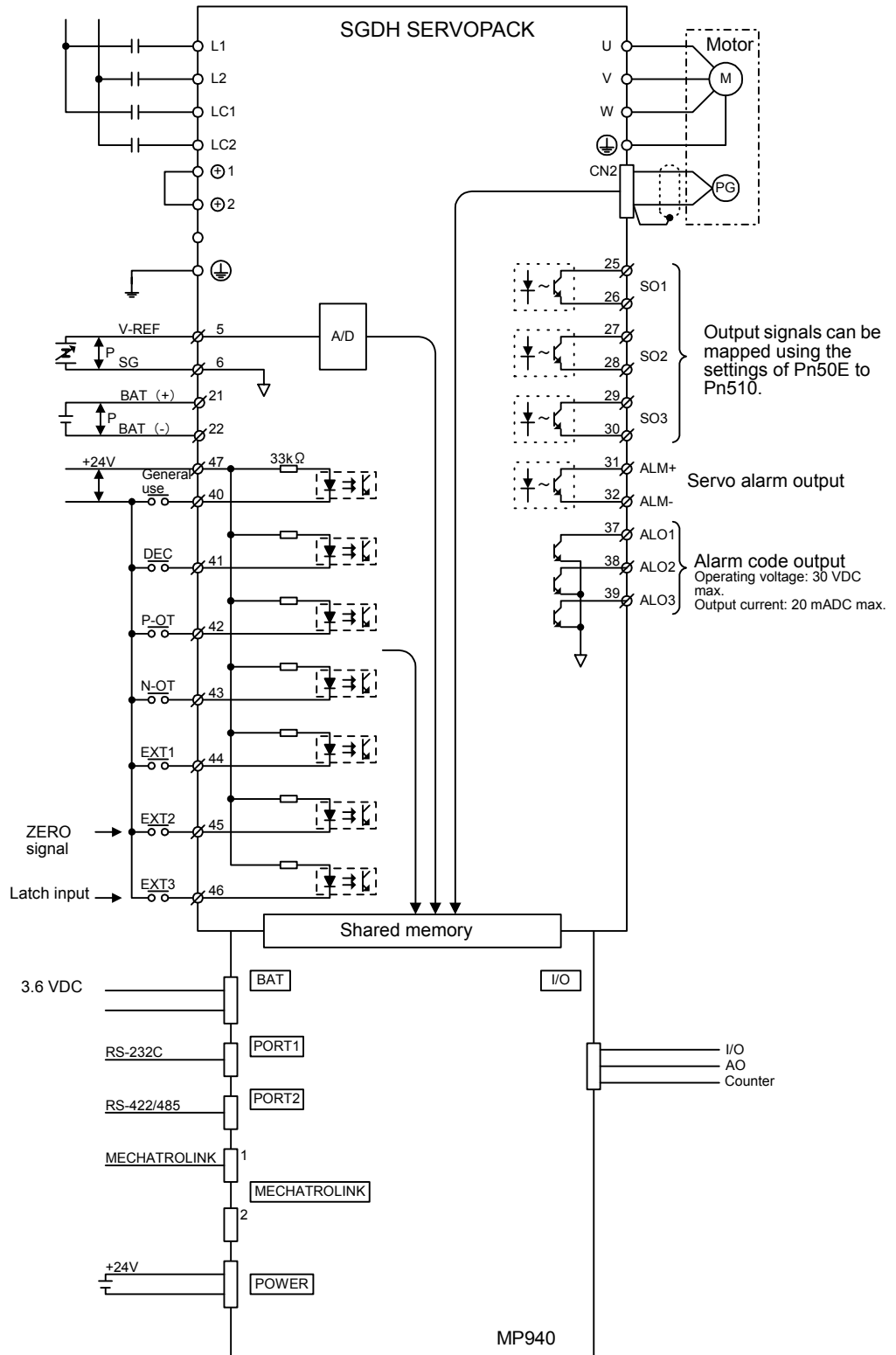

4.8 Flash Memory Operation

4.8.1 Overview

Normally, programs created by the user are stored in RAM. The CPU runs the programs stored in RAM with each scan. These programs can be saved to flash memory.

Loading programs from flash memory to RAM when the power supply is turned ON to use the programs stored in flash memory is called “FLASH operation.”

With flash memory, Programs can be saved even if there is no memory backup battery.

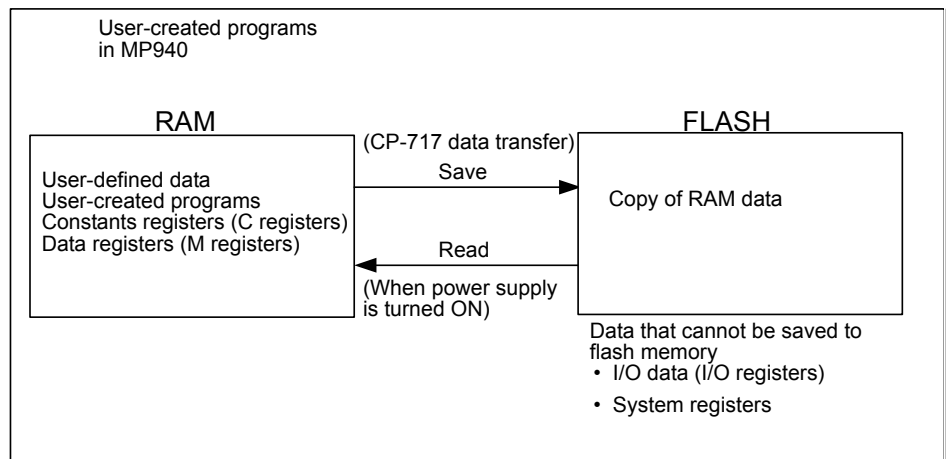

4

4.8.2 Saving to Flash

Use the CP-717 to save program data to flash memory. The procedure for transferring data is as follows:

1. Login online to the corresponding CPU



2. In File Manager, select **File Transfer (T)**, **Other (O)**, and then **Flash Save (S)** on the menu.

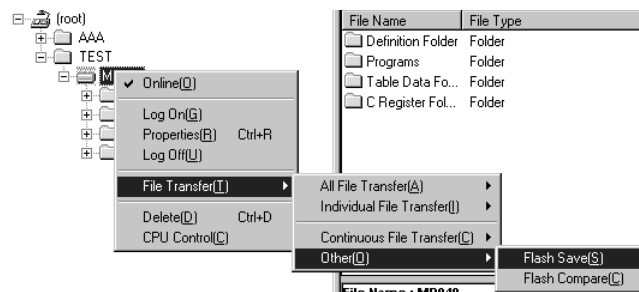

3. The Save Flash Memory Content Window will be displayed.

Select *Save/Compare Execute (S)* and then *Execute (S)* from the *File (F)* Menu.

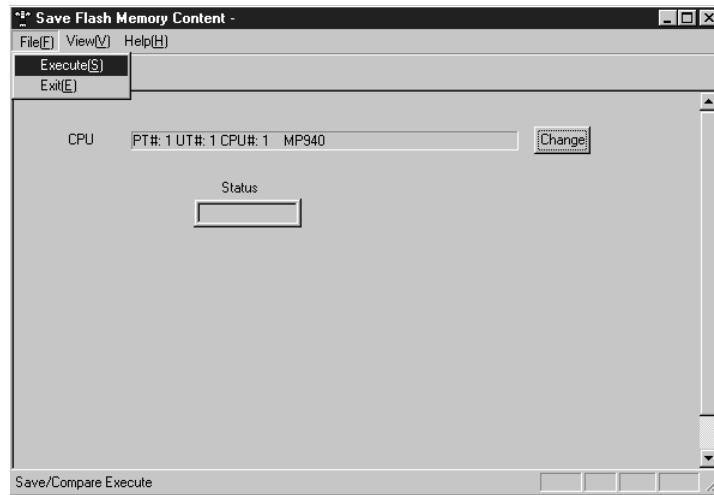

4. The Start Saving in Flash Memory Message Box will be displayed.

Click the **Yes (Y)** Button.

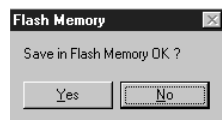

5. Data transfer has been completed when the displayed message box changes from “Running” to “Completed Normally”.

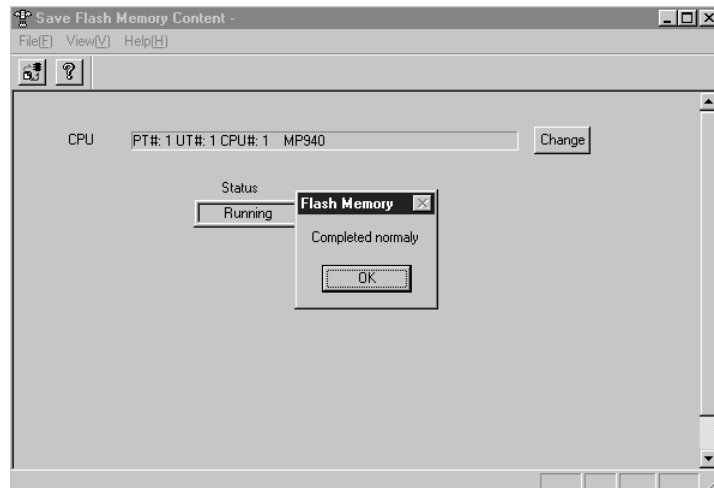

4.8.3 Starting Flash Memory

To transfer the programs stored in flash memory to the CPU before starting operation, set the DIP switch on the MP940 Module, turn OFF the power supply to the Module, then turn it ON again.

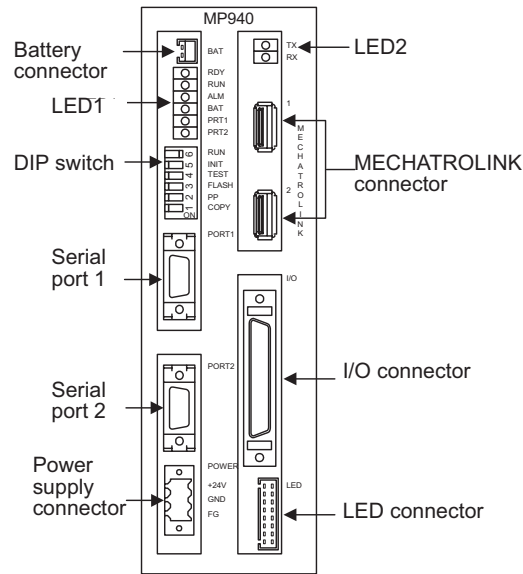

Turn ON pin 3 on the DIP switch (by moving it to the right) and then turn ON the power supply. Data will be transferred from flash memory to RAM.

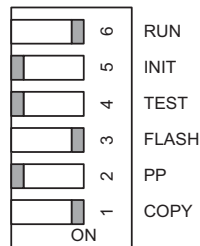

To also transfer the contents of M registers when transferring data from flash memory to RAM, turn ON pins 1 and 3 on the DIP switch, and then turn ON the power supply.

5 System Startup

This chapter explains the method of connecting the system and the startup procedure.

5.1 Handling the SERVOPACK	5-3
5.2 Part Names	5-4
5.2.1 MP940 Module	5-4
5.2.2 Accessories and Options	5-15
5.3 Connection Methods	5-16
5.3.1 Connectors	5-16
5.3.2 Connector Specifications	5-17
5.3.3 Serial Port Connector Pin Arrangements and I/O Circuits	5-18
5.3.4 I/O Connector Pin Arrangement and I/O Circuits	5-23
5.3.5 Power Supply Connector Cable	5-25
5.3.6 MECHATROLINK Cable	5-26
5.4 Connecting Peripheral Devices	5-28
5.4.1 Single Phase Power Supply Specifications	5-28
5.4.2 Three-phase Power Supply Specifications	5-29
5.4.3 Standard Cable Table	5-30
5.5 SERVOPACK Main Circuit Connection	5-33
5.5.1 Names and Descriptions of Main Circuit Terminals	5-33
5.5.2 Typical Main Circuit Wiring	5-34
5.5.3 Wiring Main Circuit Terminal Blocks	5-35
5.6 SERVOPACK I/O Signals	5-37
5.6.1 Examples of I/O Signal Connections	5-37
5.6.2 List of CN1 Terminals	5-38
5.6.3 I/O Signal Names and Functions	5-39
5.6.4 Interface Circuits	5-41

5.7 Wiring Encoders	5-43
5.7.1 Connecting an Encoder (CN2) and Output Signals from the SERVOPACK (CN1)	5-43
5.7.2 CN2 Encoder Connector Terminal Layout and Types	5-44
5.8 System Startup	5-46
5.8.1 Overview of the Startup Procedure	5-46
5.8.2 Test System Configuration	5-47
5.8.3 Test System Outline	5-48
5.8.4 Equipment Preparations	5-49
5.8.5 Mounting the MP940 Module	5-50
5.8.6 Mounting the Battery Holder	5-52
5.8.7 Connections and Wiring	5-54
5.8.8 MP940 Initialization	5-55
5.8.9 Starting the CP-717	5-57

5.1 Handling the SERVOPACK

This section provides the names of the parts of the SERVOPACK and a general explanation of each part.

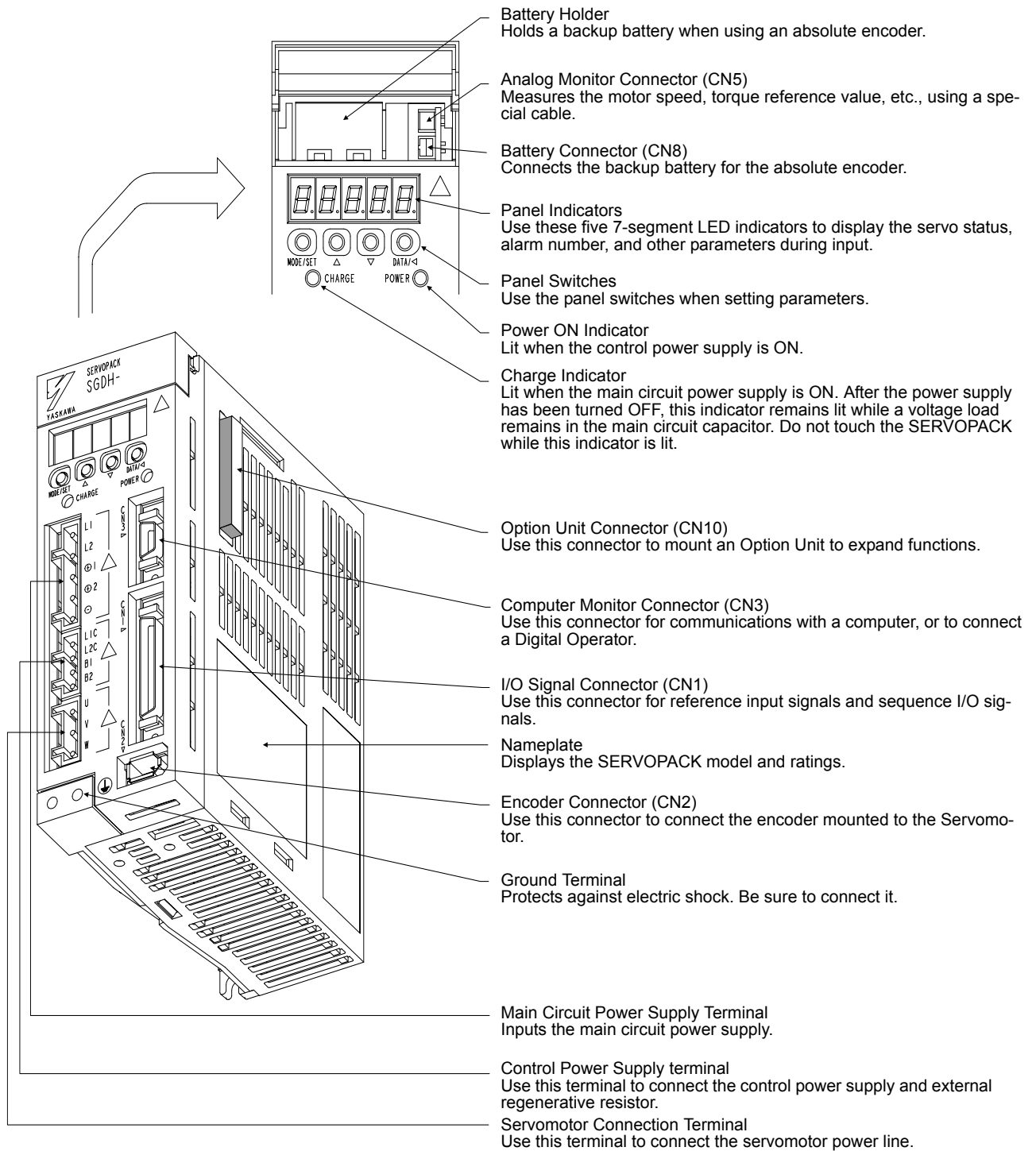

5.2 Part Names

This section provides the names of the parts of the MP920 and a general explanation of each part.

5.2.1 MP940 Module

The following illustration shows the appearance of the MC400 MP940 Module.

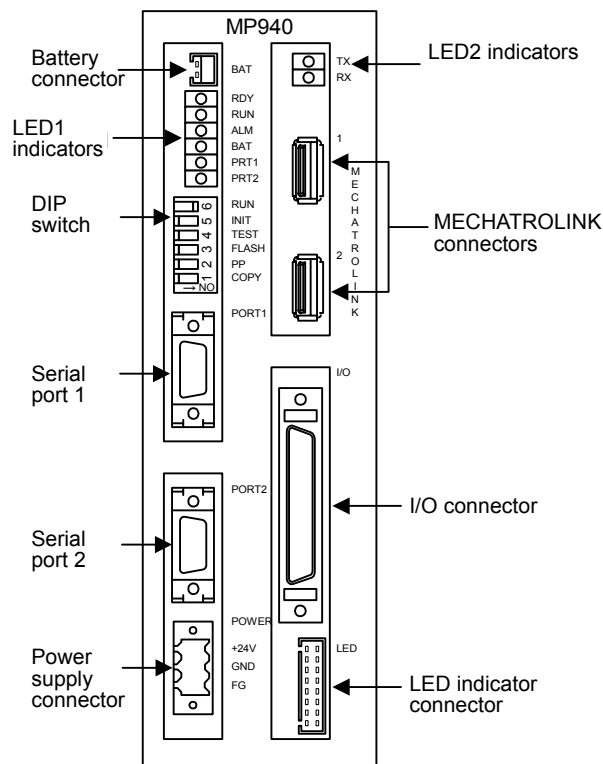

■ LED 1 Indicators

LED1 indicators show the Module's status.

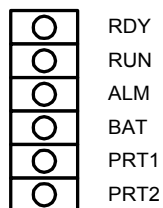

Name	Indicator Color	Meaning when Lit or Flashing
RDY	Green	System operating normally.
RUN	Green	Program running.
ALM	Red	Lit: Minor system failure occurred. Flashing: System fault or failure occurred.
BAT	Red	Battery needs replacing.
PRT1	Green	Serial port 1 sending data.
PRT2	Green	Serial port 2 sending data.

■ LED 2 Indicators

LED2 indicators show the MECHATROLINK's status.



TX
RX

Name	Indicator Color	Meaning when Lit
TX	Green	Sending data.
RX	Green	Receiving data.

■ Battery Connector

Connects a battery to back up the contents of program memory.

- Connector model: DF3-2P-2DS (HIROSE)
- Battery: ER6VLY+DF3.CONNECTOR



BAT

Terminal Name	Function
BAT IN	Battery input
GND	Terminal ground

■ DIP Switch

The DIP switch consists of six pins. The pins are numbered from 1 to 6, as shown in the diagram with the following table.

Each pin turns ON when it is moved to the right.

Pin settings are enabled the next time the power supply is turned ON.

The function of each pin is given in the following table.

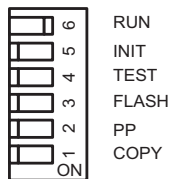

6 RUN
5 INIT
4 TEST
3 FLASH
2 PP
1 COPY
ON

Pin	Name	Setting	Function	Default
6	RUN	ON	Program executed.	ON
		OFF	Program stopped.	
5	INIT	ON	Pin 4 OFF: ON: Memory cleared.	OFF
		OFF	Pin 4 OFF: Normal ON: Setting prohibited	
4	TEST	ON	Terminal mode/initialization mode	OFF
		OFF	Online	
3	FLASH	ON	Program copied from flash memory to RAM.	OFF
		OFF	Program not copied from flash memory to RAM.	
2	PP	ON	Use defaults for serial port 1.	OFF
		OFF	Use memory settings.	
1	COPY (Valid when pin 3 is ON)	ON	Copying M-register from flash memory enabled.	OFF
		OFF	Copying M-register from flash memory disabled.	

Serial Port 1

The MP940 Module can perform communications using RS-232C with communications devices on a MEMOBUS network via serial port 1.

Connect a Programming Device (a personal computer equipped with a RS-232C interface) to serial port 1.

Connecting a Programming Device

The following diagram shows an example of a Programming Device connected to serial port 1.

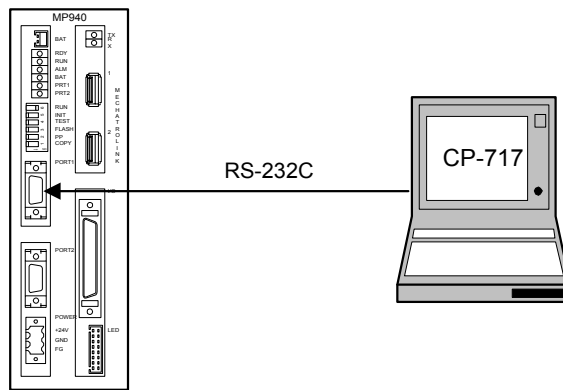

Connector Pin Arrangement and Signal Names

The following table lists the serial port 1 connector pin arrangement and signal names.

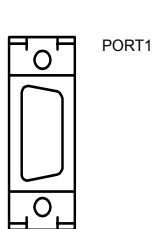

No.	Signal Name	Remarks	No.	Signal Name	Remarks
1	TXD	Transmit data	8		
2			9		
3	RXD	Receive data	10		
4			11		
5			12	RTS	Request to send
6	CTS	Clear to send	13	-	
7			14	GND	Signal ground

■ Serial Port 2

Use this port to connect RS-422/485.

Multiport Connections to External Devices

The following example shows the multiport connection of external devices to serial port 2.

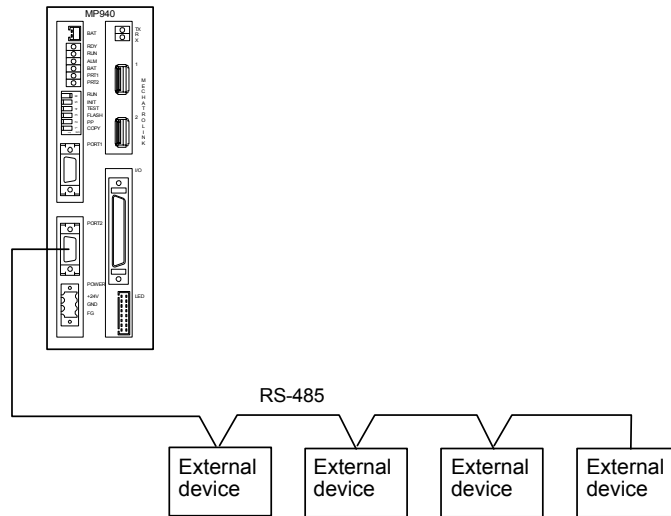

Connector Pin Arrangement and Signal Names

The following table lists the serial port 2 connector pin arrangement and signal names.

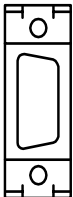

No.	Signal Name	Remarks	No.	Signal Name	Remarks
1	TX +	Transmit data positive side	8	TX +	Transmit data positive side
2	TX -	Transmit data negative side	9	TX -	Transmit data negative side
3	RX +	Receive data positive side	10	RX +	Receive data positive side
4	RX -	Receive data negative side	11	TXR	Transmit data terminating resistance
5			12		
6	RX -	Receive data negative side	13	VCC	Power supply (+5 V)
7	RXR	Receive data terminating resistance	14	GND	Signal ground

■ Power Supply Connector

A 24-VDC power supply is supplied to the MP940 Module.

The connector is a screw-locked terminal block connector (BL3.5/3F-AU, manufactured by Weidmüller).

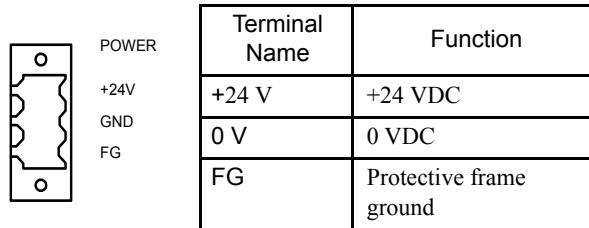

■ MECHATROLINK Connector for JEPMC-MC400

Connect distributed I/O and other devices via MECHATROLINK.

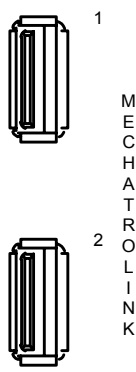
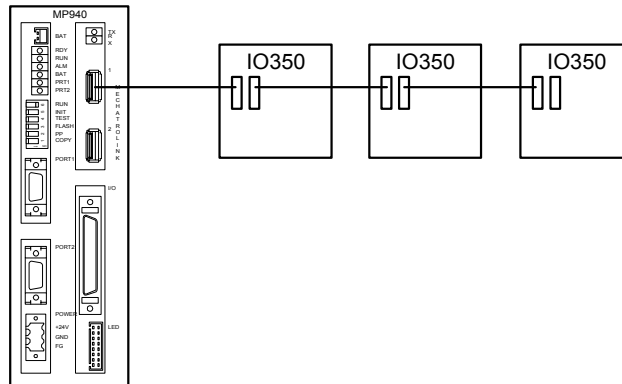

No.	Function
1	N.C
2	SRD-
3	SRD+
4	Shield

■ I/O Connector

Use the I/O connector to connect the MP940 Module to external input signals, analog outputs, and pulse inputs.

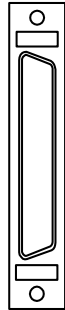

I/O

- External input: 8 points
- External output: 8 points
- Analog output: 0 to ±10 V
- Pulse input: 5 V differential pulse, A/B signals, counter latch input

■ LED Indicator Connector

By connecting the LED block shown below, the status of DI/DO connected to the I/O connector can be displayed.

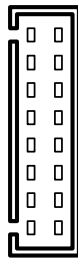

LED

No.	Signal Name	Remarks	No.	Signal Name	Remarks
1	VCC	Power supply (+5 V)	2	-	
3	-		4	LED0*	
5	LED1*		6	-	
7	LED2*		8	LEDPW0	
9	LEDPW3		10	LEDPW2	
11	LED3*		12	LED4*	
13	LED5*		14	LEDPW1	
15	LED7*		16	LED6*	

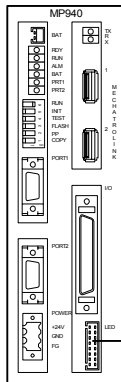

LED indicator block

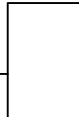

MP940 LED Indicator Block

R	ACTIVE	F		
1	9	17	25	
2	10	18	26	
3	11	19	27	
4	12	20	28	
5	13	21	29	
6	14	22	30	
7	15	23	31	
8	16	24	32	

Fig 5.1 Appearance of LED Indicator Block

No.	Signal Name	Meaning when Lit	No.	Signal Name	Meaning when Lit
1	DI0	DI0 inputting	9	DO0	DO0 outputting
2	DI1	DI1 inputting	10	DO1	DO1 outputting
3	DI2	DI2 inputting	11	DO2	DO2 outputting
4	DI3	DI3 inputting	12	DO3	DO3 outputting
5	DI4	DI4 inputting	13	DO4	DO4 outputting
6	DI5	DI5 inputting	14	DO5	DO5 outputting
7	DI6	DI6 inputting	15	DO6	DO6 outputting
8	DI7	DI7 inputting	16	DO7	DO7 outputting

Note: Other numbers and signals are not used.

LED Indicator Specifications

The following table shows the 260IF LED indicator specifications.

Table 5.1 LED Indicator Specifications

Name	Indicator Color	Status	Meaning
MS	Red/Green	Unlit	Power not supplied to the Module
		Lit green	Operating normally.
		Lit red	Self-diagnosis error/WDT error
NS	Red/Green	Unlit	Power not supplied/Module is offline ^{*1}
		Flashing green	Module is online, but connection cannot be confirmed.
		Lit green	Module is online and connection is confirmed.
		Flashing red	DeviceNet not communicating
		Lit red	Communications not possible (MAC ID overlapped)/Bus OFF error WDT error ^{*2}

- * 1. The offline status indicates the status during the time from when the LED indicator test has been completed immediately after startup, until the MAC ID overlapping check has been completed (approx. 2 s). The online status indicates the status after the MAC ID overlapping check.
- * 2. If the error is caused by a disconnected network power supply, Automatic Reset is activated even when a DeviceNet bus off error occurs. NS lights red momentarily, and then turns OFF immediately. After the power supply of the network has been recovered, NS flashes green.

Immediately after the power supply has been turned ON, the MS and NS LED indicators will be tested for 1 second according to DeviceNet specifications. The status displayed by this operation is shown in the following flowchart.

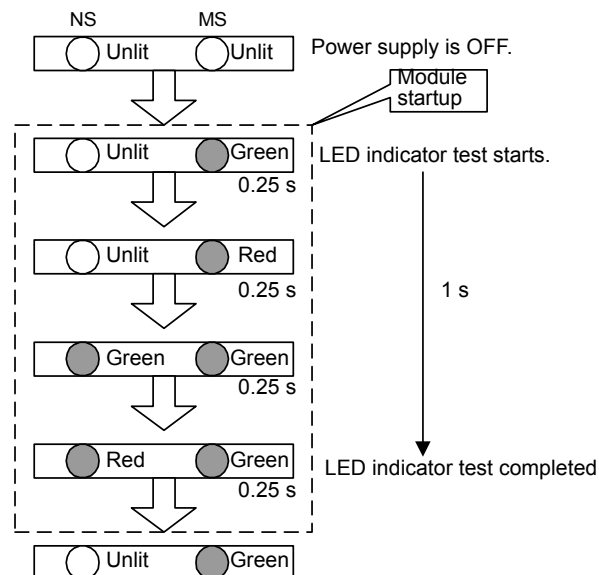
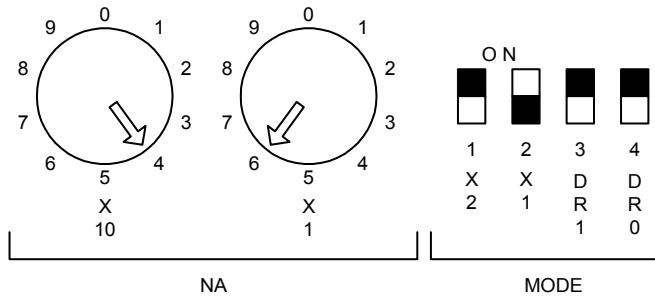

Fig 5.2 Display during LED Indicator Test

Switch Specifications

This section explains the switches on the MP940D for setting the DeviceNet baud rate and MAC ID settings.



MODE Switch

Use this DIP switch to set the DeviceNet baud rate and select whether the Module is a master or slave. The MP940, however, cannot be used as a master.

Table 5.2 SW1 specifications

Name	Meaning	Setting															
DR0	DeviceNet baud rate	<table border="1"> <thead> <tr> <th>DR1</th> <th>DR0</th> <th></th> </tr> </thead> <tbody> <tr> <td>OFF</td> <td>OFF</td> <td>125 Kbps (factory setting)</td> </tr> <tr> <td>OFF</td> <td>ON</td> <td>250 Kbps</td> </tr> <tr> <td>ON</td> <td>OFF</td> <td>500 Kbps</td> </tr> <tr> <td>ON</td> <td>ON</td> <td>Setting prohibited</td> </tr> </tbody> </table>	DR1	DR0		OFF	OFF	125 Kbps (factory setting)	OFF	ON	250 Kbps	ON	OFF	500 Kbps	ON	ON	Setting prohibited
DR1		DR0															
OFF		OFF	125 Kbps (factory setting)														
OFF		ON	250 Kbps														
ON		OFF	500 Kbps														
ON	ON	Setting prohibited															
DR1																	
X1	DeviceNet mode setting	OFF: DeviceNet Slave mode (factory setting) ON: DeviceNet Master mode (Cannot be set.)															
X2	Not used.	Always OFF.															

NA Switch

Use these rotary switches to set the MAC ID for DeviceNet.

Table 5.3 SW2 and SW3 Specifications

Name	Meaning	Meaning
X10 (SW2)	MAC ID 10s digit switch	Set the 2-digit local node MAC ID (0 to 63) in decimal using the two rotary switches. (factory setting: 00)
X1 (SW3)	MAC ID 1s digit switch	

IMPORTANT

- Mount the MP940 on the side of the SGD H SERVOPACK for use. Be sure to mount the MP940 on the SGD H SERVOPACK in the correct direction.

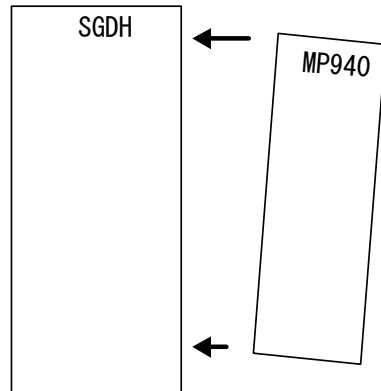

- Turn ON the power supply to the SGD H SERVOPACK within 10 seconds after turning ON the power supply to the MP940. Failure to do so may result in the MP940 not being synchronized with the SGD H SERVOPACK, and it will start to operate independently.
- If not using a cooling fan or similar device, mount the SGD H SERVOPACK and MP940 facing the correct orientation.

Correct

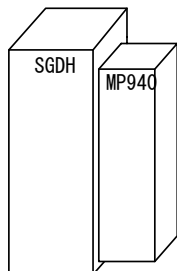

Wrong

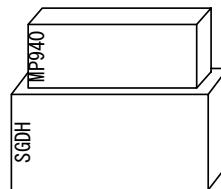

- Always ground the FG to 100 Ω max.

5.2.2 Accessories and Options

■ MP940 Accessories Table

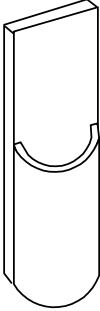
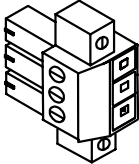
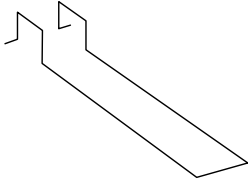
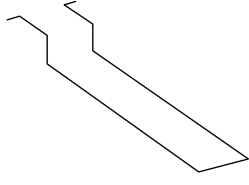
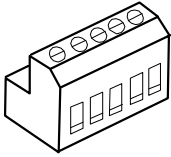
Model Number	Name	Appearance
-	Battery holder	
BL3.5/3F-AU	Power supply connector Connects to the POWER connector.	
Spring A Spring B	Mounting springs, 2 types Spring A × 2 Spring B × 2	<div style="display: flex; justify-content: space-around;"> <div style="text-align: center;">  <p>A</p> </div> <div style="text-align: center;">  <p>B</p> </div> </div>
	DeviceNet connector	

5

■ Options

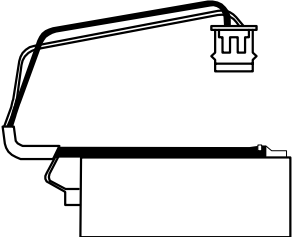
Model Number	Name	Appearance
BA000518	MP940 Module memory backup battery	

5.3 Connection Methods

This section describes connection details for each Module.

5.3.1 Connectors

The following illustration shows the names and locations of the connectors mounted on the front panel of the MP940 Module.

■ JEPMC-MC400

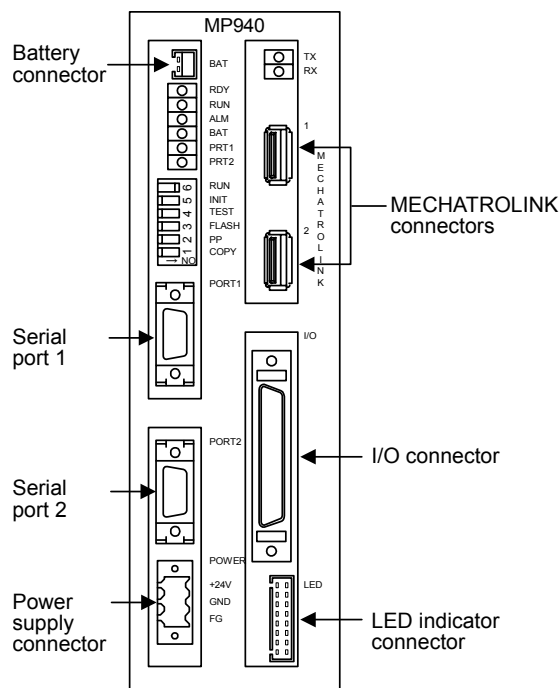

■ JEPMC-MC410

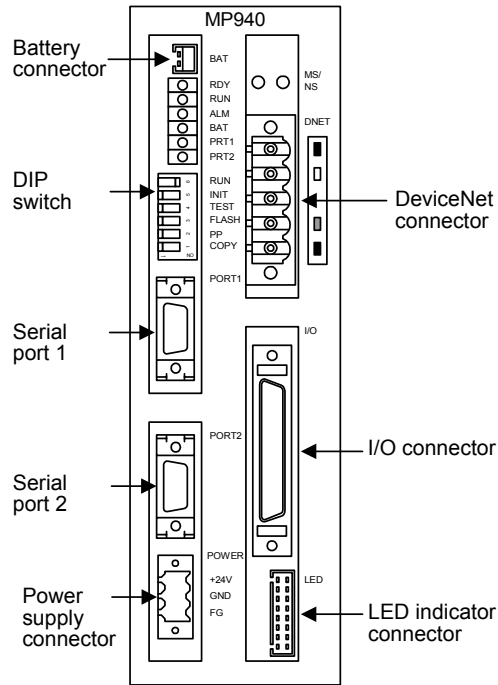

5.3.2 Connector Specifications

The following table shows the specifications of the connectors shown in *5.3.1 Connectors*.

Name	Connector Name	Number of Pins	Connector			Cable
			On Module	On Cable	Manufacturer	
Battery connector	BAT	2	DF3-2P-2DS	Battery ER6VLY+DF3, CONNECTOR	HIROSE	BA000518
RS-232C serial port	PORT1	14	10214-52A2JL	<ul style="list-style-type: none"> Connector 10114-3000VE Shell 10314-52A0-008 	3M	JEPMC-W5314-03 JEPMC-W5314-15
RS-422/485 serial port	PORT2	14	10214-52A2JL	<ul style="list-style-type: none"> Connector 10114-3000VE Shell 10314-52A0-008 	3M	-
Power supply connector	POWER	3	3L3.5/3/90F	BL3.5/3F-AU	Weidmüller	-

Name	Connector Name	Number of Pins	Connector			Cable
			On Module	On Cable	Manufacturer	
MECHATRO-LINK connector	MECHATRO-LINK	4	DUSB-ARA41-T11	• Connector DUSB-APA41-B1-C50 • USB to USB type	DDK	JEPMC-W6000-A3
				• Connector DUSB-APA41-B1-C50 • USB to loose wire type	DDK	JEPMC-W6010-01 JEPMC-W6010-03 JEPMC-W6010-05
				• Connector DUSB-APA41-B1-C50 • USB terminator	DDK	JEPMC-W6020
I/O connector	I/O	50	10250-52A2JL	• Connector 10150-3000VE • Shell 10350-52A0-008	3M	JZMSZ-120W0402-01 JZMSZ-120W0402-03 JZMSZ-120W0402-05
LED indicator connector	LED	16	IMSA-9220B-16A	–	–	–

5.3.3 Serial Port Connector Pin Arrangements and I/O Circuits

■ Serial Port 1

Connector Pin Arrangement and Signal Names

The following table describes the serial port 1 connector pin arrangement and signal names.

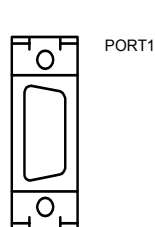

No.	Signal Name	Remarks	No.	Signal Name	Remarks
1	TXD	Transmit data	8		
2			9		
3	RXD	Receive data	10		
4			11		
5			12	RTS	Request to send
6	CTS	Clear to send	13	-	
7			14	GND	Signal ground

- Module connector: 10214-52A2JL (3M)
- Cable connector: 10114-3000VE (3M)
- Shell: 10314-52A0-008 (3M)

Serial Port 1 (RS-232C) Connection

The serial port 1 (RS-232C) connection is shown below.

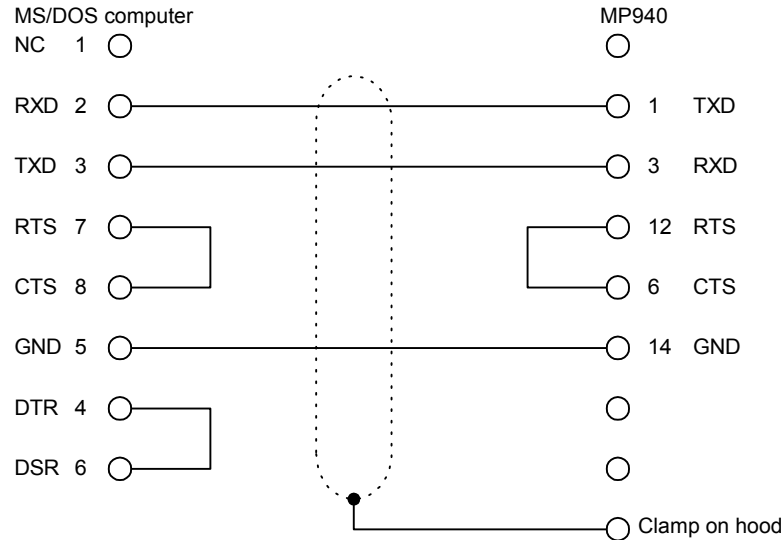

Serial Port 2

Connector Pin Arrangement and Signal Names

The following table describes the serial port 2 connector pin arrangement and signal names.

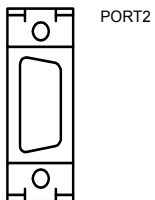

No.	Signal Name	Remarks	No.	Signal Name	Remarks
1	TX +	Transmit data positive side	8	TX +	Transmit data positive side
2	TX -	Transmit data negative side	9	TX -	Transmit data negative side
3	RX +	Receive data positive side	10	RX +	Receive data positive side
4	RX -	Receive data negative side	11	TXR	Transmit data terminating resistance ^{*2}
5			12		
6	RX -	Receive data negative side	13	VCC	Power supply (+5 V)
7	RXR	Receive data terminating resistance ^{*1}	14	GND	Signal ground

* 1. The terminating resistance (100 Ω) is connected by connecting to RX(-).

* 2. The terminating resistance (100 Ω) is connected by connecting to TX(-).

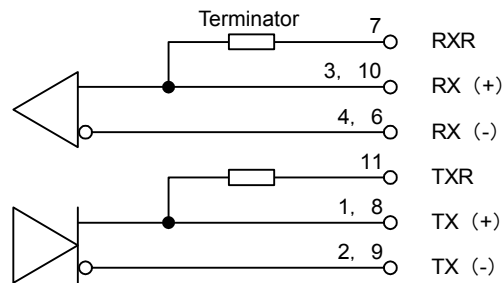

To connect terminating resistance, connect it to signals RXR and RX(-), and signals TXR and TX(-) as described in the diagram. If no connect resistance is terminating, open signals RXR and TXR.

- Module connector: 10214-52A2JL (3M)
- Cable connector: 10114-3000VE (3M)
- Shell: 10314-52A0-008 (3M)

■ RS-422/485 Interface Cable

IMPORTANT

- Be sure to separate the interface cable from the power system, control system, power supply system, and other transmission systems.
- The RS-422/485 interface of the MP940 Interface Module is MDR-14 pin (CN3).
- The maximum cable length of RS-422/485 is 300 m. Use a cable as short as possible.
- The RS-422/485 interface of the MP940 is not insulated. Noise from the terminal to be connected may cause a malfunction of the MP940. Use shielded cables or a modem to reduce the noise if necessary.
- When using RS-422, insert terminating resistance if necessary. Termination must be made at the receiving end.
- When using RS-485, add terminating resistance to both ends of the transmission line.

■ RS-422 Connection Example

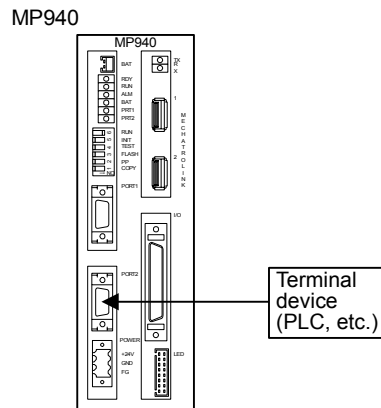

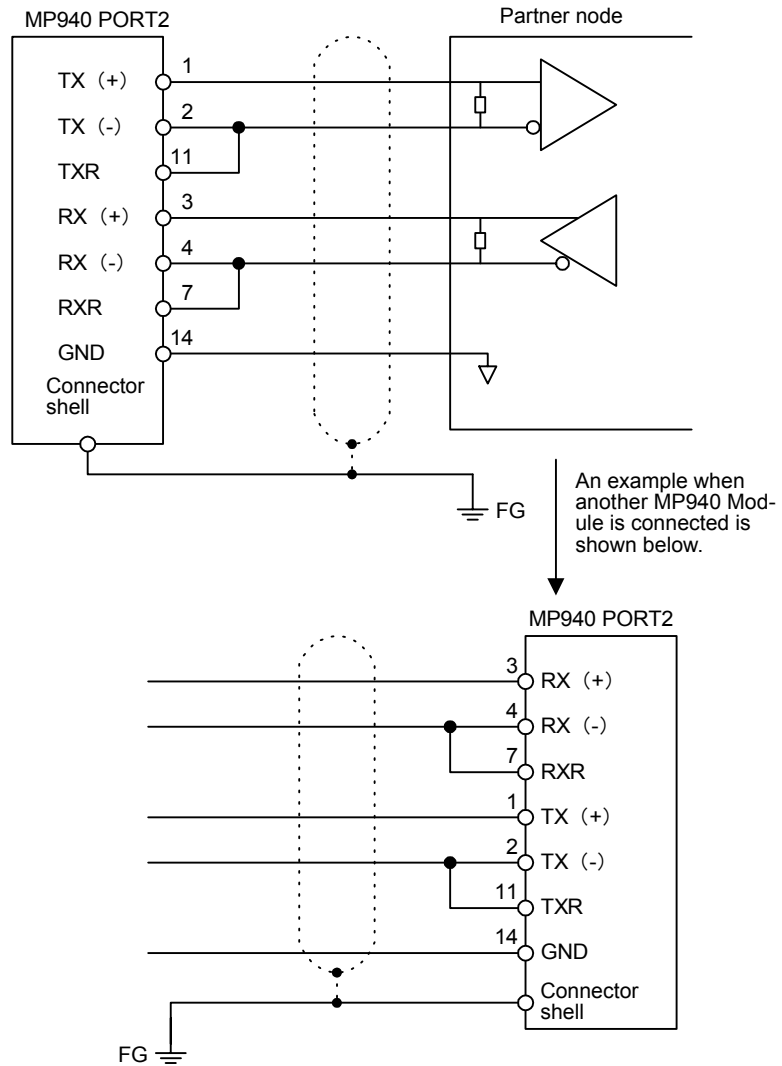

5

■ RS-485 Connection Example

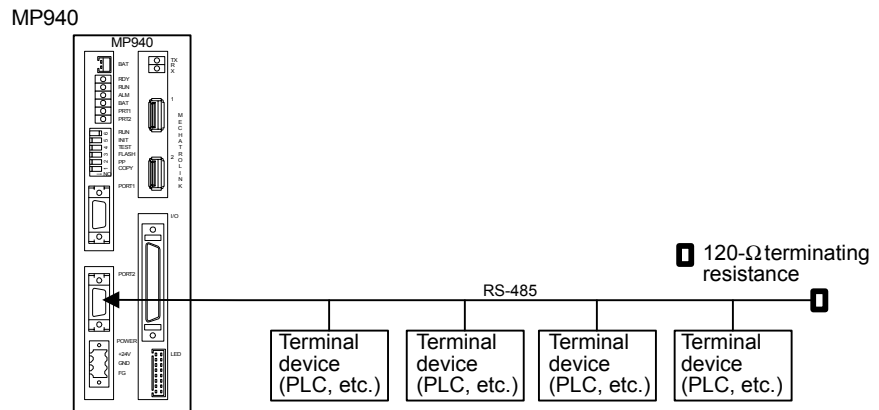

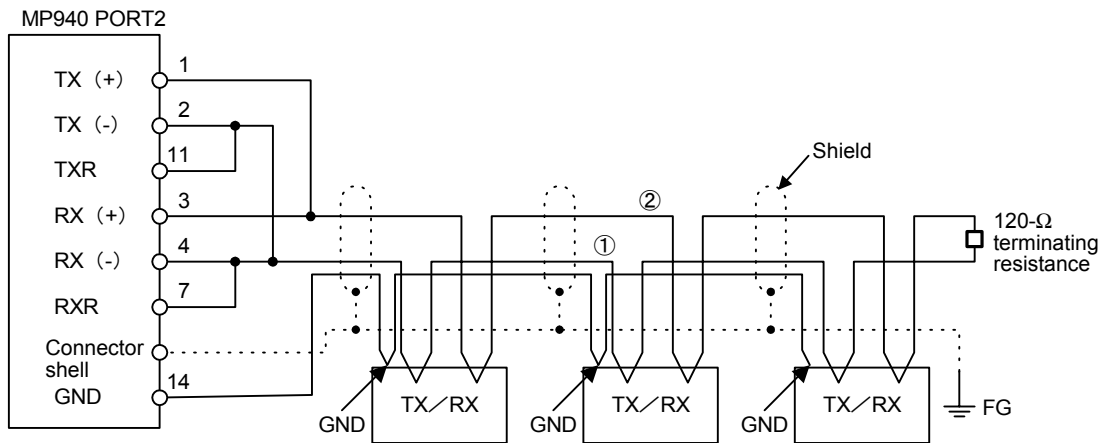

An example when the MP940 Module is connected in the middle of the connection is shown below.

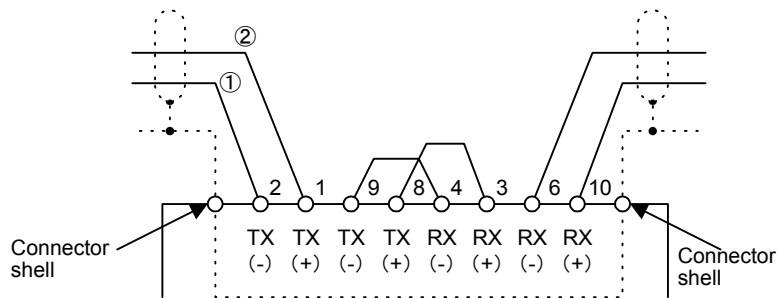

Note: For the port 2 interface, the terminating resistance activated by connecting 2 to 11 and 4 to 7.

5.3.4 I/O Connector Pin Arrangement and I/O Circuits

■ I/O Connector Pin Arrangement

The names of the I/O connector terminals and their functions are shown in the following table.

No.	Signal Name	Remarks	No.	Signal Name	Remarks
1	AO	Analog output	26	AO_GND	Analog output ground
2			27		
3			28		
4	PA+	A pulse positive	29	PB+	B pulse positive
5	PA-	A pulse negative	30	PB-	B pulse negative
6	GND	Pulse input ground	31	GND	Pulse input ground
7			32		
8			33		
9	PILC 5 V	PI latch input common (5 V)	34	PILC 12 V	PI latch input common (12 V)
10	PILC 24V	PI latch input common (24 V)	35	PIL	PI latch input common
11			36		
12			37		
13	24 VDC	DI power supply	38	24 VDC	DI power supply
14	DI_00	DI_00 input (DI interrupt)	39	DI_01	DI_01 input
15	DI_02	DI_02 input	40	DI_03	DI_03 input
16	DI_04	DI_04 input	41	DI_05	DI_05 input
17	DI_06	DI_06 input	42	DI_07	DI_07 input
18			43		
19			44		
20	24 VDC	DO power supply	45	24 VDC	DO power supply
21	DO_00	DO_00 output	46	DO_01	DO_01 output
22	DO_02	DO_02 output	47	DO_03	DO_03 output
23	DO_04	DO_04 output	48	DO_05	DO_05 output
24	DO_06	DO_06 output	49	DO_07	DO_07 output (counter coincidence output)
25	DO_GND	DO ground (0 V)	50	DO_GND	DO ground (0 V)

■ I/O Connector I/O Circuits

The I/O connector connections and I/O circuits are shown below.

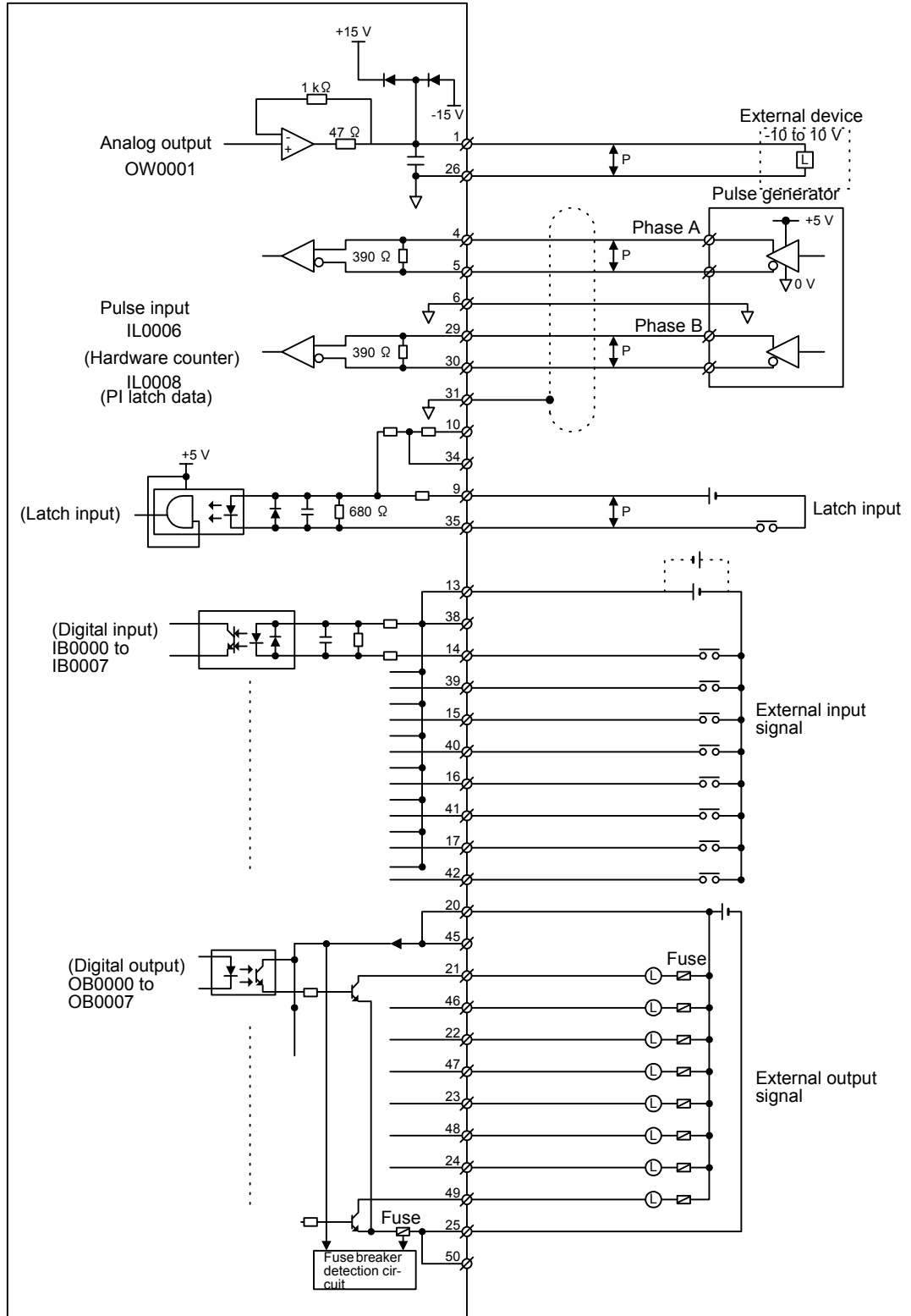

Note: The I/O signal register numbers use the default addresses.

5.3.5 Power Supply Connector Cable

■ Power Supply Connector (POWER)

The MP940 Module must be supplied with a 24-VDC power supply.

The connector is a screw-locking terminal block connector (BL3.5/3F-AU, manufactured by Weidmüller).

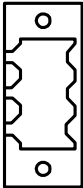
	POWER		
	+24V		
	GND		
	FG		
	Pin No.	Signal Name	Name
	3	+24 V	+24-VDC input
	2	GND	0 V
	1	FG	

■ 24-V Input Cable Preparing Procedure

Use a twisted-pair cable with a wire size of AWG #24 to AWG #20 (0.2 mm^2 to 0.51 mm^2) when connecting the 24-VDC power supply and MP940 Module power supply connector.

Prepare a cable using the following procedure.

1. Strip the wire of its covering.

Strip the wire of its covering for 6.5 mm from the head.

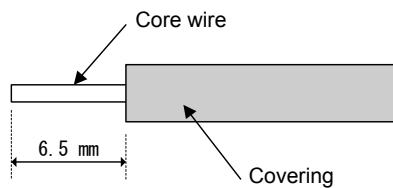

2. Insert the wire to a plug.

Insert the core wire deeply into the plug and tighten the screws with a 0.3 to 0.4 Nm fastening torque.

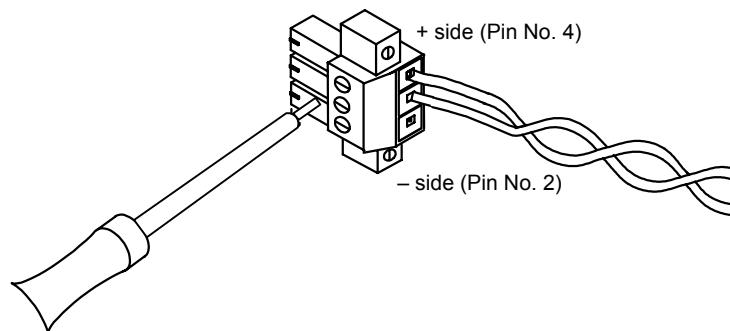

Pin No.	Signal Name	Name
3	+24 V	+24-VDC input
2	GND	GND
1	FG	FG

5.3.6 MECHATROLINK Cable

The internal cable connection between the MP940 Module I/O Units (e.g., IO350) is shown below.

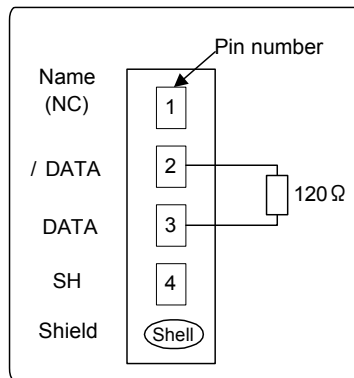
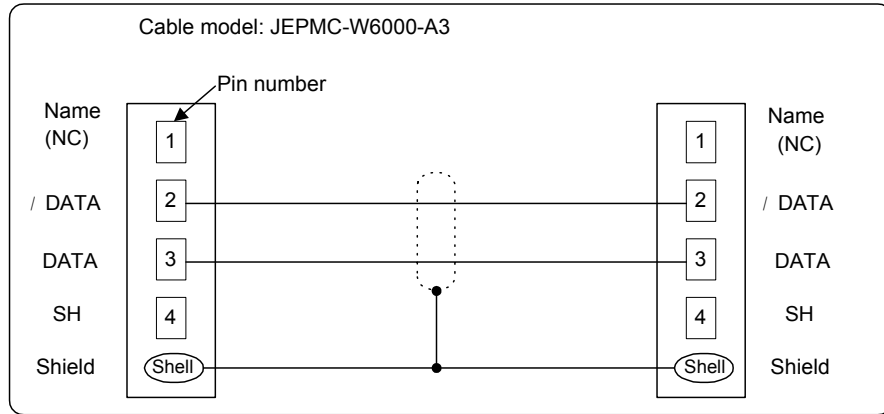

Note: Red lead: DATA; Black lead: /DATA

Table 5.4 USB Terminator Connection Diagram

MECHATROLINK Cable Appearance

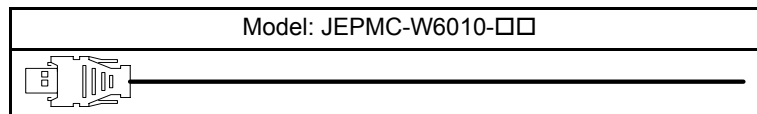
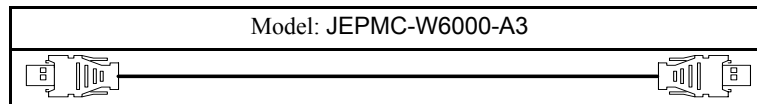

USB Terminator

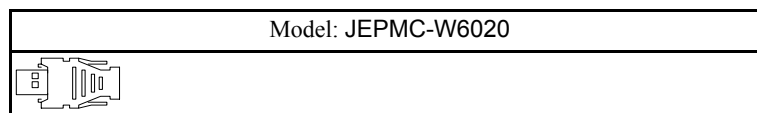

The connectors for MECHATROLINK 1 and 2 are exactly the same. You can insert the connector into either of them.

Insert a JEPMC-W6020 USB Terminator into any unused port.

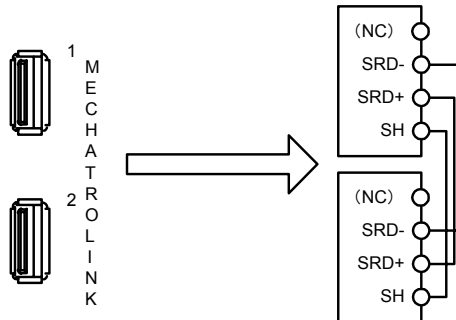

IMPORTANT

Only a single MECHATROLINK port can be used on the MP940 Module. There are two connector ports, but as the above diagram indicates, they are both the same.

■ Connecting MECHATROLINK

Connecting an IO350 Unit to an MP940 Module.

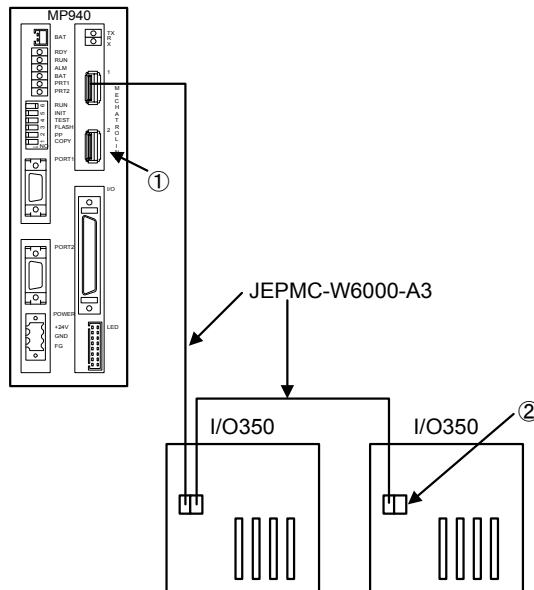

Use a JEPMC-W6000-A3 standard cable to connect an MP940 Module to an IO350 Unit, or an IO350 Unit to an IO350 Unit.

IMPORTANT

Be sure to insert a JEPMC-W6020 USB Terminator into the connector terminals (1. and 2. in the above diagram). Refer to the section on cables for appearance and internal connection diagrams.

5.4 Connecting Peripheral Devices

A standard connection example for MP940 and SGDH SERVOPACK is shown below.

5.4.1 Single Phase Power Supply Specifications

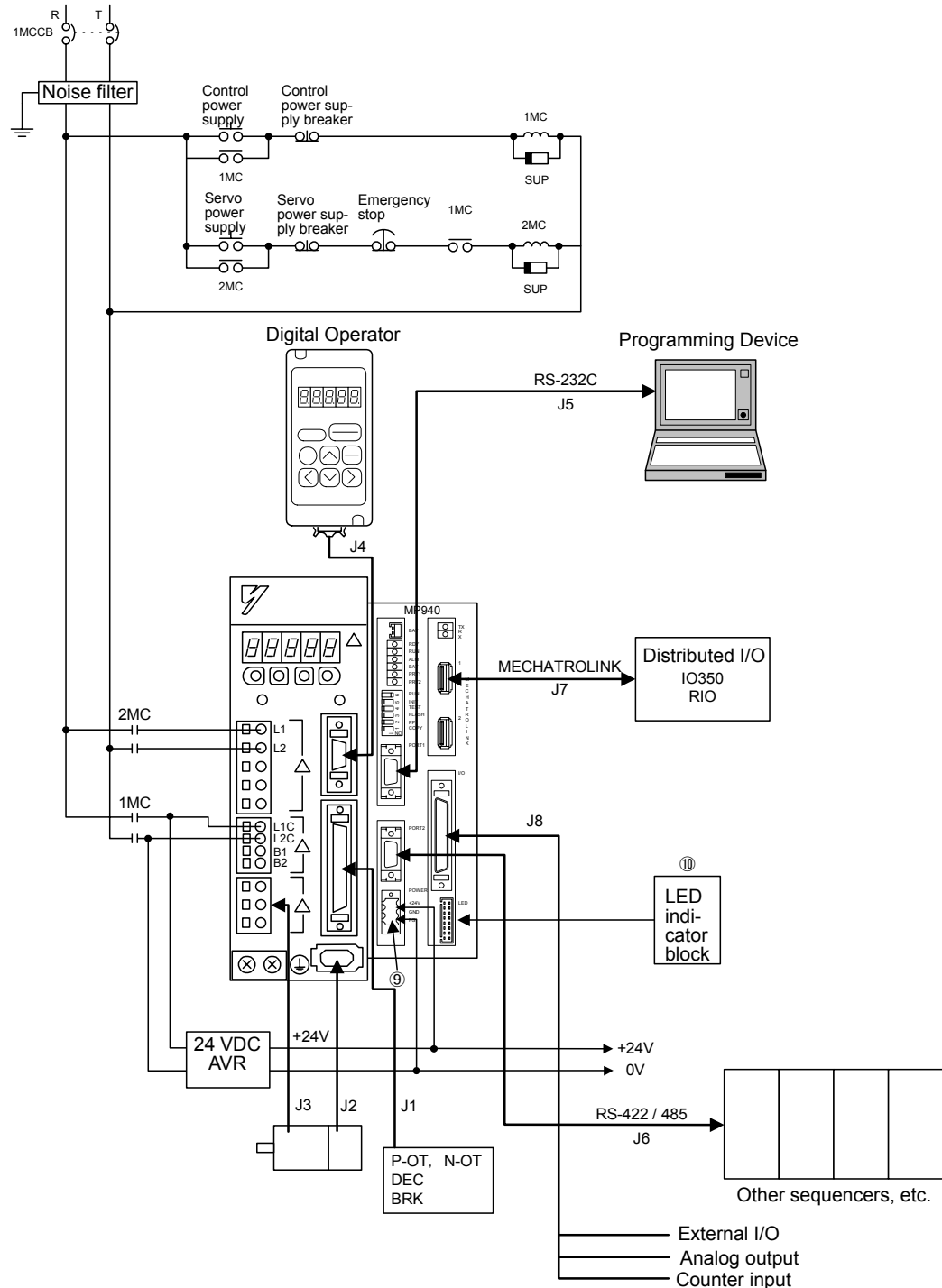

5.4.2 Three-phase Power Supply Specifications

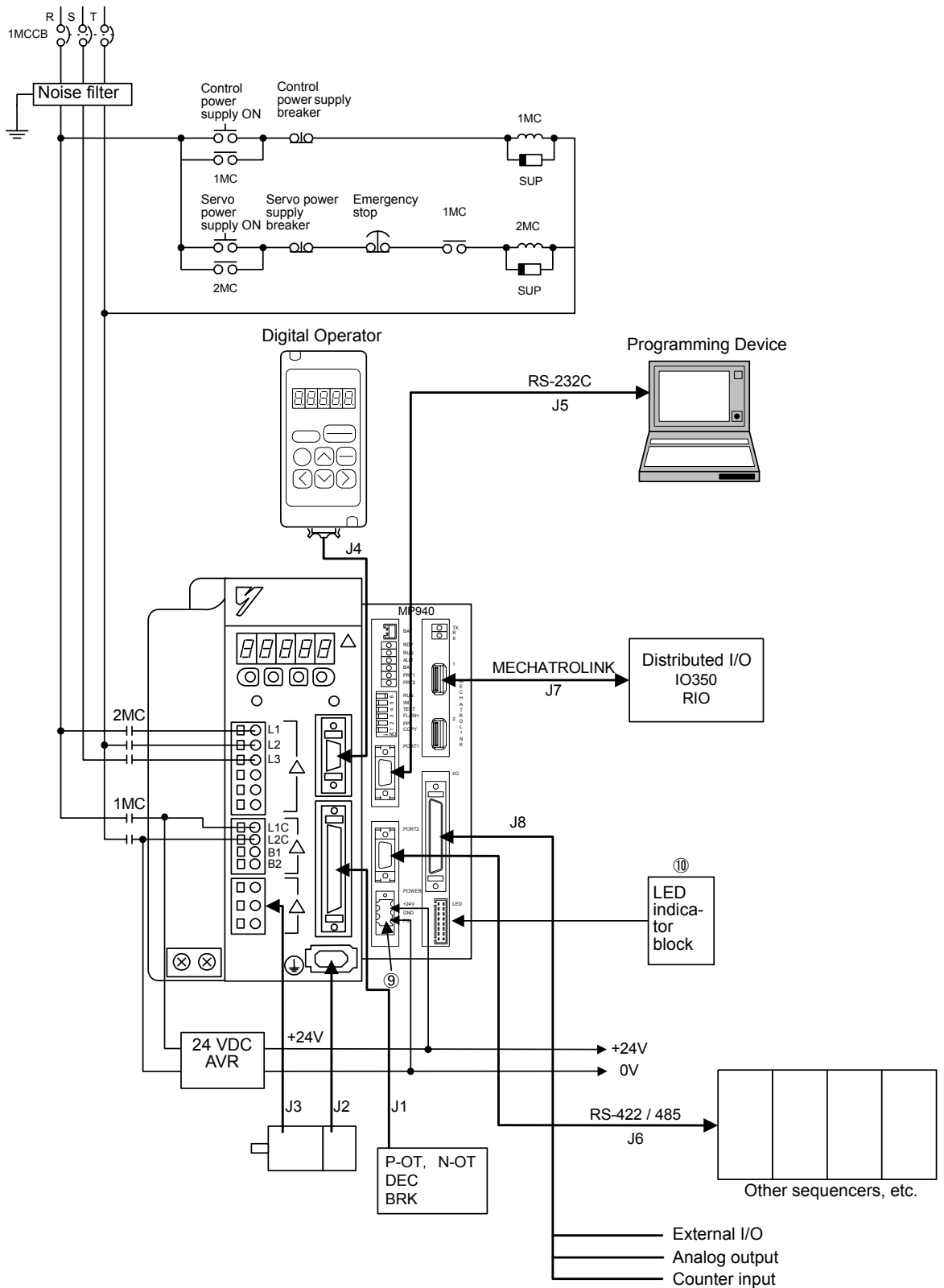

5.4.3 Standard Cable Table

Yaskawa provides the following standard cables.

Use these cables to connect the MP940 and external I/O devices, and to connect SERVOPACKs. The following table shows the cables required for configuring a system with MP940s.

■ SERVOPACK Cables

No.	Connector Name	Specifications	Model Number	Length
J1	CN1	I/O signal (CN1) connector cable 50-pin MDR with connector for SERVOPACK, loose wires at the other end	JZSP-CKI01-1	1 m
			JZSP-CKI01-2	2 m
			JZSP-CKI01-3	3 m
		Connector-Terminal Block Conversion Unit (0.5 m)	JZSP-TA50P	-
	Connector kits	Connector parts list (Sumitomo 3M) Connector: 10150-3000VE (×1) Case: 10350-52A0-008 (×1 set)	JZSP-CK19	-
J2	CN2	Encoder cable Connectors at both ends for SERVOPACK and encoder; for SGMGH or SGMSH Servomotors (with straight plug)	JZSP-CMP00-03	3 m
			JZSP-CMP00-05	5 m
			JZSP-CMP00-10	10 m
			JZSP-CMP00-15	15 m
			JZSP-CMP00-20	20 m
		Encoder cable Connectors at both ends for SERVOPACK and encoder; for SGMAH or SGMPH Servomotors (with L-shaped plug)	JZSP-CMP01-03	3 m
			JZSP-CMP01-05	5 m
			JZSP-CMP01-10	10 m
			JZSP-CMP01-15	15 m
			JZSP-CMP01-20	20 m
		Encoder cable Connectors at both ends for SERVOPACK and encoder	JZSP-CMP02-03	3 m
			JZSP-CMP02-05	5 m
			JZSP-CMP02-10	10 m
			JZSP-CMP02-15	15 m
			JZSP-CMP02-20	20 m
		Encoder cable Cable with connector for the SERVOPACK, and loose lead wires for the encoder	JZSP-CMP03-03	3 m
			JZSP-CMP03-05	5 m
			JZSP-CMP03-10	10 m
			JZSP-CMP03-15	15 m
			JZSP-CMP03-20	20 m

No.	Connector Name	Specifications	Model Number	Length	
J2	Cable materials	Standard cable (can be wired up to 20 m)	JZSP-CMP09-05	5 m	
			JZSP-CMP09-10	10 m	
			JZSP-CMP09-15	15 m	
			JZSP-CMP09-20	20 m	
		50-m specification cable (can be wired up to 50 m)	JZSP-CMP09-30	30 m	
			JZSP-CMP09-40	40 m	
	Connector kits	Encoder connector (CN2) plug for SERVOPACK Manufacturer's set model No.: 55100-0600 Manufacturer: MOLEX JAPAN CO., LTD.	JZSP-CMP09-1	-	
			Encoder connector socket for SGMAH and SGMPH servomotors Manufacturer's set model No.: 54280-0600 Manufacturer: MOLEX JAPAN CO., LTD.	JZSP-CMP09-2	-
J3	Motor cables	200 V: 30 W to 750 W 100 V: 30W to 200 W	Without brake	JZSP-CMM00-03	3 m
				JZSP-CMM00-05	5 m
				JZSP-CMM00-10	10 m
				JZSP-CMM00-15	15 m
				JZSP-CMM00-20	20 m
			With brake	JZSP-CMM10-03	3 m
				JZSP-CMM10-05	5 m
				JZSP-CMM10-10	10 m
				JZSP-CMM10-15	15 m
				JZSP-CMM10-20	20 m
		SGMPH-15: 1.5 kW	Without brake	JZSP-CMM20-03	3 m
				JZSP-CMM20-05	5 m
				JZSP-CMM20-10	10 m
				JZSP-CMM20-15	15 m
				JZSP-CMM20-20	20 m
			With brake	JZSP-CMM30-03	3 m
				JZSP-CMM30-05	5 m
				JZSP-CMM30-10	10 m
	JZSP-CMM30-15			15 m	
	JZSP-CMM30-20			20 m	
Connector kits	200 V: 30 W to 750 W 100 V: 30 W to 200 W	Without brake	JZSP-CMM9-1	-	
		With brake	JZSP-CMM9-2	-	
	SGMPH-15: 1.5 kW	Without brake	JZSP-CMM9-3	-	
		With brake	JZSP-CMM9-4	-	

No.	Connector Name	Specifications	Model Number	Length	
J4	CN3	Digital Operator (Digital Operator + Cable (1 m))	JUSP-OP02A-2	-	
		Cable only	JZSP-CMS00-1	1 m	
			JZSP-CMS00-2	1.5 m	
			JZSP-CMS00-3	2 m	
		Analog monitor cable	DE9404559	1 m	
		Absolute encoder battery	JZSP-BA01	-	
		Brake power supply	200-VAC power supply input	LPSE-2H01	-
			100-VAC power supply input	LPSE-1H01	-

■ MP940 Cables

No.	Connector Name	Specifications	Model Number	Length
J5	PORT1	RS-232C, MDR14-pin	JEPMC-W5314-03	3 m
			JEPMC-W5314-15	15 m
J6	PORT2	RS-422/485	Connector 10114-3000VE	-
			Shell 10314-52A0-008	-
J7	MECHA- TROLINK 1, 2	MECHATROLINK cable USB connectors at both ends	JEPMC-W6000-A3	0.3 m
			JEPMC-W6000-01	1 m
			JEPMC-W6000-03	3 m
			JEPMC-W6000-05	5 m
			JEPMC-W6000-10	10 m
			JEPMC-W6000-20	20 m
			JEPMC-W6000-30	30 m
		MECHATROLINK cable USB connector at one end, and loose wires at the other	JEPMC-W6010-07	7 m
			JEPMC-W6010-10	10 m
			JEPMC-W6010-15	15 m
			JEPMC-W6010-20	20 m
			JEPMC-W6010-30	30 m
			JEPMC-W6010-40	40 m
		USB terminator	JEPMC-W6020	-
J8	I/O	I/O connector	JZMSZ-120W0402-01	1 m
			JZMSZ-120W0402-03	3 m
			JZMSZ-120W0402-05	5 m
(9)	POWER	24-VDC connector	3L3.5/3F-AU	-
(10)	LED	I/O monitor LED indicator block (option)	-	-

5.5 SERVOPACK Main Circuit Connection

5.5.1 Names and Descriptions of Main Circuit Terminals

The following table provides the names and a description of main circuit terminals.

Table 5.5 Main Circuit Names and Description

Terminal Symbol	Name	Description	
L1, L2 or L1, L2, L3	Main circuit AC input terminal	30 W to 200 W	Single-phase 100 to 115 V +10%, -15% (50/60 Hz)
		30 W to 400 W	Single-phase 200 to 230 V +10%, -15% (50/60 Hz)
		0.5 kW to 7.5 kW	Three-phase 200 to 230 V +10%, -15% (50/60 Hz)
U, V, W	Servomotor connection terminal	Connects to the Servomotor.	
L1C, L2C	Control power input terminal	30 W to 200 W	Single-phase 100 to 115 V +10%, -15% (50/60 Hz)
		30 W to 7.5 kW	Single-phase 200 to 230 V +10%, -15% (50/60 Hz)
 (2 places)	Ground terminal	Connects to the power supply ground terminals and motor ground terminal.	
B1, B2 or B1, B2, B3	External regenerative resistor terminal	30 W to 40 W	Normally not connected. Connect an external regenerative resistor (provided by customer) between terminals B1 and B2 if the regenerative capacity is insufficient.*1
		0.5 kW to 5.0 kW	Normally short terminals B2 and B3 (for an internal regenerative resistor). Remove the wire between terminals B2 and B3 and connect an external regenerative resistor (provided by customer) between terminals B1 and B2 if the capacity of the internal regenerative resistor is insufficient.
		6.0 kW, 7.5 kW	Connect an external regenerative resistor (provided by customer) between terminals B1 and B2.*1
$\oplus 1, \oplus 2$ *2	DC reactor terminal connection for power supply harmonic wave countermeasure	Normally short $\oplus 1$ and $\oplus 2$. If a countermeasure against power supply harmonic waves is needed, connect a DC reactor between $\oplus 1$ and $\oplus 2$.	
\oplus *3	Main circuit plus terminal	Normally not connected.	
\ominus	Main circuit minus terminal	Normally not connected.	

* 1. No B3 terminal.

* 2. These terminals do not exist on SERVOPACKs with a capacity of 6 kW or higher.

* 3. This terminal is on SERVOPACKs with a capacity of 6 kW or higher only.

5.5.2 Typical Main Circuit Wiring

The following diagram shows a typical wiring example.

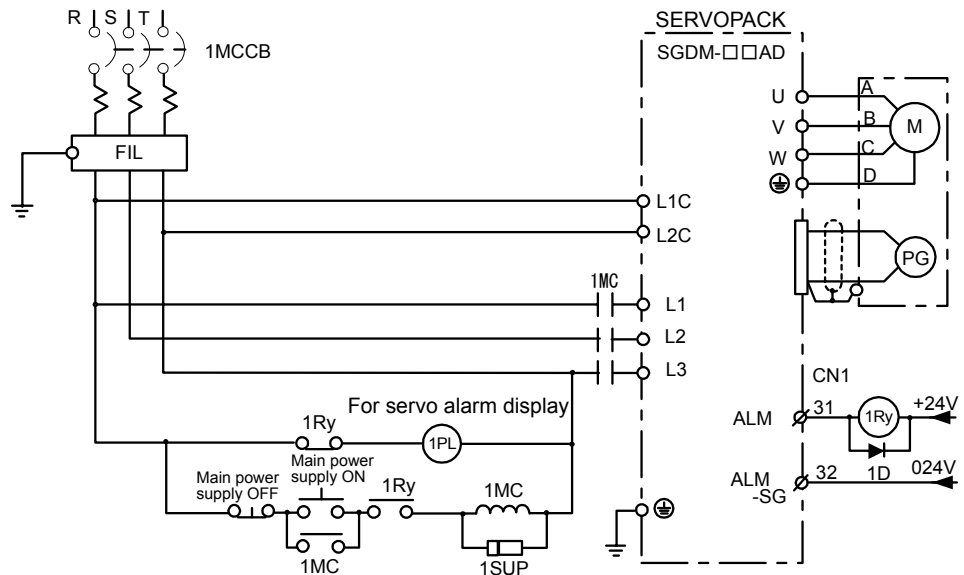

- 1MCCB: Molded-case circuit breaker (for the inverter)
- FIL: Noise filter
- 1MC: Magnetic Contactor
- 1Ry: Relay
- 1PL: Indicator lamp
- 1SUP: Surge suppressor
- 1D: Flywheel diode

■ Designing a Power ON Sequence

Note the following points when designing the power ON sequence.

- Design the power ON sequence so that power is turned OFF when a servo alarm signal is output. (See the circuit figure above.)
- Hold the power ON button for at least two seconds. The SERVOPACK will output a servo alarm signal for two seconds or less when power is turned ON. This is required in order to initialize the SERVOPACK.

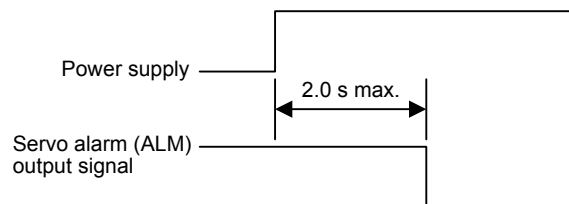

5.5.3 Wiring Main Circuit Terminal Blocks

Caution

- Remove the terminal block from the SERVOPACK prior to wiring.
- Insert only one wire per terminal on the terminal block.
- Make sure that the core wire is not electrically shorted to adjacent core wires.
- Strip the end of the wire again before reconnecting any wires that were accidentally pulled out.

SERVOPACKs with a capacity below 1.5 kW will have connector-type terminal blocks for main circuit terminals. Follow the procedure below when connecting to the terminal block.

■ Connection Procedure

1. Strip the end of the wire.

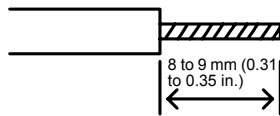

2. Open the wire terminal on the terminal block housing (plug) with the tool using the either of the following two procedures.

- Insert the hook end of the provided tool into the slot as shown in Fig. A.
- Use a standard screwdriver (blade width of 3.0 to 3.5 mm (0.12 to 0.14 in)) or a 210-120J screwdriver manufactured by WAGO. Put the blade into the slot, as shown in Fig. B, and press down firmly to open the wire terminal.

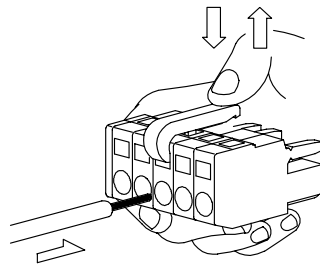

Fig. A

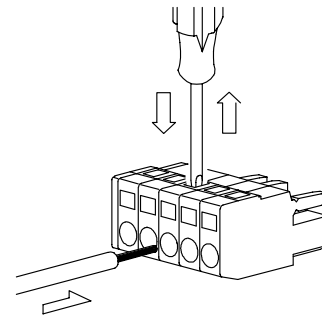

Fig. B

3. Insert the wire core into the opening and then close the opening by releasing the lever or removing the screwdriver.

■ Preparing the End of the Wire

Wire can be used simply by stripping back the outer coating. The following are applicable wire sizes.

- Single wire: Ø0.5 to Ø1.6 mm
- Braided wire: AWG28 to AWG12

5.6 SERVOPACK I/O Signals

This section describes I/O signals for the SGDH SERVOPACK.

5.6.1 Examples of I/O Signal Connections

The following diagram shows a typical example of I/O signal connections.

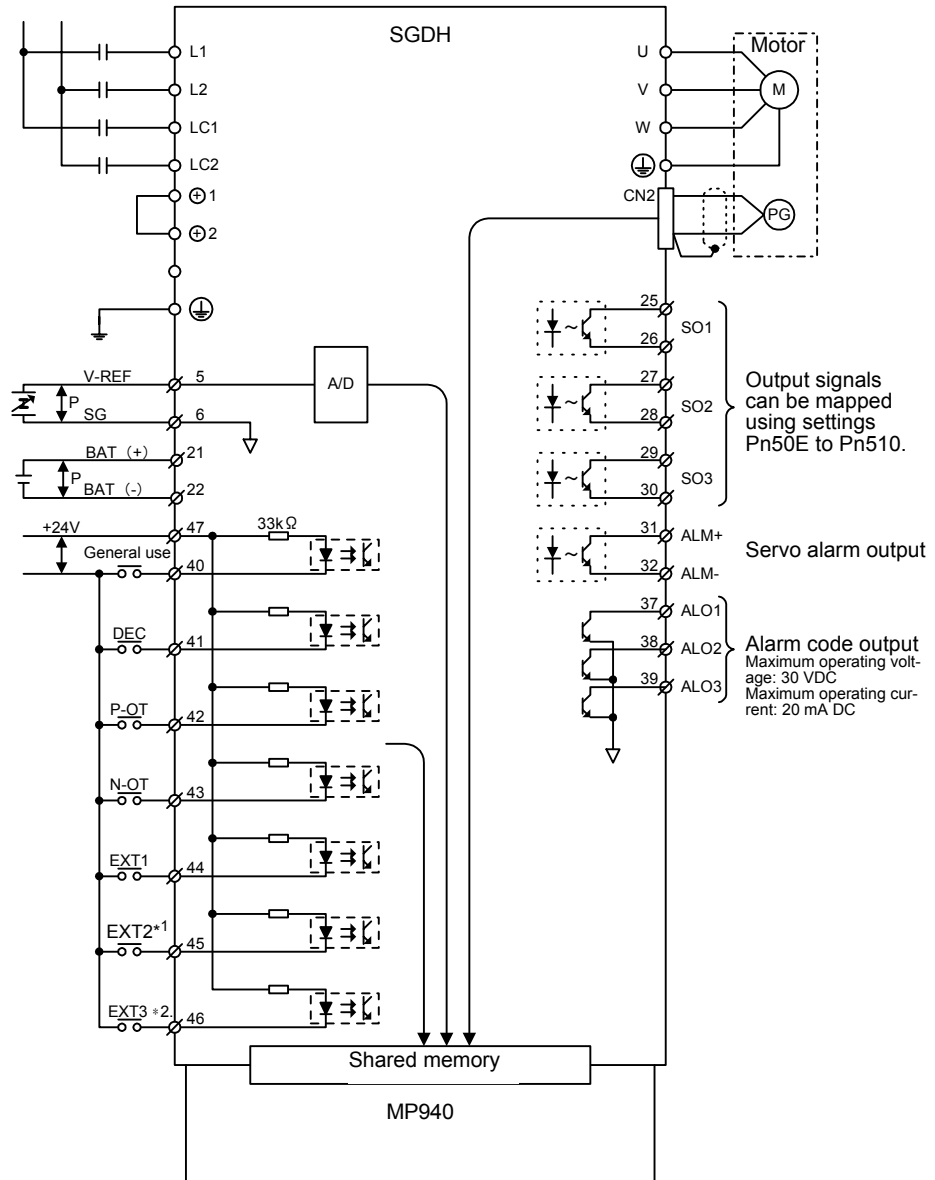

* 1. If using the ZERO signal for zero point return, connect the ZERO signal to EXT2.

* 2. Use EXT3 as the latch input signal.

5.6.2 List of CN1 Terminals

The following diagram shows the layout and specifications of CN1 terminals.

■ CN1 Terminal Layout

2	SG	GND	1	SG	GNC	26	/V-CMP- (/COIN-)	Speed coinci- dence detec- tion output
4	-	-	3	-	-	27	/TGON+	TGON sig- nal output
6	SG	GND	5	V-REF	General AI	28	/TGON-	TGON signal output
8	-	-	7	-	-	29	/S- RDY+	Servo ready output
10	-	-	9	-	-	30	/S-RDY-	Servo ready output
12	-	-	11	-	-	31	ALM+	Servo alarm output
14	-	-	13	-	-	32	ALM-	Servo alarm output
16	-	-	15	-	-	33	-	-
18	-	-	17	-	-	34	-	-
20	-	-	19	-	-	35	-	-
22	BAT (-)	Battery (-)	21	BAT (+)	Battery (+)	36	-	-
24	-	-	23	-	-	37	AOL1	Alarm code output
			25	/V-CMP+ (/COIN+)	Speed coinci- dence detec- tion output	38	ALO2	Alarm code output
						39	ALO3	Alarm code output
						40	SIO	General input
						41	/DEC-	Deceleration LS for zero point return
						42	P-OT	Forward over- travel input
						43	N-OT	Reverse overtravel input
						44	/EXT1	External latch signal 1 input
						45	/EXT2	External latch signal 2 input
						46	/EXT3	External latch signal 3 input
						47	+24V -IN	External input power supply
						48	-	-
						49	-	-
						50	-	-

Note: 1. Do not use unused terminals for relays.

2. Connect the shield of the I/O signal cable to the connector shell. Connect to the FG (frame ground) at the SERVOPACK-end connector.

■ CN1 Specifications

Specifications for SERVOPACK Connectors	Applicable Receptacles		
	Solder Type	Case	Manufacturer
10250-52A2JL or Equivalent 50-pin Right Angle Plug	10150-3000VE	10350-52A0-008	Manufactured by Sumitomo 3M Ltd.

5.6.3 I/O Signal Names and Functions

The following tables describe SERVOPACK I/O signal names and functions.

■ Input Signals

Signal Name	Pin No.	Function		
Common	SIO	40	General input signal	
	/DEC	41	Deceleration limit switch signal for zero point return	
	P-OT	42	Forward Run prohibited	Overtravel prohibited: Stops servomotor when movable part travels beyond the allowable range of motion.
	N-OT	43	Reverse Run prohibited	
	/EXT1	44	External input signal 1	General input signal.
	/EXT2	45	External input signal 2	Used as latch detection signals. (If not using DI latch detection, EXT2 and EXT3 can be used as general input signals.)
	/EXT3	46	External input signal 3	
	+24VIN	47	Control power supply input for sequence signals: Users must provide the +24-V power supply.	
	BAT(+)	21	Connecting pin for the absolute encoder backup battery.	
BAT(-)	22			
Analog input	V-REF	5 (6)	Used as general analog input signal.	
	-	9 (10)	Do not use.	
		7 8 11 12 15 14 3 13 18	Do not use.	

Note: 1. The functions allocated to /S-ON, /P-CON, P-OT, N-OT, /ALM-RST, /P-CL, and /N-CL input signals can be changed via parameters. (See 5.3.3 *Input Circuit Signal Allocation* of Σ -II Series SGM□H/SGDH User's Manual Design and Maintenance (SIE-S800-32.2).

2. Pin numbers in parenthesis () indicate signal grounds.

3. The voltage input range for speed and torque references is a maximum of +12 V.

■ Output Signals

Signal Name		Pin No.	Function
Common	ALM+	31	Servo alarm: Turns OFF the servo when an error is detected.
	ALM-	32	
	/TGON+	27	Detection during servomotor rotation: Detects whether the servomotor is rotating at a speed higher than the motor speed setting. Motor speed detection can be set via parameter.
	/TGON-	28	
	/S-RDY+	29	Servo ready: ON if there is no servo alarm when the control/main circuit power supply is turned ON.
	/S-RDY-	30	
		33 (1) 34 35 36 19 20	Do not use.
		48 49	Do not use.
ALO1 ALO2 ALO3	37 38 39 (1)	Alarm code output: Outputs 3-bit alarm codes. Open-collector: 30 V and 20 mA rating maximum	
FG	Shell	Connected to frame ground if the shield wire of the I/O signal cable is connected to the connector shell.	
Speed	/V-CMP+ /V-CMP-	25 26	Speed coincidence (output in Speed Control Mode): Detects whether the motor speed is within the setting range and if it matches the reference speed value.
Reserved		16 17 23 24 50	These terminals are not used. Do not connect relays to these terminals.

Note: 1. Pin numbers in parenthesis () indicate signal grounds.

2. The functions allocated to /TGON, /S-RDY, and /V-CMP (/COIN) can be changed via parameters. /CLT, /VCT, /BK, /WARN, and /NEAR signals can also be changed. (See 5.3.4 *Output Circuit Signal Allocation* of Σ -II Series SGM□H/SGDH User's Manual Design and Maintenance (SIE-S800-32.2).

5.6.4 Interface Circuits

This section shows examples of SERVOPACK I/O signal connection to the host controller.

■ Interface for Reference Input Circuits

Analog Input Circuit

Analog signals are either speed or torque reference signals at the impedance below.

- Speed reference input: About 14 k Ω
- Torque reference input: About 14 k Ω

The maximum allowable voltages for input signals is ± 12 V.

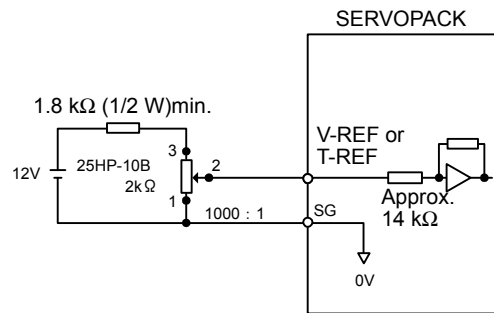

■ Sequence Input Circuit Interface

The sequence input circuit interface connects through a relay or open-collector transistor circuit. Select a low-current relay otherwise a faulty contact will result.

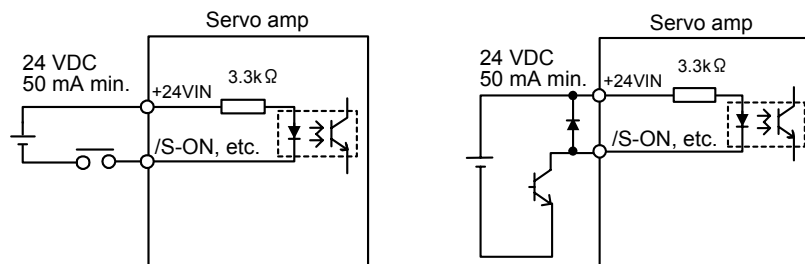

- Connecting to an Open-collector Output Circuit

Alarm code signals are output from open-collector transistor output circuits. Connect an open-collector output circuit through a photocoupler, relay, or line receiver circuit.

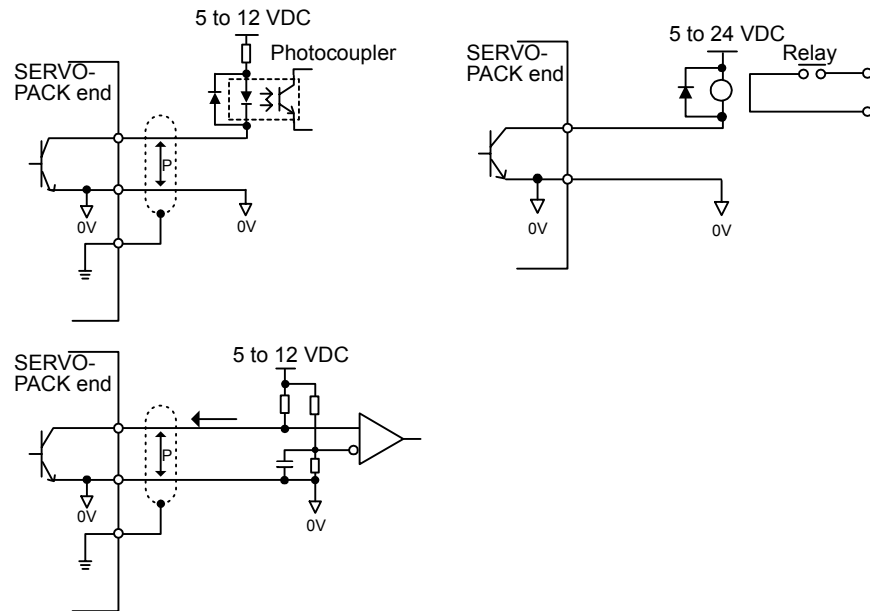

Note: The maximum allowable voltage and current capacities for open-collector output circuits are as follows.

Voltage: 30 VDC max.

Current: 20 mA DC max.

- Connecting to a Photocoupler Output Circuit

Photocoupler output circuits are used for servo alarm, servo ready, and other sequence output signal circuits.

Connect a photocoupler output circuit through a relay or line receiver circuit.

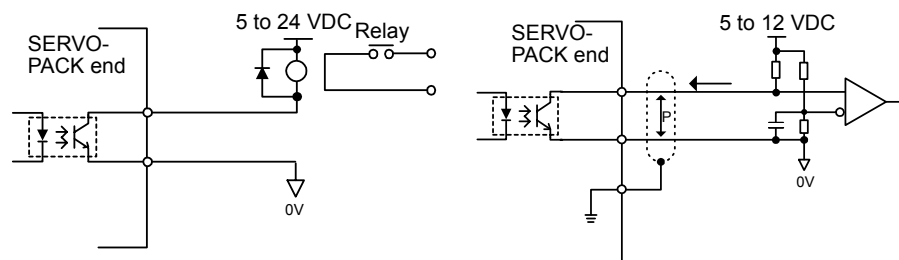

Note: The maximum allowable voltage and current capacities for photocoupler output circuits are as follows.

Voltage: 30 VDC max.

Current: 50 mA DC max.

5.7 Wiring Encoders

This section describes the procedure for wiring a SERVOPACK to the encoder.

5.7.1 Connecting an Encoder (CN2) and Output Signals from the SERVOPACK (CN1)

The following diagrams show wiring for incremental and absolute encoders.

■ Incremental Encoders

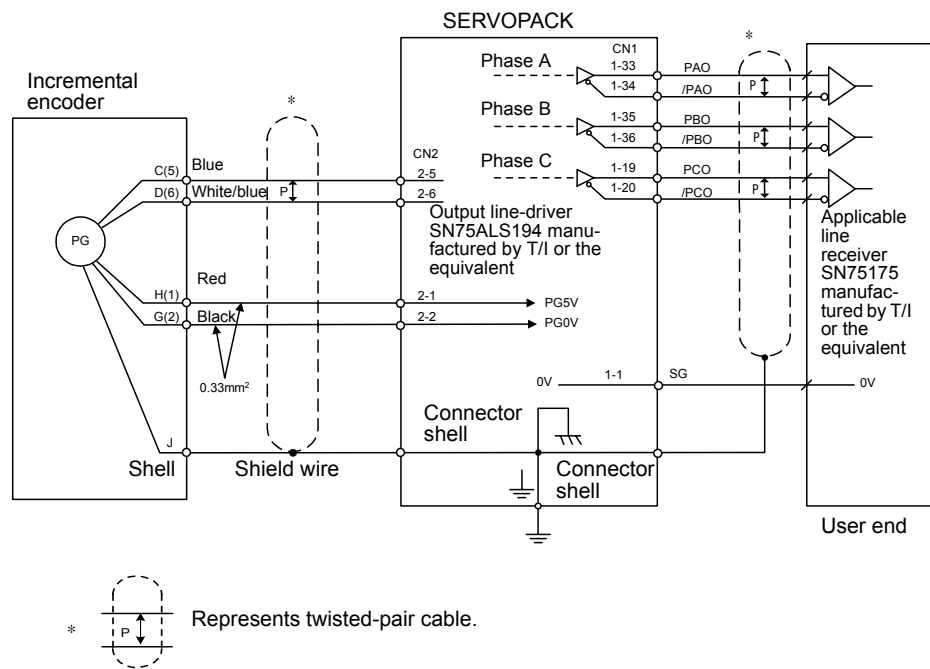

■ Absolute Encoders

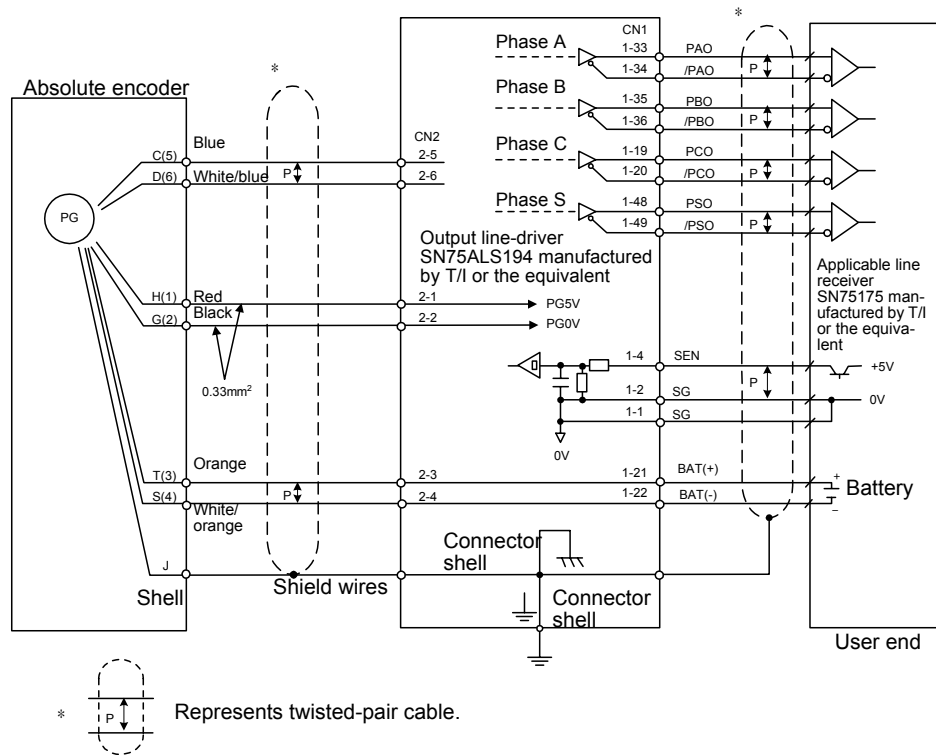

5.7.2 CN2 Encoder Connector Terminal Layout and Types

The following tables describe CN2 connector terminal layout and types.

■ CN2 Connector Terminal Layout

1	PG5V	PG power supply +5 V	2	PG0V	PG power supply 0 V
3	BAT(+)	Battery (+) (For an absolute encoder)	4	BAT(-)	Battery (-) (For an absolute encoder)
5	PS	PG serial signal input	6	/PS	PG serial signal input

■ CN2 Connector Models

SERVOPACK Connectors	Applicable Plug (or Socket)		
	Soldered Relay Plug (SERVOPACK Connector)	Soldered Relay Plug (Servomotor Connector)	Manufacturer
53460-0611	55100-0600	54280-0600	Molex Japan Co., Ltd.

-
- Note: 1. FA1394 is the product number for the SERVOPACK-end plug and the Servomotor-end socket set from Molex Japan Co., Ltd.
2. The Servomotor-end relay socket connects to the encoder connector for the SGMAH and SGMPH Servomotors.
3. The following encoder connectors are for the SGMGH and SGMSH Servomotors.
- L-shaped plug: MS3108B20-29S or
Straight: MS3106B20-29S
Cable clamp: MS3057-12A
-



Encoder cables are available from Yaskawa. See the data sheets below for more details on the cables.

- Refer to *Σ-II Series SGM□H/SGDM User's Manual Servo Selection and Data Sheets* (Manual No.: SIE-S800-31.1).
-

5.8 System Startup

This section explains the procedure when a Test System is used for positioning control. Consult the relevant reference manuals for the various procedures required. Details of the machine system design have been omitted here.

5.8.1 Overview of the Startup Procedure

The system startup procedure is as follows:

1. Prepare the equipment to be used.
Prepare the equipment to be used by referring to *5.8.2 Test System Configuration* and *5.8.4 Equipment Preparations*.
2. Mount the Units.
Mount the MP940 Module on the SGD H SERVOPACK.
3. Connect and wire the system.
Connect the Programming Device, and wire the external I/O signals, servomotor, and SERVOPACK.
4. Start the Programming Device.
Prepare the system definitions, such as the Module definitions, group definitions, and scan time settings.
5. Set and save the parameters.
Use the Programming Device to set the machine parameters for testing.
6. Create, save, and transfer a motion program.
Use the Programming Device to create the motion program for testing.
7. Transfer definitions, parameters, and programs
8. Check operation.
Execute the program and check the test operation.

5.8.2 Test System Configuration

The following illustration shows the Test System configuration.

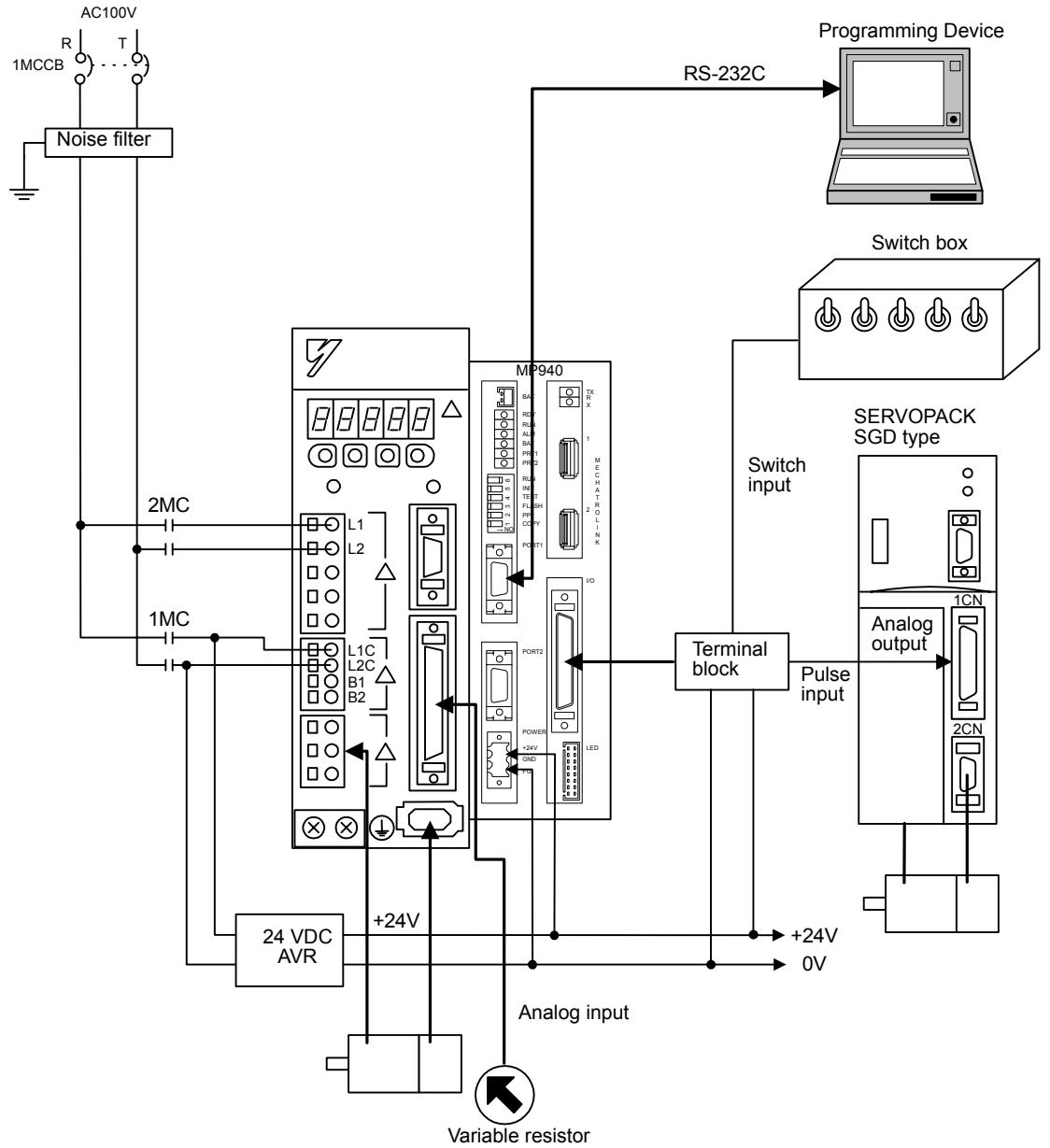

5

5.8.3 Test System Outline

■ Control Outline

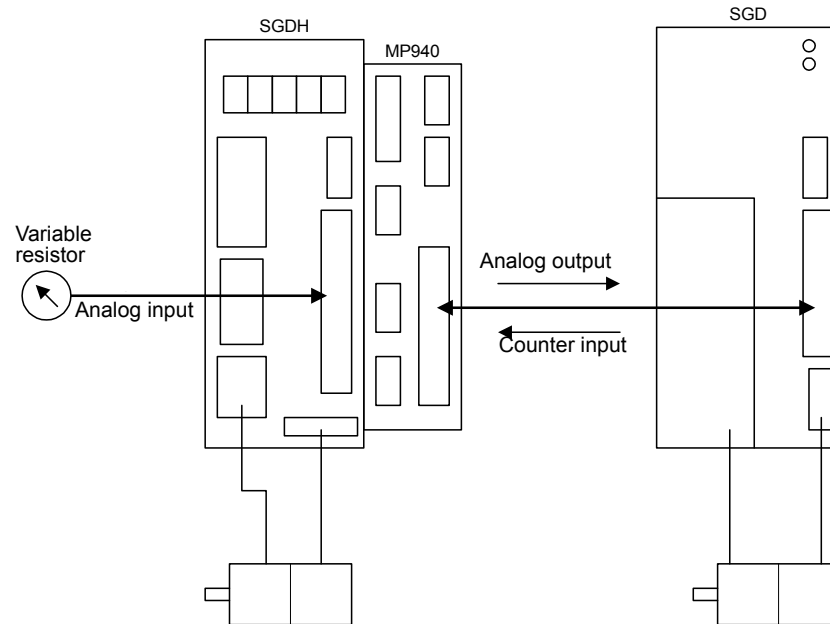

■ Operation Outline

1. The value of the variable resistor connected to the SGD Servopack analog input terminal is read to the MP940.
2. An output based on the value read from the variable resistor is output to the SERVOPACK connected to the analog output (AO) to turn the motor.
3. The encoder pulses for the motor driven in step 2 are read using the MP940 counter, and the servomotor connected to the SGD Servopack is moved by the number of pulses read every scan cycle.

5.8.4 Equipment Preparations

Prepare the equipment shown in the following tables.

■ Controller-related Equipment

Name	Model
MP940	JEPMC-MC400
I/O Signal Cable	JZMSZ-120W0402-10
Connector-Terminal Block Conversion Unit (terminal block + connection cable)	JZSP-TA50P

■ Servo-related Equipment

Name	Model
SGDH SERVOPACK	SGDH-A5BE
Servomotor	SGMAH-A5B
Motor Cable	JZSP-CMM00-03
PG Cable	JZSP-CMP00-03
SGD SERVOPACK	
Servomotor	
Motor Cable	
PG Cable	

5

■ Programming Device-related Equipment

Name	Model
Personal Computer	Windows 95 or Windows NT
Software	CP-717 Ver.3.5x
MEMOBUS Cable	JEPMC-W5314-03

■ Other Required Equipment

Name	Model
Switch box	-
24-VDC power supply (AVR)	-
12-VDC power supply	-
No-fuse breaker	-
Switches	-
Variable resistor	-
Wiring material	-

5.8.5 Mounting the MP940 Module

Use the following procedure to mount the MP940 Module to the SGD_H SERVOPACK.

1. Insert the two protrusions on the bottom of the MP940 into the mounting holes on the lower right of the SERVOPACK.

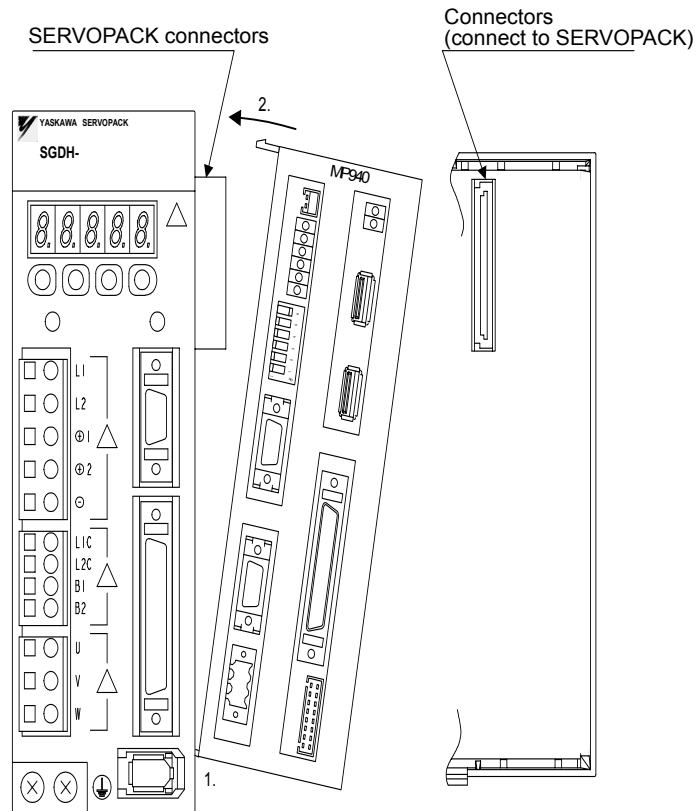

2. Push the MP940 in the direction of the arrows, and insert the top protrusion in the upper mounting holes on the right of the SERVOPACK.
3. Insert the spring (see next page) for securing the MP940 Module into the holes on the top of the SERVOPACK.

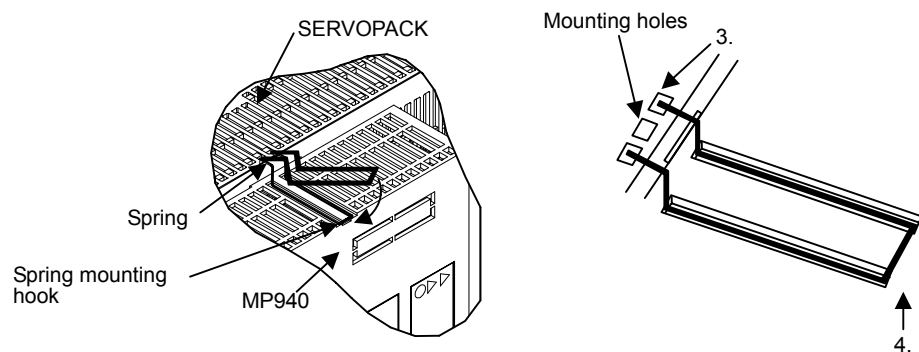

4. Pull the mounting spring and hook it to the spring mounting hook on the top of the MP940 case.
5. Mount the bottom springs using the same procedure as step 4.

■ Type of Spring

There are two types of mounting springs, and the shape of the spring differs depending on the SERVOPACK capacity. Refer to the following when mounting.

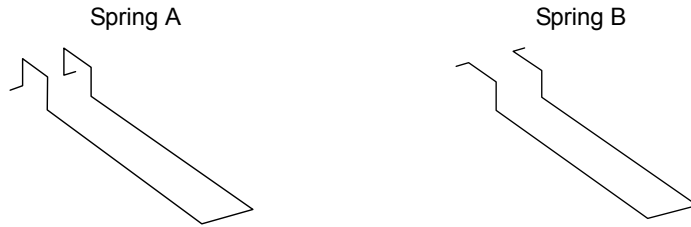

SERVOPACK Type	Mounting Springs	Locations
SGDH-A3 SGDH-A5 SGDH-01 SGDH-02 SGDH-04 SGDH-05 SGDH-08 SGDH-10 SGDH-15 SGDH-20 SGDH-30 SGDH-50	Top: Spring A Bottom: Spring A	
SGDH-20 SGDH-30 SGDH-50	Top: Spring A Bottom: Spring B	

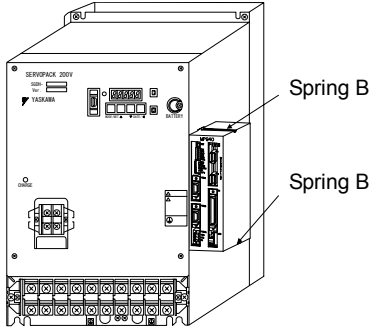
SERVOPACK Type	Mounting Springs	Locations
SGDH-60 SGDH-75	Top: Spring B Bottom: Spring B	

5.8.6 Mounting the Battery Holder

The procedure for mounting the MP940 battery holder is explained below.

1. Insert the battery holder into the (top) battery holder mounting holes on the MP940.
2. With the battery holder clipped in place in the top battery mounting holes, press and lift up on the holder clip and insert the hooks into the bottom mounting holes.

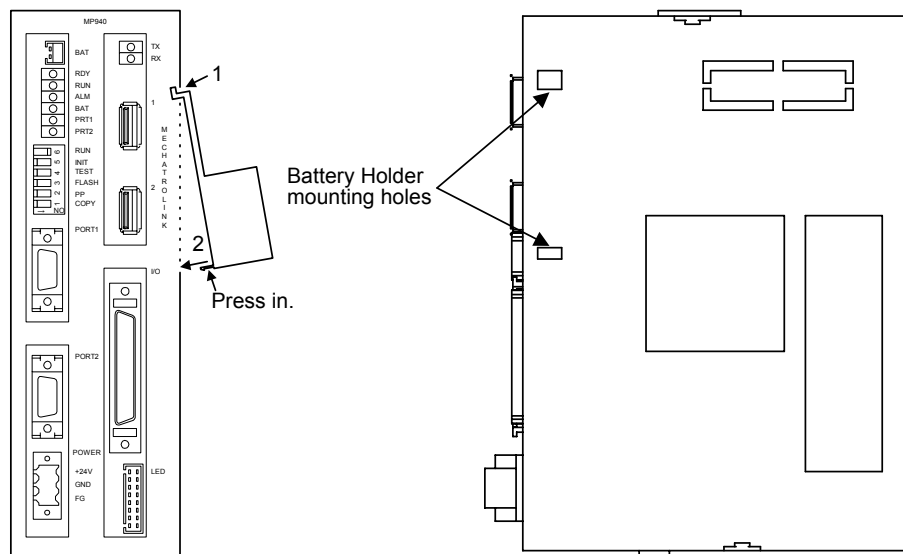

3. Push down the holder, and make sure that it is firmly inserted.

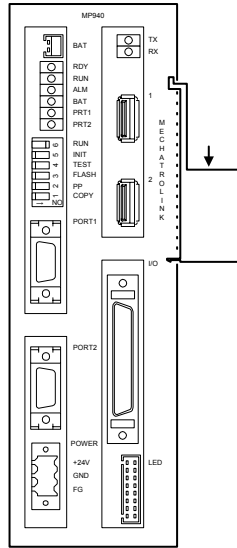

5.8.7 Connections and Wiring

■ Connecting External Devices

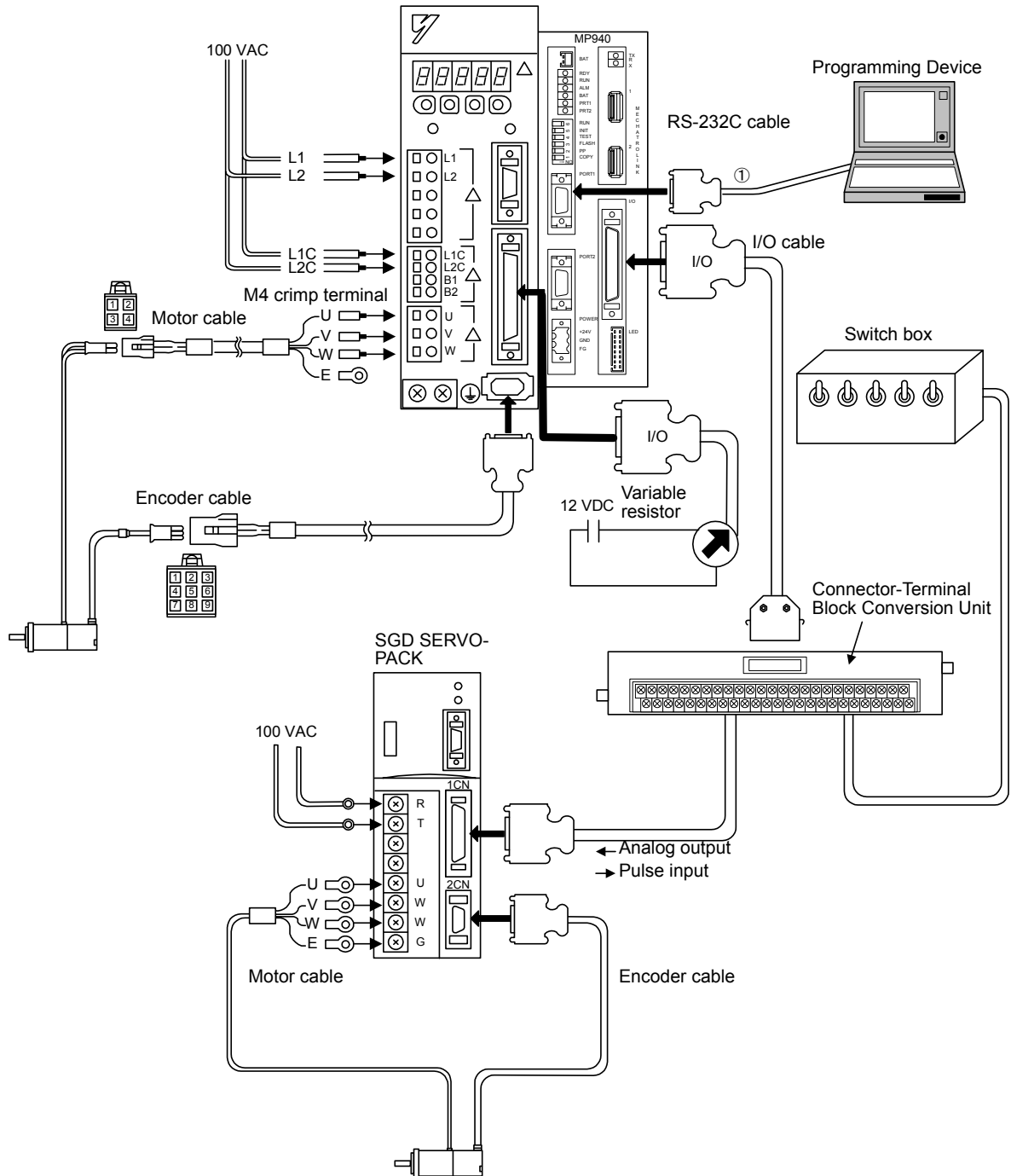

■ Operation Using MP940 Analog Output

SERVOPACK (SGD) to Switch Box Connections

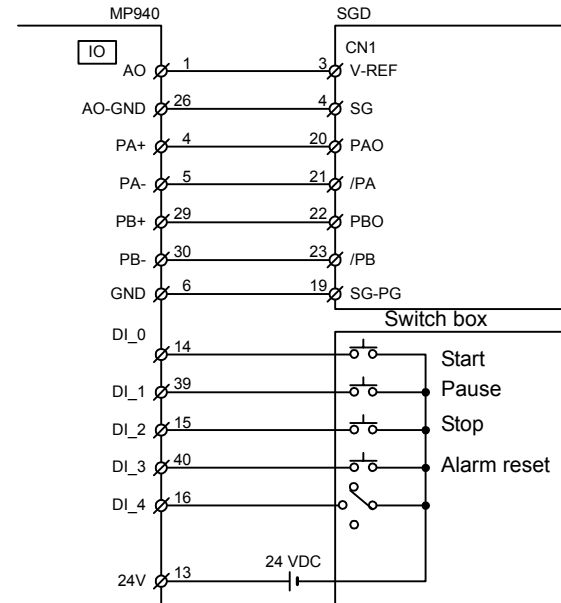

■ Connecting a Variable Resistor to the V-REF Terminal of the SGDH SERVOPACK as a General AI Input

5

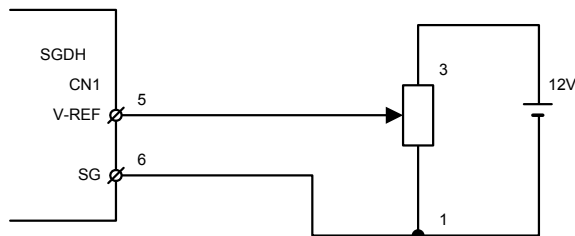

5.8.8 MP940 Initialization

The initialization procedure when mounting an SGDH SERVOPACK to the MP940 is shown below.

1. Mount the MP940 to the SGDH SERVOPACK.
Refer to *5.8.5 Mounting the MP940 Module*.
2. Wire and check the cables.
Refer to *5.8.7 Connections and Wiring*.
3. Clear the MP940 memory using the DIP switch (turn ON INIT and TEST only).
Refer to *Memory Initialization* in *3.2.1 DIP Switch Settings*.
4. Turn ON the power to the SGDH SERVOPACK and MP940.

5. Initialize the SGD_H SERVOPACK using Fn0014, Fn0005, and Fn0006.
This procedure is for confirmation and it is not necessary if initialization has been performed from the servo.
6. Check that the MP940 memory has been cleared (RDY and RUN indicators should be lit).
The memory will be cleared the next time the power supply is turned ON.
7. Set the MP940 DIP switch to normal operation (turn ON only RUN).
8. Turn OFF the power supply to the SGD_H SERVOPACK and MP940 and then ON again.
9. Start the CP-717.
Connect online to the MP940.
Refer to 5.8.9 *Starting the CP-717*.
10. Open the MP940 Module configurations.
11. Change the SGD_H SERVOPACK Pn parameters for the MP940.
Open SERVOPACK in the SVA Module, and select **Edit (E)** and then **Default Settings (R)** from the menus.
The Digital Operator can also be used. Refer to 4.7.4 *Setting Parameters of the SGD_H SERVOPACK*.
12. Change the SERVOPACK parameters.
Pn50A: 2881H to 8881H
Pn50B: 8883H to 8888H
Disable P-OT and N-OT.
13. Save SERVOPACK data.
14. Turn OFF the power to the SGD_H SERVOPACK and MP940, and then ON again.
15. Check that “bb” is displayed on the SGD_H SERVOPACK, and that the RDY and RUN indicators are lit on the MP940.

5.8.9 Starting the CP-717

This section explains the Modules configuring the MP940, the module configuration definitions for I/O allocation, and the methods of setting group definitions for the number of axes and tasks. Be sure to set these when the system is first started up.

■ Procedure for Starting the CP-717

Make sure the CP-717 System Software is installed in advance.

The following is an overview of the CP-717 startup procedure.

1. Create a Group Folder.
2. Create an Order Folder.
3. Create a Controller Folder.
4. Logon offline.
5. Set the Module Configuration Definitions.
6. Set the Group Definitions.
7. Set the Scan Time.

■ Creating a Group Folder

Start the CP-717, and create a Group Folder using the File Manager Window.

- Example: File name = AAA

The procedure for creating group folders is given below.

1. Point the cursor to *root*, click the right mouse button, and select *New (N)* and then *Group Folder (G)*.

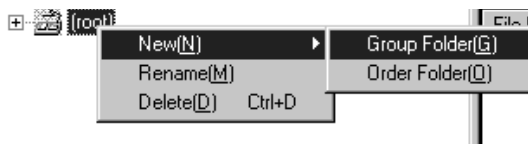

2. Input the group folder name in the dialog box, and then click the **OK** Button.

The group folder name must be eight characters or less.

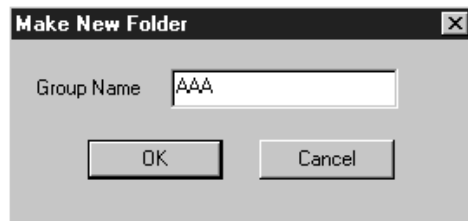

- The group folder (here, “AAA”) will be created. Double-click *root* or click the  icon. The AAA Group Folder will be displayed.

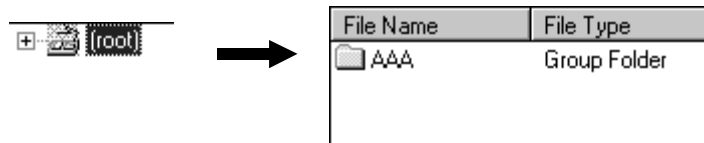

■ Creating an Order Folder

The procedure for creating an order folder is shown below.

- Point to *root*, click the right mouse button, and click *New (N)* and then *Order Folder (O)*.

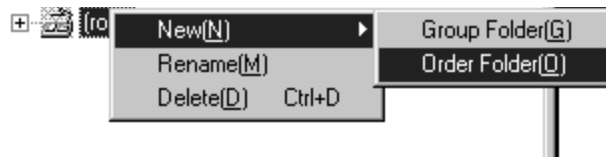

- In the dialog box, input the order folder name and click the *OK* Button. The order folder name must be eight characters or less.

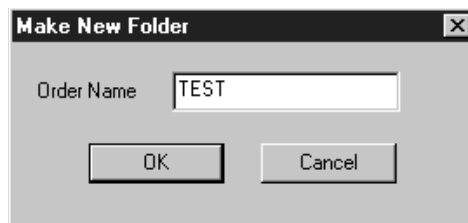

- The new “TEST” order folder will be created. Double-click *root* or click the  icon. The TEST folder will be displayed.

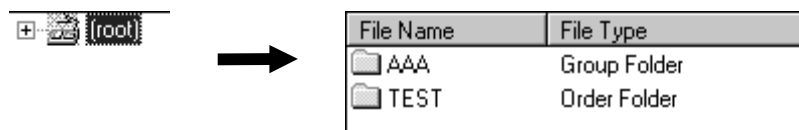

■ Creating a Controller Folder

Register the new Controller to be used to create the program.

Example: Controller name = MP940

Controller type = MP940

The procedure for creating the Controller Folder is given below.

1. Point to the TEST order folder, click the right mouse button, and click **Make New Folder (N)** and then **Controller Folder (C)**.



2. In the Controller Configuration Window, set the Order Name and Controller Type, and then click the **OK** Button.

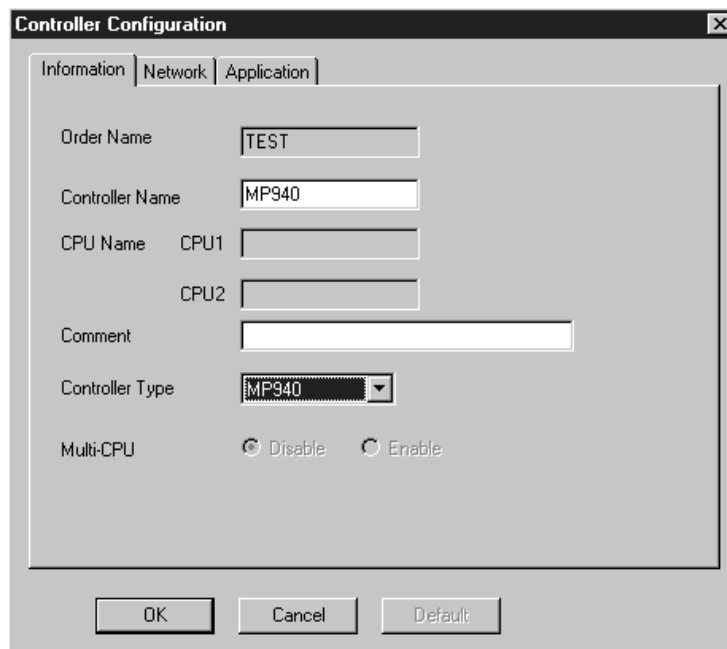

3. The new Controller Folder (MP940) will be created. Double-click the Order Folder TEST, or click the  icon. The Controller name MP940 will be displayed.



■ Logging On Offline

To create a Controller program or definition data, you must log onto the Controller. The procedure for logging on to the Controller folder is explained below.

1. Point the cursor to the Controller Folder MP940, click the right mouse button, and then click **Online (O)** to log on.

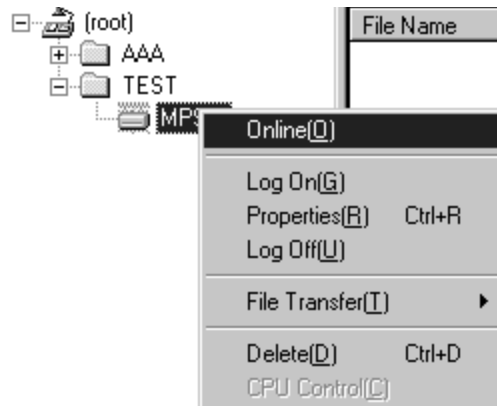

2. Point the cursor to Controller Folder MP940, click the right mouse button, check that you are in online mode, and then either select **Log On (G)** from the pop-up menu, or double-click Controller Folder MP940.

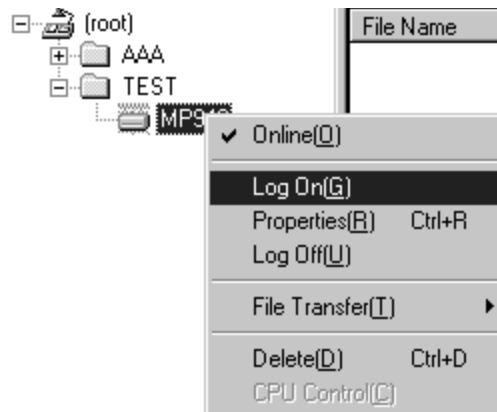

3. Input the user name and password, and click the **OK** Button.

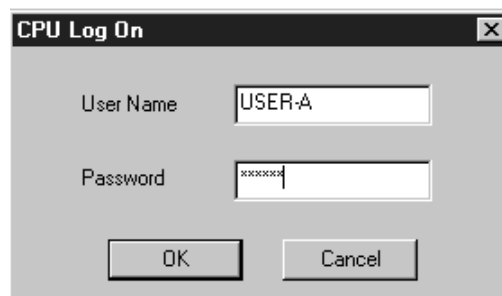

- The Definition, Programs, Table Data, and C Register Folders will be displayed in the MP940 Controller folder. This completes the logon procedure.

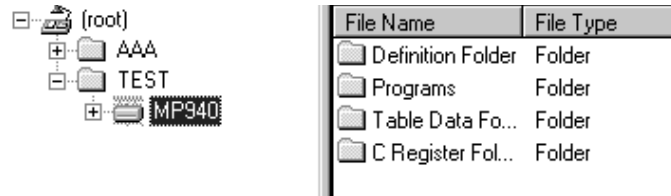

■ Module Definitions

Set the basic parameters for the serial, LIO, SVA, CNTR, and MLINK functions built into the MP940.

- Double-click **Module Configuration**, which opens in the folder in the tree for the MP940 Controller Folder.

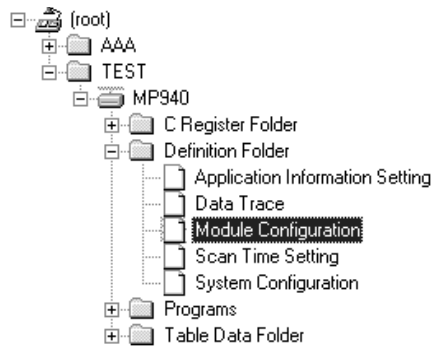

5



If you open the Module Configuration Window before any settings have been made, the New Message Box will be displayed. Click the **OK** Button, and then perform the following operation.

- The Main Module Configurations Window will be displayed. With the MP940, you can only change Rack 1 and Short. You cannot change function modules allocated to slots 00 to 06.

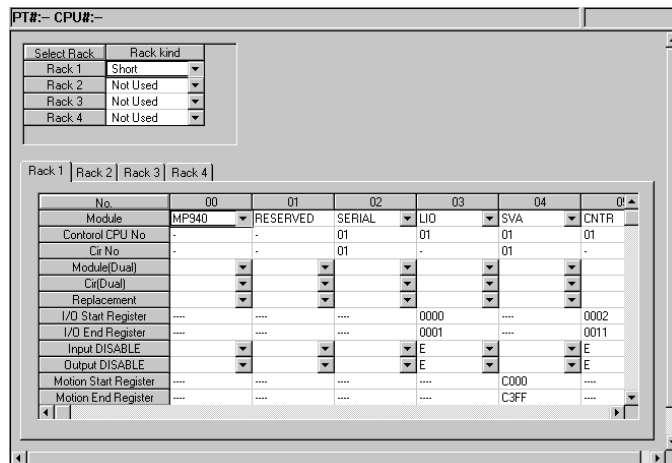

■ LIO Definitions

1. Double-click **LIO** in slot 3.

If no module configurations have been saved, the Save Module Configuration Message Box will be displayed. Click the **Yes (Y)** Button, and then perform the following operation.

The default module configuration value will be transferred to the MP940. The Main Module Configuration Window status will change from Operating to Waiting to Initialize.

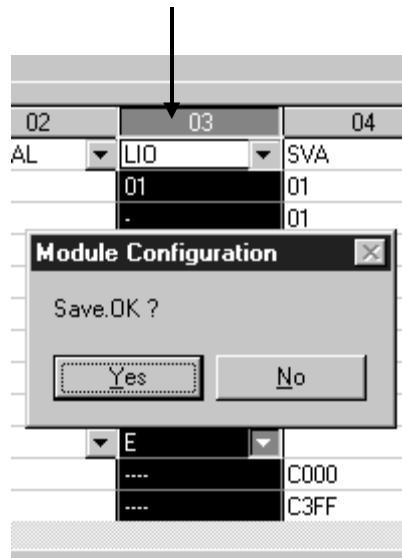

2. If no configurations have been saved, the New File Message Box will be displayed. Click the **OK** Button, and then perform the following operation.

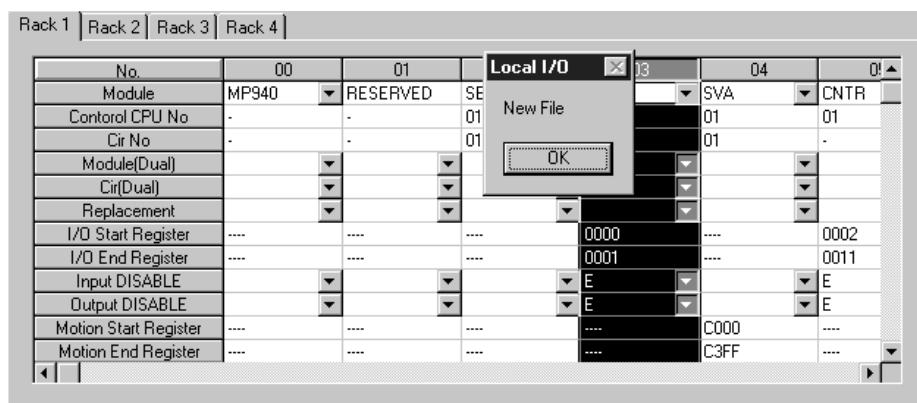

- Using the Local I/O Definition Window, you can change only the SCAN settings. You cannot set REG-No. Make these settings using the I/O leading register number/I/O end register number in the Module Configuration Window.

PT#:- CPU#:-		RACK#01 SLOT#03 0000-0001							
No.	Item	Operation	D	REG-No	Word	SCAN	Current Value	Unit	HE
01	Discrete Input	-	<input type="checkbox"/>	Iw0000	1	HIGH			
02	Discrete Output	-	<input type="checkbox"/>	0w0000	1	HIGH			
03	Interruption Input	Unused	<input type="checkbox"/>	IB00000	-				
04	Analog Input	-15 - +15V	<input type="checkbox"/>	Iw0001	1	HIGH		V	
05	Analog Output	-10.75 - +10.75V	<input type="checkbox"/>	0w0001	1	HIGH		V	

- Save the LIO definitions.

Click **Save** on the Toolbar. The Save Local I/O Message Box will be displayed. Click the **Yes (Y)** Button.

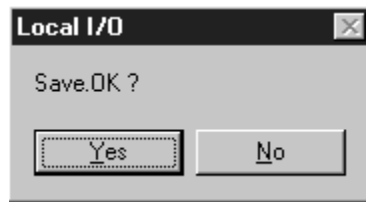

■ SVA Definitions

- Double-click **SVA** in slot 04.

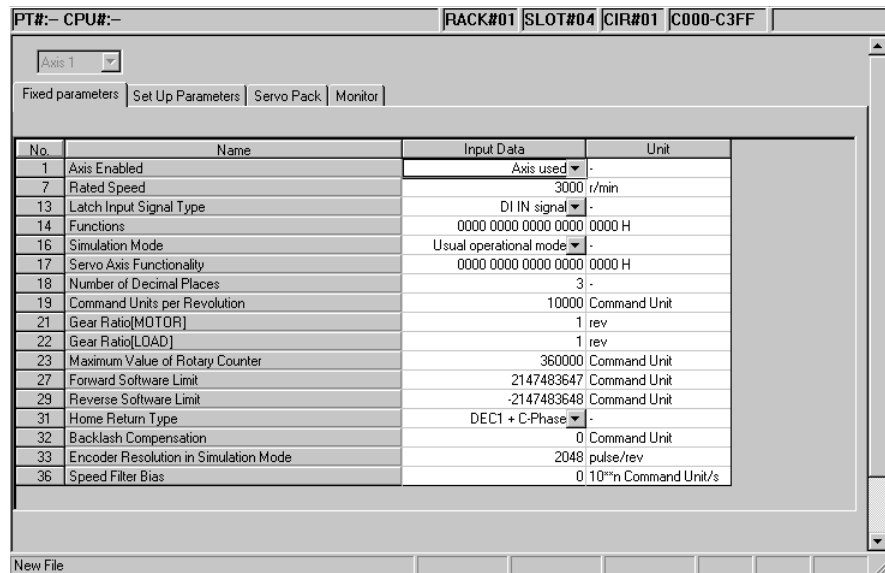

If no configurations have been saved, the New File Message Box will be displayed. Click the **OK** Button, and then perform the following operation.

2. Set SVA fixed parameter No. 1 (*Axis Enabled*) to *Axis Used*.

3. Save the fixed parameters.

Click **Save** on the toolbar. The Save SVA Definitions Message Box will be displayed.

Click the **Yes (Y)** Button.

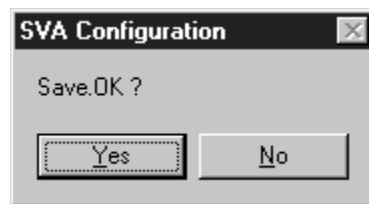

■ Default Settings for SGDH SERVOPACK Parameters

1. Click SERVOPACK in the SVA Definitions Window. The SERVOPACK Parameter Settings Window will be displayed.

Select **Edit (E)** and then **Default Set (R)** from the menus.

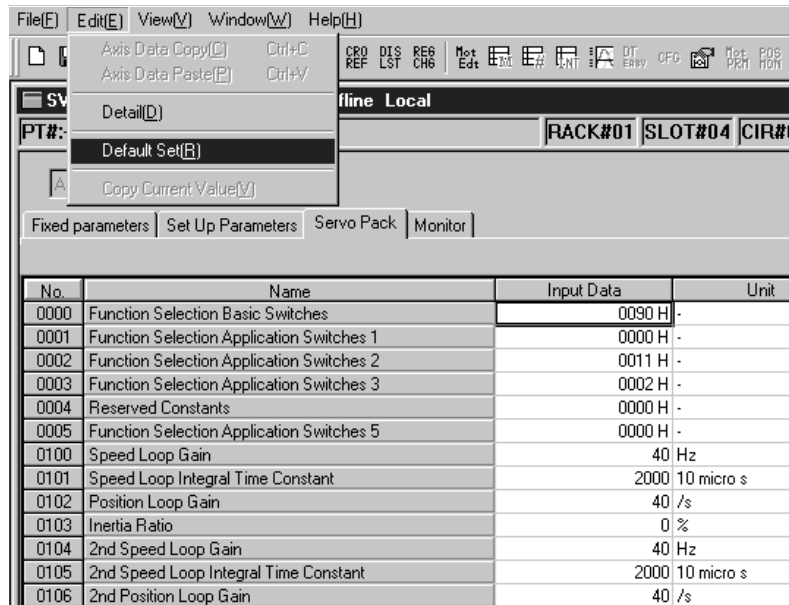

2. The SVA Definition Message Box will be displayed. Click the **Yes (Y)** Button to set the default values.

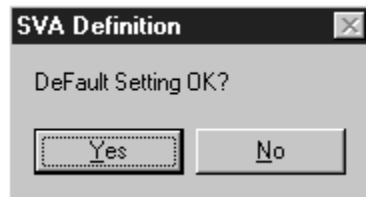

3. Save the SERVOPACK parameters.

Click **Save** on the toolbar. The Save SVA Configuration Message Box will be displayed. Click the **Yes (Y)** Button.

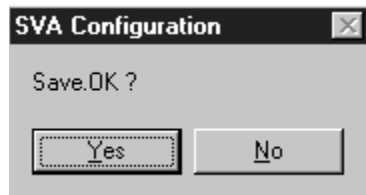

■ Defining the Counter Module

1. Double-click **CNTR** in slot 05. If no configurations have been saved, the New File Message Box will be displayed.

Click the **OK** Button, and then perform the following operation.

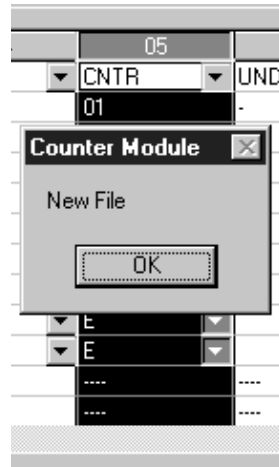

2. The Counter Module Window will be displayed. Set the synchronous scan on the Fixed Parameter Tab Page to **High**.

Make the settings according to the application program.

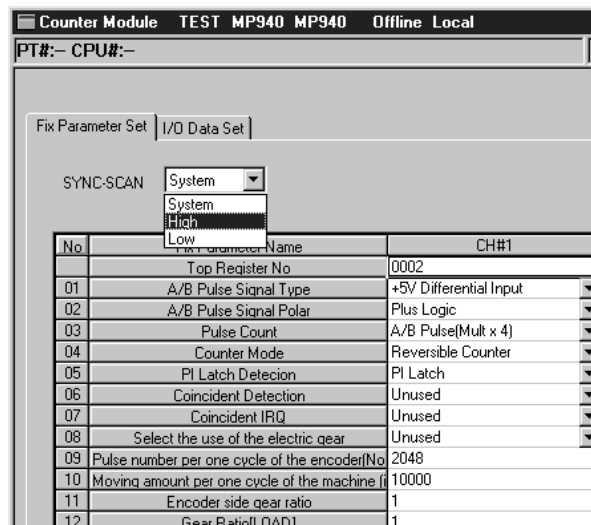

3. Click **Save** on the toolbar. The Counter Configuration Message Box will be displayed.

Click the **Yes (Y)** Button.

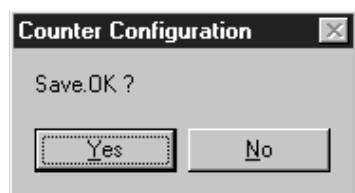

This completes setting the Module configurations. Next, turn OFF the power supply to the MP940 System, and then ON again.

- When you return to the Main Module Configurations Window, check that the status display for the function modules reads “Running.”

No.	00	01	02	03	04	05
Cir No	-	-	01	-	01	-
Module(Dual)						
Cir(Dual)						
Replacement						
I/O Start Register	----	----	----	0000	----	0002
I/O End Register	----	----	----	0001	----	0011
Input DISABLE				E		E
Output DISABLE				E		E
Motion Start Register	----	----	----	----	C000	----
Motion End Register	----	----	----	----	C3FF	----
Detail						
Status	Running		Running	Running	Running	Running

■ Setting the Scan Time

- Open the Controller Folder, Definitions Folder, and then double-click *Scan Time Setting*.

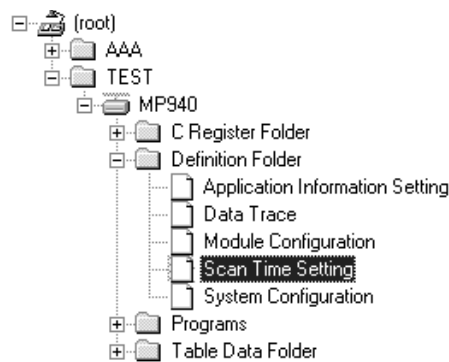

- In the Scan Time Window, set the *High-speed Scan Set Time* and *Low-speed Scan Set Time*. Next, select *Set (S)* and then *Basic Control Cycle (B)* from the menus.

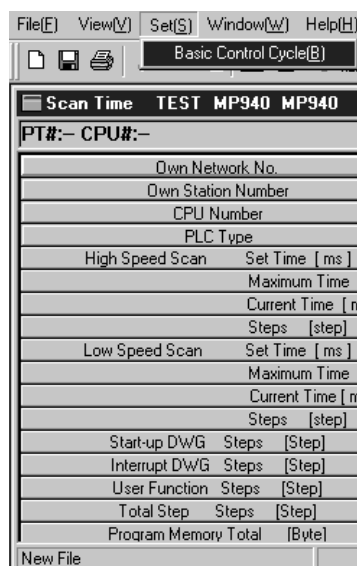

3. In the Basic Control Cycle Window, set the **Background Time** and **Watch Dog Set**. Change the Set Value. The Scan Time Message Box will be displayed. Click the **OK** Button.



4. Click **Save** on the toolbar. The Save Scan Time Message Box will be displayed. Click the **OK** Button.

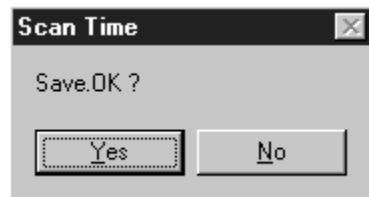

6 Parameters

This chapter describes the procedure for the setting parameters needed to run the MP940.

6.1 Parameter Classifications	6-2
6.2 Motion Setting Parameters	6-3
6.2.1 Opening the Motion Parameters Window	6-3
6.2.2 Setting Motion Parameters	6-4
6.2.3 Deleting Motion Parameters	6-7
6.2.4 Saving Motion Parameters	6-8
6.3 SVA Parameter Details	6-9
6.3.1 Motion Fixed Parameter Details	6-9
6.3.2 Motion Setting Parameter Details	6-17
6.3.3 Motion Monitoring Parameter Details	6-37
6.4 Parameters for SGDH SERVOPACK	6-46
6.4.1 Parameter Configurations	6-46
6.4.2 Function Selection Constants	6-46
6.4.3 Gain-related Parameters	6-53
6.4.4 Position-related Parameters	6-59
6.4.5 Speed-related Parameters	6-60
6.4.6 Torque-related Parameters	6-62
6.4.7 Sequence-related Parameters	6-66
6.4.8 Other Parameters	6-74

6.1 Parameter Classifications

This section describes parameters critical to motion functions in the Motion Module.

■ Overview

Parameters are specific constants needed for Motion Module motion functions. Set these parameters to values appropriate for machine specifications as well as for applicable Servo-drive (Servomotor + SERVOPACK) performance. Use a CP-717 Programming Device to create and edit parameters.

■ Parameter Tables

Parameters are classified into the following four types.

Classification	Register No.	Description
Fixed Parameters	No registers	These parameters set machine, Servomotor, encoder, and other mechanical conditions. They are not normally changed once they are set, and they cannot be changed while the system is running.
Setting Parameters	OWC000 to OWC03F	These parameters are used to provide commands to the servo control section. They can be set from a motion program or ladder logic program while the system is running.
Monitor Parameters	IWC000 to IWC03F	These parameters are servo monitor data reported by the servo control section. They can serve as reference for motion programs or ladder logic programs.
Servo Parameters	Pn000 to Pn601	These parameters are SERVOPACK parameters. They can be set from the Motion Parameters Window.

■ Editing Parameters

The following table describes the procedures used to create, edit, or change parameters.

Setting Method	Method	Settable Parameters
Personal Computer Programmer	Parameters are edited in the Definitions Folder from the Setting Window.	<ul style="list-style-type: none"> • Fixed parameters • Setting parameters • Servo parameters
Motion Programs	Motion programs can be used to set setting parameters (output registers OwC000 to OwC03F) with substitution statements.	<ul style="list-style-type: none"> • Setting parameters
Ladder Logic Programs	Parameters can be set directly from ladder logic programs.	<ul style="list-style-type: none"> • Setting parameters

6.2 Motion Setting Parameters

This section explains how to set MP940 motion parameters.

6.2.1 Opening the Motion Parameters Window

Double-click *SVA* in slot 04 in the Module Configuration Window.

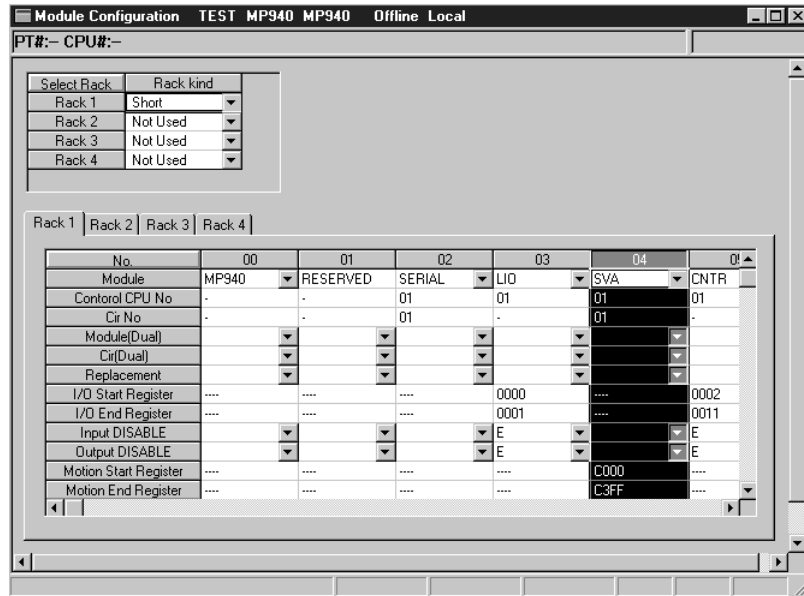

If you open the SVA Window before any settings have been made, the New Message Box will be displayed. Click the **OK** Button, and then perform the following operation.

6

The Motion Parameters Window will open.

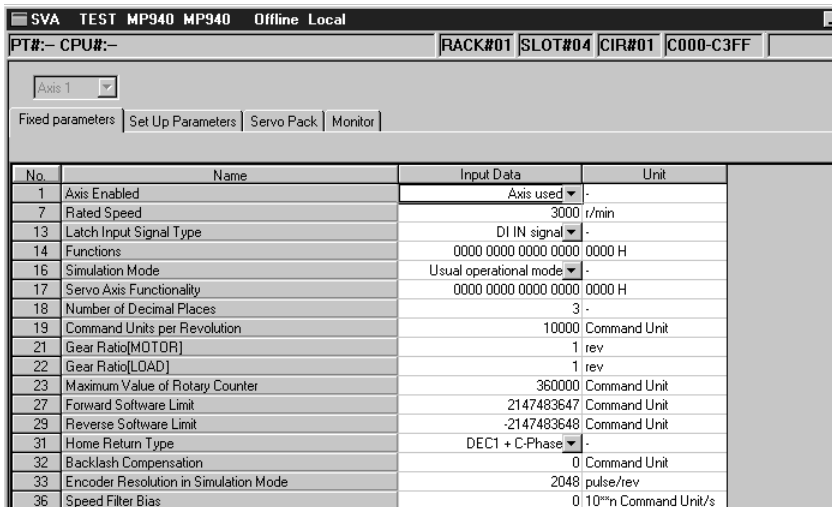

6.2.2 Setting Motion Parameters

■ Setting Fixed Parameters

In the Fixed Parameters Tab, set the fixed parameters necessary for servo adjustment.

No.	Name	Input Data	Unit
1	Axis Enabled	Axis used ▾	-
7	Rated Speed	3000	r/min
13	Latch Input Signal Type	DI IN signal ▾	-
14	Functions	0000 0000 0000 0000	0000 H
16	Simulation Mode	Usual operational mode ▾	-
17	Servo Axis Functionality	0000 0000 0000 0000	0000 H
18	Number of Decimal Places	3	-
19	Command Units per Revolution	10000	Command Unit
21	Gear Ratio[MOTOR]	1	rev
22	Gear Ratio[LOAD]	1	rev
23	Maximum Value of Rotary Counter	360000	Command Unit
27	Forward Software Limit	2147483647	Command Unit
29	Reverse Software Limit	-2147483648	Command Unit
31	Home Return Type	DEC1 + C-Phase ▾	-
32	Backlash Compensation	0	Command Unit
33	Encoder Resolution in Simulation Mode	2048	pulse/rev
36	Speed Filter Bias	0	10 ⁻ⁿ Command Unit/s

Item	Details
Axis number	The axis number is displayed in the combo box. The axis number is always Axis 1.
No.	The fixed parameter number.
Name	The name of the parameter being set.
Input Data	Enter (select) the parameter value. Refer to the motion fixed parameters tables.
Unit	The setting data unit.

Refer to 6.3.1 *Motion Fixed Parameter Details* for the details on fixed parameter settings.

Setting Default Setting Values

You can omit entering the fixed parameters, and set all parameters to their Default Setting values. The procedure for setting the Default Setting values is shown below.

1. Select **Edit (E)** and then **Default Setting (R)** from the motion parameter menus.
2. Click the **Yes (Y)** Button in the message box. The default values for the fixed parameters will be set.



If you do not save the fixed parameters, they will not be reflected in the Controller.

■ Setting Set Up Parameters

Click the Set Up Parameters Tab.

No.	Name	Reg.No.	Input Data	Unit	Cur
1	Run Mode	0wC000	0000 0000 0000 0000	0000 H	
2	Run Commands	0wC001	0100 0000 0000 0000	4000 H	
3	Forward Torque Limit	0wC002		300.00 %	
5	Forward Speed Limit	0wC004		150.00 %	
6	Reverse Speed Limit	0wC005		150.00 %	
7	Zero Point Offset	0LC006		0 Command Unit	
11	Home Approach Speed	0wC00A		0 10 ^m n Command Unit/s	
12	Home Creep Speed	0wC00B		0 10 ^m n Command Unit/s	
13	Linear Acceleration Time	0wC00C		0 ms	
14	Linear Deceleration Time	0wC00D		0 ms	
15	Positioning Completed Range	0wC00E		10 Command Unit	
16	Following Error Limit	0wC00F		0 pulse	
17	Position Loop Gain	0wC010		30.0 /s	
18	Feed-forward Gain	0wC011		0 %	
19	Position Reference Type	0LC012		0 Command Unit	
21	S-Curve Acceleration Time	0wC014		0 time	
22	Speed Reference	0wC015		0.00 %	

Item	Details
Axis number	The axis number is displayed in the combo box. The axis number is always Axis 1.
No.	The setting parameter number.
Name	The name of the parameter being set.
Reg-No.	The register number corresponding to the parameter name.
Input Data	Input (select) the parameter value. Refer to motion setting parameters tables for details.
Unit	The setting data unit.
Current Value	The parameter current values are displayed in online mode. In offline mode, nothing is displayed.

Refer to 6.3.2 *Motion Setting Parameter Details* for the details on the motion setting parameters settings.



- The set values will be saved to the machine control register when the Enter Key is pressed. Consequently, the current value display will be updated.
- The set values will be deleted when the power supply to the machine controller is turned OFF then ON again. Make sure to save the data so that it is available when the power supply is turned ON again.

Refer to 6.2.4 *Saving Motion Parameters* for details on the save operation.

Setting Default Values

You can omit entering the fixed parameters, and set all parameters to their default values. Refer to the default values in the setting parameters table for details. The procedure for setting the default values is shown below.

1. Select **Edit (E)** and then **Default Setting (R)** from the motion parameter menus.
2. Click the **Yes (Y)** Button in the message box. The default values for the setting parameters will be set.



- The default settings are enabled when they are saved to the machine controller registers. Consequently, the current value display will be updated.
 - The set value will be deleted when the power supply to the machine controller is turned OFF then ON again. Make sure to save the data so that it is available when the power supply is turned ON again.
- Refer to *6.2.4 Saving Motion Parameters* for details on the Save operation.

■ Setting SERVOPACK Parameters

Click the SERVOPACK Tag.

No.	Name	Input Data	Unit	Current Value
0000	Function Selection Basic Switches	0090 H -		
0001	Function Selection Application Switches 1	0000 H -		
0002	Function Selection Application Switches 2	0011 H -		
0003	Function Selection Application Switches 3	0002 H -		
0004	Reserved Constants	0000 H -		
0005	Function Selection Application Switches 5	0000 H -		
0100	Speed Loop Gain	40 Hz		
0101	Speed Loop Integral Time Constant	2000 10 micro s		
0102	Position Loop Gain	40 /s		
0103	Inertia Ratio	0 %		
0104	2nd Speed Loop Gain	40 Hz		
0105	2nd Speed Loop Integral Time Constant	2000 10 micro s		
0106	2nd Position Loop Gain	40 /s		
0107	Bias	0 r/min		
0108	Bias Width Addition	7 Command Unit		
0109	Feed-forward	0 %		
010A	Feed-forward Filter Time Constant	0 10 micro s		
010B	Gain-related Application Switches	0000 H -		

Item	Details
Axis number	The axis number is displayed in the combo box. The axis number is always Axis 1.
No.	The SERVOPACK parameter number.
Name	The name of the SERVOPACK parameter.
Input Data	Enter (select) the SERVOPACK parameter. Refer to <i>Appendix B Lists of Parameters</i> .
Unit	The setting data unit.
Current Value	The parameter current values are displayed in online mode. In offline mode, nothing is displayed.

Refer to *Chapter 6.4 Parameters for SGD H SERVOPACK* for details on SERVOPACK parameter settings.



- Set the SERVOPACK parameter default settings using the Edit (E) and Default Settings (R) command from the SERVOPACK Parameter Settings Window. The settings are enabled when they are saved. For details, refer to *Chapter 4.7.4 Setting Parameters of the SGD H SERVOPACK*.
- In the following cases, the SERVOPACK Parameter Window may read Time Over.
 - When a Digital Operator is connected to the SERVOPACK.
 - When using the serial command function (OWCC038).

■ Motion Monitor Display

Click the Monitor Tag. You cannot change the set values.

No.	Name	Reg-No.	Monitor Data	Unit
1	Drive Status	IWC000	-	-
2	Network Servo Status	IWC001	-	-
3	Target Position	ILC002	-	Cor
5	Incremental Target Position	ILC004	-	Cor
7	Machine Coordinate Latch Position	ILC006	-	Cor
9	Machine Coordinate Feedback Position	ILC008	-	Cor
11	Position Error	ILC00A	-	pul:
13	Speed Reference Output Value[%]	IWC00C	-	%
14	Speed Monitor	IWC00D	-	%
15	Torque Monitor	IWC00E	-	%
16	Over Range Parameter Number	IWC00F	-	-
17	Number of Absolute Encoder Turns	ILC010	-	rev
19	Initial Incremental Pulse of Absolute Encoder	ILC012	-	pul:
21	Servo Command Type Response	IWC014	-	-
22	Servo Module Command Status	IWC015	-	-
23	Number of Decimal Places	IWC016	-	-
24	Position Management Status	IWC017	-	-
25	Machine Coordinate System Position	IWC018	-	-

Item	Details
Axis number	The axis number is displayed in the combo box. The axis number is always Axis 1.
No.	The monitor parameter number.
Name	The monitor parameter name.
Reg-No.	The register number corresponding to the monitor parameter.
Monitor Data	The parameter current values are displayed in online mode. In offline mode, nothing is displayed.
Unit	The setting data unit.

Refer to 6.3.3 *Motion Monitoring Parameter Details* for details on the servo parameters used in motion monitoring.

6.2.3 Deleting Motion Parameters

1. Select **File (F)** and then **Delete (D)** from the motion parameters menus.
2. Click the **Yes (Y)** Button in the message box.

IMPORTANT

When you perform the delete operation, the fixed parameter and setting parameter data for all axes will be deleted.

6.2.4 Saving Motion Parameters

1. Select **File (F)** and then **Save (S)** from the motion parameters menus.
2. Click the **Yes (Y)** Button in the message box.
3. Click the **OK** Button in the message box.

IMPORTANT

- If the current value bit 1 (Servodrive operating) for Parameter No. 2 Servodrive Operation Reference is ON, you cannot save changes to the fixed parameters in the Setting Parameters Tab Page. First turn OFF bit 1, and then save the changes.
 - If the save operation fails, an error detection message box will be displayed. Clear the cause of the error, and then retry the save operation.
-

6.3 SVA Parameter Details

This section explains details on the MP940 parameters.

6.3.1 Motion Fixed Parameter Details

IMPORTANT

Motion fixed parameters cannot be changed if the current value of bit 0 is ON in motion setting parameter OWC001, RUN Command Settings. Positions and other data are initialized when a motion fixed parameter is changed.

Table 6.1 Motion Fixed Parameter Details



No.	Name	Description	Default
1	Axis Selection (USESEL)	Set whether an axis is used or not. 0: Not used. 1: Used. If an axis is set to be not used, then that axis will not be controlled and IWC000 to IWC03F monitor parameters will not be updated. Error information, however, will be stored in the operating status (IWC000) and alarm information will be stored in alarm (ILC022).	1
7	Rated Motor Speed Setting (NR)	Used in simulation monitor mode. Set motor speed at rated (100%) operation in 1 r/min units. Set this parameter based on the specifications of the Servomotor that is used.	3000
12	Not used.	---	
13	DI Latch Signal Selection (DIINTSEL)	Set the external signal that is used to latch DI. 0: Use the DI signal as a latch signal. 1: Use the C pulse as the latch signal. You can also use this parameter to select the latch signal during the EX_POSING (external positioning) and LATCH (interpolation with position detection function) motion commands.	0

No.	Name		Description		Default
14	Additional Function Selections (AFUNCSEL)		Set additional functions, such as the signal type used and signal functions.		
	Bit	0 to 1	Not used.	---	
		2	Limit Switch Signal Selection (LIMITSEL)	Set whether to use OBC001F or DI signal (DEC signal of SGD _H) as the limit switch signal when returning to the zero point. 0: Use OBC001F. 1: Use the DI signal (DEC signal of SGD _H). When using OBC001F, the external signal (DI signal input by the LIO_01 or other Module) in the user program must be connected (i.e., programmed) to OBC001F.	0
		3 to 6	Not used.	---	
		7	Motion Command Code Selection (MCMDSSEL)	Set whether or not to use an OWC020: Motion Command Code when bit 2 of OWC000: Position Control Mode is selected. 0: Not used. 1: Used.	1
	8 to 11	Not used.	---		
14	Bit	12 to 15	Deviation Error Abnormality Detection Value Coefficient (EOV_MULTI)	The deviation error is detected using the value of $\times 2^{EOV_MULTI}$ of the deviation error detection value setting (OWC00F). • Setting range: 0 to 15	0
15	Not used.		---		
16	Simulation Mode Selection (SIMULATE)		0 to 1	0: Normal operation mode 1: Simulation mode	0 (Normal operation)
17	Motion Controller Function Selection Flags (SVFUNCSEL)		Set whether a function is enabled or disabled when a motion command is used.		
	Bit	0 to 3	Reference Unit Selection (CMD_UNIT)	Set the reference unit that is input. 0: pulse (electronic gear disabled) 1: mm 2: deg 3: inch Set 0 to 3. When a unit is selected, the minimum unit that can be used as reference is determined by motion fixed parameter No. 18: Number of Digits Below the Decimal Point.	0 (pulse)

No.	Name		Description	Default
17	Bit	4	Electronic Gear Selection (USE_GEAR) Set whether or not to use the electronic gear function. 0: Disabled 1: Enabled The electronic gear is disabled even if this flag is enabled when pulse is selected as the reference unit.	0 (Disabled)
		5	Axis Selection (PMOD_SEL) Finite length/infinite length axis selection. Set whether or not there is a limit on controlled axis movement. 0: Finite length axis The axis will have limited movement. The software limit function is enabled. 1: Infinite length axis The axis will have unlimited movement. The software limit function is disabled.	0 (Finite length axis)
		6	Backlash Compensation Enabled Selection (USE_BKRSH) Set whether or not to enable backlash compensation. 0: Disabled 1: Enabled	0 (Disabled)
		7	Positive Software Limit Selection (USE_SLIMP) Set whether or not to use the software limit function in the positive direction when an OWC020: Motion Command Code is used (Set the override of interpolation system command to the register set by the group definition). 0: Disabled 1: Enabled Set the software limit at fixed parameter 27. • Software Limit Function Enable Timing • Valid after IBC0156: Zero Point Return Completed turns ON.	0 (Disabled)
		8	Negative Software Limit Selection (USE_SLIMN) Set whether or not to use the software limit function in the negative direction when an OWC020 Motion Command Code is used. 0: Disabled 1: Enabled Set the software limit at fixed parameter 29. • Software Limit Function Enable Timing • Valid after IBC0156: Zero Point Return Completed turns ON.	0 (Disabled)

6.3.1 Motion Fixed Parameter Details

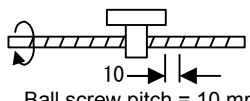
No.	Name		Description		Default
17	Bit	9	Override Selection (USE_OV)	Set whether or not to use the override function. 0: Disabled 1: Enabled The OWC02C: Override is used when this parameter is set to Enabled. The override is fixed at 100 if this parameter is disabled. Note: The override function allows the feed speed setting to be modified in an application.	0 (Disabled)
		10	Deceleration Limit Switch Inversion Selection (INV_DEC)	Set whether or not to invert and use the limit switch signal (speed limit switch) when returning to the zero point. 0: Do not invert 1: Invert	0 (Not inverted)
		11 to 12	Not used.	---	
		13	Positive Overtravel Selection (OVT1-SEL)	Set whether or not to use the overtravel function in the positive direction. 0: Disabled 1: Enabled	0 (Disabled)
		14	Negative Overtravel Selection (OVT2-SEL)	Set whether or not to use the overtravel function in the negative direction. 0: Disabled 1: Enabled	0 (Disabled)
		15	Not used.	---	0
18	Number of Digits Below Decimal Point (DECNUM)		Set the number of digits to the right of the decimal point in input reference units. The minimum reference unit is determined by this parameter and Reference Unit Selection in the Motion Controller Function Selection Flags (bit 0 to bit 3).		3

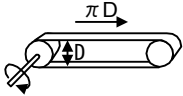
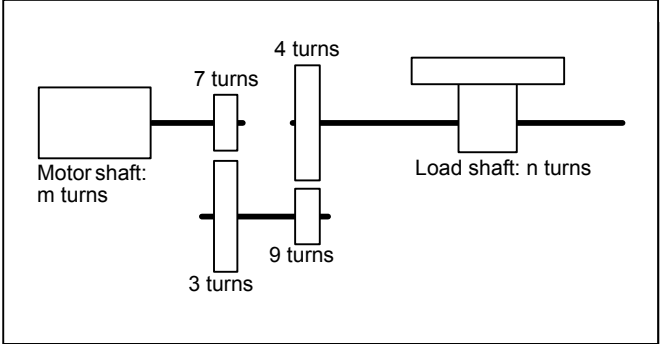
No.	Name	Description	Default	
19	Distance Traveled Per Machine Rotation (PITCH)	The minimum reference unit is determined by this parameter and Reference Unit Selection in the Motion Controller Function Selection Flags (bit 0 to bit 3). Setting range: 1 to $2^{31}-1$	10000	
		Ball screw  Ball screw pitch = 10 mm		Ball screw pitch = 10 mm Reference Unit Selection = mm Number of digits below decimal point = 3 ↓ Set the distance traveled per machine rotation to 10000.
		Rotating table  One rotation = 360°		One table rotation = 360° Reference Unit Selection = deg Number of digits below decimal point = 3 ↓ Set the distance traveled per machine rotation to 360000
		Belt 		One roller rotation = 360° Reference Unit Selection = mm Number of digits below decimal point = 3 ↓ Set the distance traveled per machine rotation to $\pi D \times 1000$.
21	Servomotor Gear Ratio (GEAR_MOTOR)	These parameters determine the gear ratio between the motor and the load. The following two values are set for a configuration in which the load shaft will turn n times in response to m turns of the motor shaft.	1	
22	Machine Gear Ratio (GEAR_MACHINE)	<ul style="list-style-type: none"> • Gear ratio at Servomotor: m • Gear ratio at load: n Setting Example  <p>In the above example, the reduction ratio is n/m, or $3/7 \times 4/9 = 4/21$. The following setting would thus be made. Servomotor Gear Ratio: 21 Load Gear Ratio: 4</p>	1	

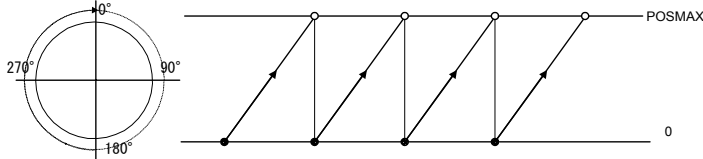
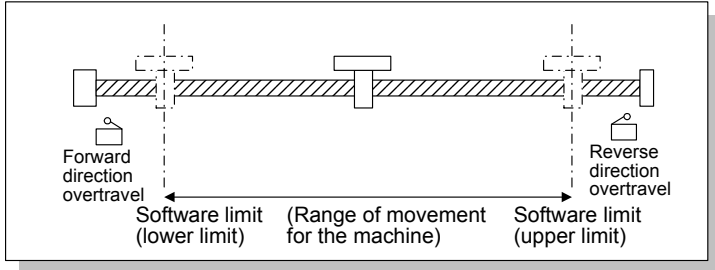
No.	Name	Description	Default
23	Infinite Length Axis Reset Position (POSMAX)	<p>Set the reset position for a rotation when infinite length axis is set. This parameter is not valid when a finite length axis is set.</p> <ul style="list-style-type: none"> Setting range: 1 to $2^{31}-1$ [reference units] <p>Example: The rotor will reset every 360°.</p> 	360000
27	Positive Software Limit (SLIMP)	<p>Set the positions at which the software limit function is to operate on the machine coordinate system.</p> <ul style="list-style-type: none"> Setting range: 1 to $2^{31}-1$ [reference units] <p>Whether or not the software limits are used is set in bit 7 and bit 8 of the Servo Controller Function Selection Flags at fixed parameter No. 17.</p>	$2^{31}-1$
29	Negative Software Limit (SLIMN)	<p>With the software limits, the upper and lower limits of the range of movement for the machine system are set at fixed parameters and the operating range is constantly monitored by the controller.</p> 	-2^{31}
31	Zero Point Return Method (ZRETSEL)	Set the zero point return method when returning to the zero point (ZRET) using OWC020: Motion Command Code. Refer to Zero Point Return Method on the next page for details.	0 (DEC1 + Phase-C pulse)
32	Backlash Compensation	Set the backlash compensation in reference units when the Backlash Compensation Selection (bit 6 of the Servo Controller Function Selection Flags at fixed parameter number 17) is set to enabled.	0
33	Number of Feedback Pulses per Motor Rotation (used in Simulation Mode)	<p>Use this parameter in simulation mode to set the feedback pulse (without multiplication) per motor rotation. Set the parameter according to the specifications of the encoder used.</p> <ul style="list-style-type: none"> Setting range: 4 to 2147483647 (P/R) <p>Always set a multiple of 4.</p>	2048
36	Bias Speed for the Exponential Acceleration/Deceleration Filter (EXPBIAS)	Set the bias speed for exponential acceleration/deceleration with bias.	0
37 to 48	Not used.	---	

The following sections describe the zero point return methods.

■ 0: DEC 1 + Phase-C pulse

This method has three speed levels.

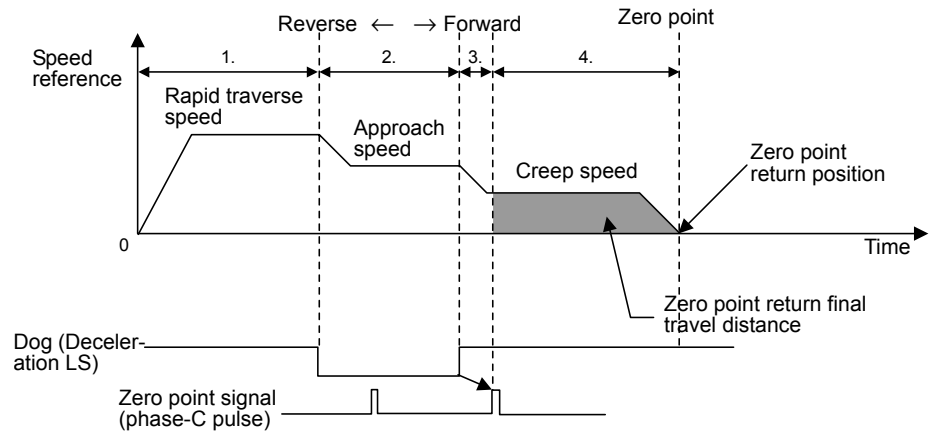

■ 6: DEC 2 + Phase-C pulse

This method searches for the zero point at creep speed after going in reverse at approach speed.

It is used for machine which requires excellent repeatability accuracy.

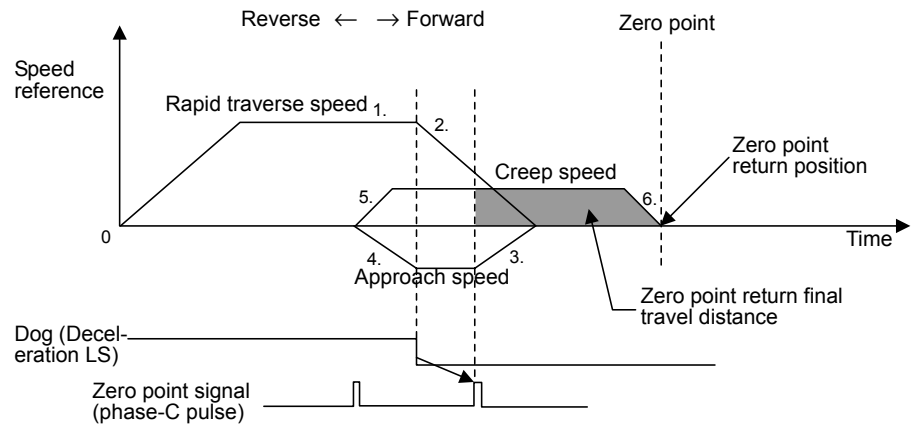

■ 7: DEC 1 + LMT + Phase-C pulse

This method gets the current position from the forward/reverse LMT signal and escapes automatically. It can return to the zero point from any position.

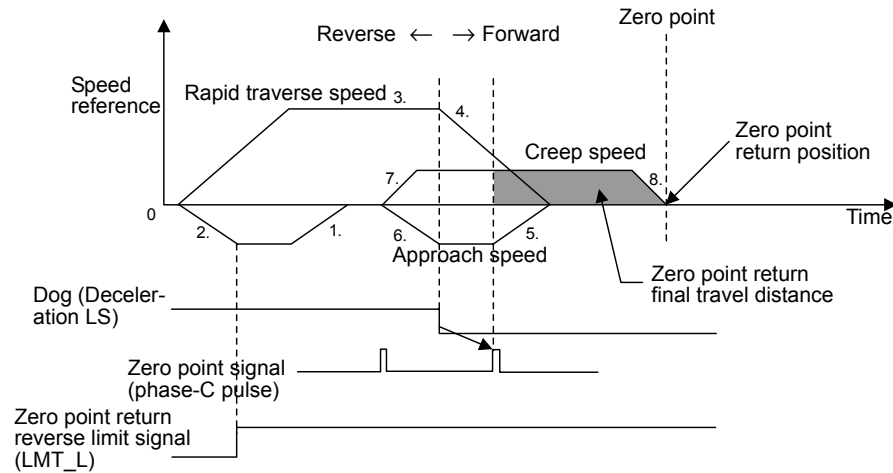

■ 3: Phase-C pulse

This method uses just the phase-C pulse of the servomotor to return to the zero point in machines that are not equipped with deceleration LS and other capabilities.

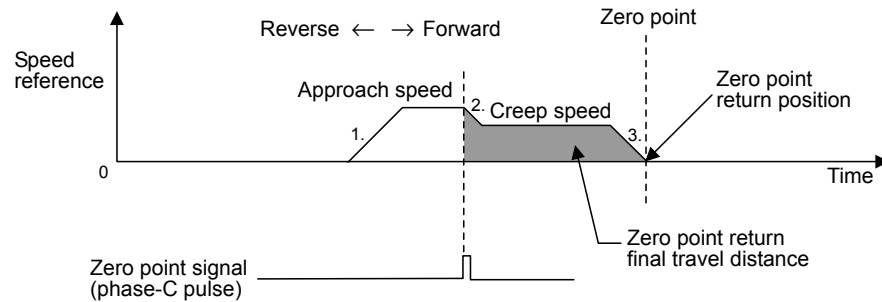

IMPORTANT

Connect the ZERO signal to EXT2 on the SERVOPACK.

■ 2: DEC 1 + Zero Signal

In place of the phase-C pulse of the DEC 1 + phase-C pulse method, this method uses the zero signal to return to the zero point.

■ 4: DEC 2 + Zero Signal

In place of the phase-C pulse of the DEC 2 + phase-C pulse method, this method uses the zero signal to return to the zero point.

■ 5: DEC 1 + LMT + Zero Signal

In place of the phase-C pulse of the DEC 1 + LMT + phase-C pulse method, this method uses the zero signal to return to the zero point.

■ 1: Zero Signal

In place of the phase-C pulse of the phase-C pulse method, this method uses the zero signal to return to the zero point.

6.3.2 Motion Setting Parameter Details

Caution

- Zero Point Position Offset in the Machine Coordinate System (ABSOFF)
This register contains data used by MP940 Modules for position control and the following movements are affected if this register is set incorrectly. Check to see if the data is set correctly prior to starting operation.
Obstructions may damage tools and lead to personal injury if this check is not performed.

Table 6.2 Motion Setting Parameter Details

No.	Name	Register Number	Bit Name	Description	Default	
1	RUN Mode Settings (RUNMOD)	OWC000		Set the RUN mode, such as Control Mode and Alarm Reset. The bit configuration is shown below.		
		Bit	0	Speed Reference Output Mode (NCON)	Used to set Speed Reference Output Mode.	0
			1	Torque Reference Output Mode (TCON)	Used to set Torque Reference Output Mode.	0
			2	Position Control Mode (PCON)	Used to set Position Control Mode.	1
			3	Phase Control Mode (PHCON)	Used to set Phase Control Mode	0
			4	Zero Point Return Mode (ZRN)	Used to set Zero Point Return Mode.	0
			5	Phase Control Test Mode (PHTEST)	Set whether the results of phase reference calculations and PI control calculations are valid or not in Phase Control Mode. 0: Not valid 1: Valid When Not Valid is selected, this parameter functions much like the Speed Reference Output Mode with the Filter Time Constant and Acceleration/Deceleration Time Constant set to 0.	0
			6	Alarm Clear (ACR)	The following monitor parameters will be cleared when this bit turns ON. • IWC000 RUN Status: Error Counter Over (bit 0) and Motion Setting Parameter Setting Error (bit 1) • Alarms (ILC022)	0

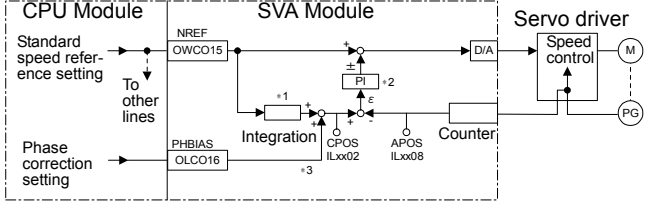
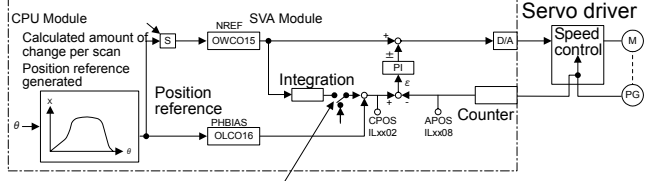
No.	Name	Register Number	Bit Name	Description	Default
1	RUN Mode Settings (RUNMOD), continued	Bit 7	Phase Reference Disable (PHREFOFF)	<p>Set whether to use phase control for the electronic shaft or electronic gear.</p> <p>0: Electronic shaft 1: Electronic gear</p> <ul style="list-style-type: none"> Phase Control Loop (Electronic Shaft)  <ol style="list-style-type: none"> Integrates the standard speed reference and calculates the corresponding position (pulse). Generates a speed reference from the difference between the target position (CPOS) and the current position (APOS). This is position (phase) correction. When shifting phase, the amount of shift (the rotating angle of the servomotor axis converted to pulses) is added as the phase correction setting. <ul style="list-style-type: none"> Electronic Cam Control Loop  <p>Phase reference generation calculation disabled The integration circuit is cut off when (bit 7 of OWC000) turns ON.</p> <p>The electronic cam control loop cuts off the integration circuit for the standard speed reference and provides a position reference based on the phase compensation setting.</p>	0
			Motion Command Mode Enable/Disable (MCDSEL)	<p>Set whether an OWC020: Motion Command Code is used or not.</p> <p>0: Not valid 1: Valid</p> <p>Valid when use (= 1) is set for the Motion Command Selection (bit 7 of fixed parameter number 14)</p>	1
			Zero Point Return Direction Selection (ZRNDIR)	<p>Set the direction for returning to the zero point.</p> <p>0: Reverse direction (position pulse in the deceleration direction) 1: Forward direction (position pulse in the acceleration direction)</p>	0
			Absolute Position Read Request (ABSRD)	<p>The absolute position data will be read from the absolute encoder when this bit turns ON. The IWC000: Absolute Position Read Completed Signal will turn ON when the data has been read. This parameter is used if the servo driver is turned OFF while the MP940 is ON.</p>	0

6.3.2 Motion Setting Parameter Details

No.	Name	Register Number	Bit Name	Description	Default	
1	RUN Mode Settings (RUNMOD), continued	Bit	11	Feed Forward Compensation during Control Mode Switching	When the feed forward value (OWC011) is set to other than 0, the speed reference value output is increased momentarily by the feed forward value when switching to control mode even when using the same speed command (e.g., speed to position). 0: Feed forward compensation OFF 1: Feed forward compensation ON	0
			12	Not used.	Set to "0."	0
			13	DI Latch Request (DIN-TREQ)	The current position the instant the DI latch signal turns ON is indicated in ILC006: Machine Coordinate System Latch Position when this bit is ON. Bit 11 of IWC000: DI Latch Completed Signal will turn ON when DI latch has been completed.	0
			14	Not used.	---	0
			15	Phase Control Integration Reset (IRESET)	The PI control integration is reset if this bit turns ON in Phase Control Mode.	0
2	RUN Command Settings (SVRUNCMD)	OWC001		Set the output signal from Motion Module to the SGDH SERVOPACK as well as the RUN mode required for motion control. The bit configuration is described below.		
		Bit	0	RUN Servo ON (DO0)	This parameter is used as the servo ON signal for the driver. "1" is output from DO0 if this bit is set to "1" when SVCRDY (IBC0007) is ON.	0
			1	P-CON	Speed loop P/PI switching	0
			2	G-SEL	Gain switching	0
			3	P-CL	Positive external torque control input	0
			4	N-CL	Negative external torque control input	0
			5	ZCLAMP	Zero clamp input	0
			6	PHSCANSEL	Phase control mode synchronous scan selection 0: H scan 1: S scan	0
			7	PSCANSEL	Position control mode Parameter synchronous scan selection 0: H scan 1: S scan	1
			8	ACCSEL	Position control mode Select whether to use acceleration and deceleration function 0: ON; 1: OFF	0
			9	SEGSEL	Position control mode Segment division 0: ON; 1: OFF	0
			10	Not used.	---	
11	Not used.	---				

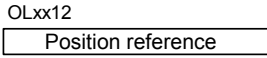
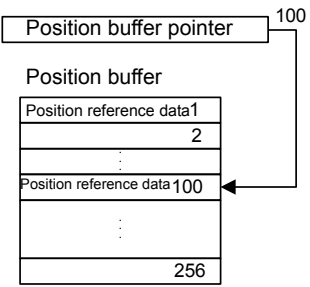
No.	Name	Register Number		Bit Name	Description	Default
2	RUN Command settings (SVRUNCMD), continued	Bit	12	Position Reference Value Selection (USE_BUF)	<p>Set the reference method that is used for position reference data. It is valid only when an OWC020: Motion Command Code is used in Position Control Mode.</p> <p>0: Use OLC012 as directly as position reference data.</p> <p>1: Use OLC012 indirectly as the position buffer number.</p> <p>Directly specified</p>  <p>Indirectly specified</p>  <ul style="list-style-type: none"> The position buffer is located in the MP940 Module and must be written in the initial drawing at startup. Refer to OBC021E, OBC021F, and OLC03A for details on writing to the position buffer. 	0
			13	Speed Reference Value Selection (SPD-TYPE)	<p>Set speed reference method for feed speed, approach speed, and creep speed. It is valid only when an OWC020: Motion Command Code is used in Position Control Mode.</p> <p>0: Set speed in reference units and sets rapid traverse speed at OLC022. The setting unit for OWC00A: Approach Speed and OWC00B: Creep Speed are also 1 = 10ⁿ reference units/min.</p> <p>1: Set speed using a percentage and sets rapid traverse speed at OLC015. The setting unit for OWC00A: Approach Speed and OWC00B: Creep Speed are also 1 = 0.01%.</p> <p>Refer to <i>11.3.1 Prerequisites for Position Control</i>.</p>	0

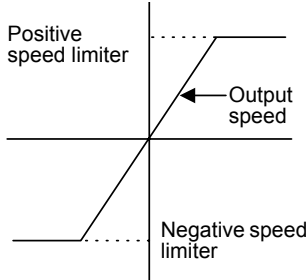
No.	Name	Register Number		Bit Name	Description	Default
2	RUN Command settings (SVRUNCMD), continued	Bit	14	Speed Reference Type (XREFTYPE)	Set the type of data for OLC012 Position Reference Setting when an OWC020: Motion Command Code is used in Position Control Mode. 0: Absolute position method Sets the absolute position at OLC012. 1: Add difference method Adds the current movement value to the previous value at OLC012 and then sets that data at OLC012. Note: This is an absolute position mode if the position reference selection is indirectly specified. Refer to 11.3.1 Prerequisites for Position Control. If using a motion program, be sure to set to 1: Add difference method.	1
			15	Zero Point Return Deceleration Point Limit Signal (LSDEC)	This signal functions as a limit switch signal (deceleration LS) when returning to the zero point. It is valid when bit 2: Limit Switch Signal Selection is OFF at fixed parameter number 14: Additional Function Selections. The external signal (DI signal input by the LIO-01 or other Module) in the user program must be connected (i.e., programmed) to OBC001F.	0
3	Positive Torque Limit Setting (TLIMP)	OWC002	-32768 to 32767	This parameter is used to set torque limit referenced by the SERVOPACK and inverter. • Unit: 0.01%	-300.00 (-300.00%)	
4	Not used.	OWC003		Set to "0."	0	
5	Positive Speed Limiter Setting (NLIMP)	OWC004	0 to 32767	Set the speed limiter value for the positive and negative directions as a percentage of the rated speed. The limiter speed will be output if the compensation speeds added to the specified speed exceeds this limiter value. 	150.00 (150.00%)	
6	Negative Speed Limiter Setting (NLIMN)	OWC005	0 to 32767		150.00 (150.00%)	

No.	Name	Register Number	Bit Name	Description	Default
7	Machine Coordinate System Zero Point Offset Setting (ABSOFF)	OLC006	-2^{31} to $2^{31}-1$	Position data can be shifted by the value set in this register. The parameter is valid during RUN operation, but set it while the system is OFF. This register contains data used by MP940 Modules for position control and the following movements are affected if this register is set incorrectly. Check to see if the data is set correctly prior to starting operation. Obstructions may damage tools and lead to personal injury if this check is not performed.	0
9	Not used.	OLC008		Set to "0."	0
11	Approach Speed Setting (Napr)	OWC00A	0 to 32767	Set the approach and creep speed when returning to the zero point (ZRET).	0
12	Creep Speed Setting (Nclp)	OWC00B	0 to 32767	The setting unit depends on OBC001D: Speed Reference Selection. 1. When OBC001D = 0 (specified in reference units) 1 = 10^n reference units/min (n = number of digits below the decimal point) Pulse unit: 1 = 1000 pulses/min mm unit: 1 = 1 mm/min deg unit: 1 = 1 deg/min Inch unit: 1 = 1 inch/min 2. When OBC001D = 1 (% specified), then 1 = 0.01% (percentage of the rated rotation speed). Note: A percentage is specified regardless of the setting at OBC01D in Zero Point Return Mode.	0

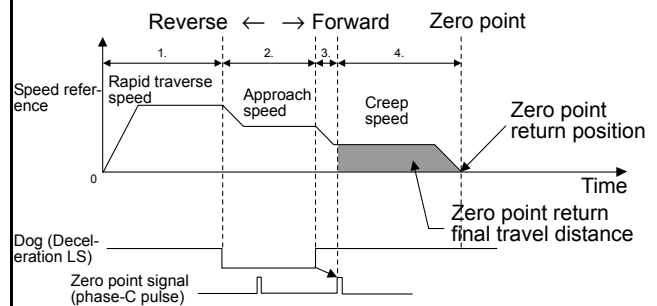

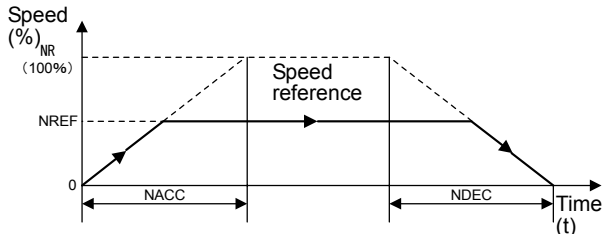
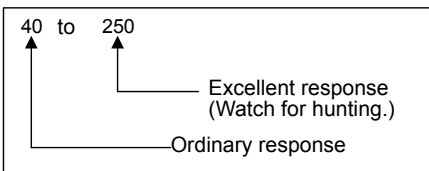
No.	Name	Register Number	Bit Name	Description	Default
13	Linear Acceleration Time Constant (NACC)	OWC00C	0 to 32767	Set the linear acceleration/deceleration time for Speed, Position Control, and Zero Point Return Modes.	0
14	Linear Deceleration Time Constant (NDEC)	OWC00D	0 to 32767	Unit: ms Set acceleration time from 0% to 100% (rated motor speed). 	0
15	Positioning Completed Range Setting (PEXT)	OWC00E	0 to 65535	This parameter is used in Position Control and Zero Point Return Modes. Set the range before bit 13 of IWC000: Positioning Completed Signal or bit 15 of IWC000: Zero Point Return Completed Signal turns ON. Unit: Reference unit Refer to the explanation on IWC000D.	10
16	Error Count Alarm Detection Setting (EOV)	OWC00F	0 to 65535	This parameter is used in Position, Phase Control, and Zero Point Return Modes. Set the limit for outputting bit 0 of IWC000: Error Counter Over. Outside this range, the Error Counter Over will turn ON and this value will be used as the error count in position control. Error Counter Over will not be detected if this parameter is set to "0." The deviation error is detected using the value of $\times 2^{EOV_MULTI}$ of the deviation error detection value setting (OWC00F) using the deviation error detection coefficient (EOV_MULTI) (Fixed parameter No. 14, bits 12 to 15).	65535
17	Position Loop Gain Setting (Kp)	OWC010	0 to 32767	Set the position loop gain in the servo system. Position loop gain is needed to set response performance for the servo system. The following are setting guidelines.  Set an appropriate value for the machine rigidity, inertia, and type of servomotor. <ul style="list-style-type: none"> Setting range: 1 to 32767 [0.1/S] 	300 (30.0)

No.	Name	Register Number	Bit Name	Description	Default
18	Feed Forward Gain Setting (Kf)	OWC011	0 to 200	<p>Reduces positioning time by applying feed forward control.</p> <ul style="list-style-type: none"> Setting range: 0 to 200 [%] <p>Reference position and actual position error decrease with higher settings.</p> <div style="border: 1px solid black; padding: 5px; margin: 10px auto; width: fit-content;"> <p>The machine may start to vibrate if the setting is too high.</p> </div>	0
19	Position Reference Setting (XREF)	OLC012	-2^{31} to $2^{31}-1$	<p>Set the position reference. The meaning of the setting data depends on OBC001C: Position Reference Selection and OBC001E: Position Reference Type.</p> <p>Explanation</p> <ol style="list-style-type: none"> Using OLC012 as Position Reference for Absolute Position Reference Method <ul style="list-style-type: none"> OBC001C = 0: Directly specified OBC001E = 0: Absolute position reference Using OLC012 as Position Reference for Add Difference Method <ul style="list-style-type: none"> OBC01C = 0: Directly specified OBC01E = 1: Add difference Using OLC012 as Position Reference for Add Difference Method <ul style="list-style-type: none"> OBC01C = 1: Indirectly specified OBC01E = 0: Absolute position reference <p>Note: Setting 1 causes setting parameter error. Refer to 11.3.1 Prerequisites for Position Control.</p>	0

No.	Name	Register Number	Bit Name	Description	Default
21	Filter Time Constant Setting (NNUM)	OWC014	<ol style="list-style-type: none"> Average move filter 0 to 255 (0 = 1 = no filter) Exponential acceleration/deceleration 0 to 32767 	<p>Set this parameter when performing simple S-curved acceleration/deceleration in speed reference output or position control mode.</p> <p>Speed Reference Output Mode Calculates the average move for the speed reference (Vr) and makes that value the speed reference.</p> <p>Position Control Mode Calculates the average move for the clear pulse (p) every scan and makes that value the position reference. Averaging will not be calculated in the following situations.</p> <ul style="list-style-type: none"> When switching during operation to Speed or Position Control Mode When the average number is changed during operation <p>OWC020: Motion Command Code Used in Position Control Mode The setting range for the filter time constant will vary with bit 4 to bit 7 of OWC021: Filter Type Selection.</p> <ul style="list-style-type: none"> Filter type 1 = Exponential filter 0 to 32767 Filter type 2 = Average move filter 0 to 255 <p>Note: This parameter will be valid when IBC0152: Distribution Completed turns ON if the filter time constant is changed.</p>	0
22	Speed Reference Setting (NREF)	OWC015	-32768 to 32767	<p>Speed Reference Output Mode Set the speed reference in 0.01% units.</p> <p>Position Control Mode Set the speed reference in a steady state in 0.01% units.</p> <p>OWC020: Motion Command Code Used in Position Control Mode Set the rapid traverse speed in 0.01% units (percentage of the rated motor speed) when the Speed Reference Selection (OBC001D) is set to 1.</p> <p>Phase Control Mode Set the standard speed reference in 0.01% units.</p>	0
23	Phase Bias Setting (PHBIAS)	OLC016	-2^{31} to $2^{31}-1$	Set the number of compensation pulses in Phase Control Mode. Use this parameter to compensate for reference pulses in control systems with no rigidity or gain.	0
25	Speed Compensation Setting (NCOM)	OWC018	-32768 to 32767	Set the speed compensation in 0.01% units in Phase Control Mode. OWC018: Speed Compensation Setting is valid even in Phase Control Mode if bit 10 of OWC021: Speed Compensation during Position Control is ON.	0
26	Proportional Gain Setting (PGAIN)	OWC019	0 to 32767	Set proportional gain for PI control in 0.1 units in Phase Control Mode.	300 (30.0)

No.	Name	Register Number	Bit Name	Description	Default
27	Integral Time Setting (Ti)	OWC01A	0 to 32767	Set the integral time for PI control in 1 ms units in Phase Control Mode. Integration will be reset if the integral time is set to 0.	300 (300ms)
28	Torque Reference Setting (TREF)	OWC01B	-32768 to 32767	Set the torque reference in 0.01% units in Torque Reference Output Mode.	0
29	Speed Limit Setting (NLIM)	OWC01C	-32768 to 32767	Set the speed limit in 0.01% units in Torque Reference Output Mode.	15000(150.00%)
31	Pulse Bias Setting (PULBIAS)	OLC01E	-2^{31} to $2^{31}-1$	This parameter is used in Position Control Mode. Position Control Mode Set the number of compensation pulses. OWC020: Motion Command Code Used in Position Control Mode This parameter is set in 1 pulse units when compensating reference pulses such as with backlash compensation. Compensation will not be performed however if IBC0170: Machine Lock is ON.	0
33	Motion Command Code (MCMDCODE)	OWC020	0 to 65535	Set the motion command code to the MP940 Module. This parameter can be used under the following conditions. <ul style="list-style-type: none"> • Motion Command Selection (bit 7 of fixed parameter no. 14) • Position Control Mode Selection (OBC0002) • RUN Mode Motion Setting Command Enabled (OBC0008) Motion Commands 0: NOP (no command) 1: Positioning (POSING) 2: External positioning (EX-POSING) 3: Zero point return (ZRET) 4: Interpolation (INTERPOLATE) 5: Do not use. Reserved for system use. 6: Interpolation with position detection (LATCH) 7: Feed (FEED) 8: Step (STEP) 9: Zero point setting (ZSET) 10 to 65535: Not used	0

No.	Name	Register Number	Bit Name	Description	Default
34	Motion Command Control Flags (MCMDCTRL)	OWC021		Set motion command auxiliary functions.	0
		Bit	0	Command Hold (HOLD) The machine decelerates to a stop if this bit turns ON while an axis is moving during positioning or step execution using an OWC020: Motion Command Code. IBC0151: Hold Completed turns ON when the HOLD has been completed. If this bit goes back OFF at this point, the hold is canceled and positioning restarts.	
			1	Command Abort (ABORT) The machine decelerates to a stop if this bit turns ON while an axis is moving during positioning, zero point return, or STEP using an OWC020: Motion Command Code. IBC0150: Busy turns ON if processing has been aborted. Step execution can be aborted by setting the motion command to NOP.	0
			2	Direction of Movement for JOG or STEP (DIRECTION) 0: Forward direction 1: Reverse direction	0 (Forward direction)
			3	No Primary Lag (LAGRST) The primary lag is reset if this bit turns ON in a position loop. It functions the same as when OWC037: Primary Lag Constant is set to "0" and it is used in Phase Control Mode or Zero Point Return Control Mode.	0
			4 to 7	Filter Type Selection (FILTERTYPE) 0: No filter 1: Exponential filter 2: Average movement filter OWC014: Filter Time Constant is valid if this parameter is set to "1" or "2."	0 (No filter)
			8	Position Loop P/PI Switch (POS_PPI) 0: P control 1: PI control This parameter is used in Phase Control Mode or Zero Point Return Mode.	0 (P control)
			9	Position Control Integration Reset (POS_IRST) PI control integration resets if this bit turns ON when using a position loop in PI control (Refer to bit 8 of OWC021.). The parameter is used in Phase Control Mode or Zero Point Return Mode. This parameter is used in Phase Control Mode or Zero Point Return Mode.	0
			10	Speed Compensation (OWC018) during Position Control (NCOMSEL) When this bit turns ON, data set at OWC018: Speed Compensation Setting is added as a speed compensation (1 = 0.01 %) to the position loop calculation. This parameter is used in Phase Control Mode or Zero Point Return Mode.	0
	11	SGDH Serial Command Enable (SCMD) SGDH Serial Command Enable Flag 0: ON; 1: OFF	0		

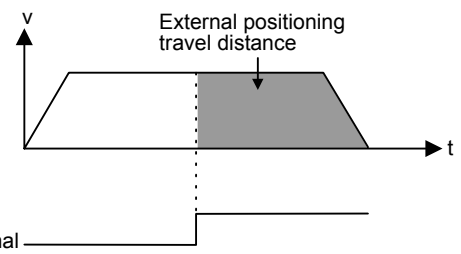
No.	Name	Register Number	Bit Name	Description	Default	
34	Motion Command Control Flag (MCMDCTRL), continued	Bit	12	Reverse Limit Signal for Zero Point Return (LMT_L)	This bit functions as a reverse limit signal when returning to the zero point (ZRET). The external signal in the user program must be connected (i.e., programmed) to OBC021C.	0
			13	Forward Limit Signal for Zero Point Return (LMT_R)	This bit functions as a forward limit signal when returning to the zero point (ZRET). The external signal in the user program must be connected (i.e., programmed) to OBC021D.	0
			14	Position Buffer Write (BUF_W)	Data set in OLC03A: Position Buffer Write Data is stored as absolute position data in the position buffer that is set at OLC038: Position Buffer Access Number.	0
			15	Position Buffer Read (BUF_R)	Data from the position buffer that is specified at OLC038: Position Buffer Access Number is stored as absolute position data in the position buffer that is set at ILC028: Position Buffer Read Data. This parameter is used to check position data that is stored in the position buffer. It takes two scans from the time the Position Buffer Read command is issued until the data is stored at ILC028: Position Buffer Read Data.	0
35	Rapid Traverse Speed (RV)	OLC022	0 to $2^{31}-1$	Set the rapid traverse speed in 10^n reference units/min (n: Number of digits below decimal point) if OBC001D: Speed Reference Selection is set to "0." Other setting units are expressed as follows: Pulse unit: 1 = 1000 pulses/min mm unit: 1 = 1 mm/min deg unit: 1 = 1 deg/min Inch unit: 1 = 1 inch/min This parameter is used when an OWC020: Motion Command Code is used in Position Control Mode.	3000	
37	External Positioning Travel Distance (EXMDIST)	OLC024	-2^{31} to $2^{31}-1$	Set the distance from the time the latch signal (external positioning signal) is input until the machine stops during external positioning (EX_POSING).  This parameter is used when an OWC020: Motion Command Code is used in Position Control Mode. Select either of the following latch signals using fixed parameter No. 13, DI Latch Signal Selection. Latch selection = DI input signal (EXT3) or C-pulse input signal.	0	

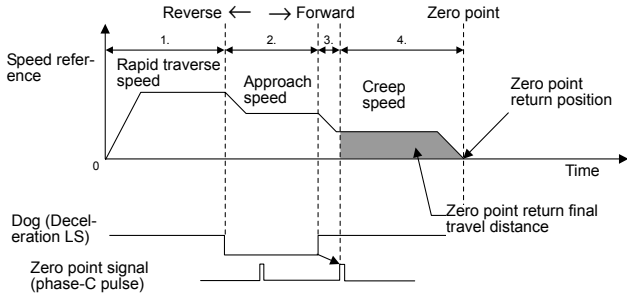
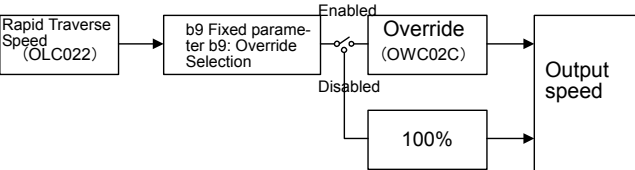
No.	Name	Register Number	Bit Name	Description	Default
39	Stopping Distance (STOPDIST)	OLC026	-2^{31} to $2^{31}-1$	This parameter is used by the system. Do not use it.	0
41	Step Travel Distance (STEP)	OLC028	0 to $2^{31}-1$	Set the travel distance in reference units for Step execution for the OWC020: Motion Command Code. • Unit: Reference unit	0
43	Zero Point Return Final Travel Distance (ZRNDIST)	OLC02A	-2^{31} to $2^{31}-1$	The machine is moved the distance set for this parameter after a valid zero point pulse is detected and then stops when returning to the zero point using an OWC020: Motion Command Code. The final point is set as the zero point of the coordinate system. • Unit: Reference unit 	0
45	Override (OV)	OWC02C	0 to 32767	Set the override for the output speed as a percentage of OWC015 or OLC022 (Rapid Traverse Speed) in 0.01% units. Rapid Traverse Speed Output Rapid Traverse Speed (OLC022) x Override (OWC02C) = Output speed  This parameter is valid when fixed parameter number 17: Override Selection (bit 9 of Motion Controller Function Selection Flags) is set to Enabled.	100,00

No.	Name	Register Number	Bit Name	Description	Default	
46	Position Control Flags (POSCTRL)	OWC02D		Set the functions related to position data managed by Motion Modules. The bit configuration is described below.		
		Bit	0	Machine Lock Mode Setting (MLK)	The axis does not actually move, but rather IWC002: Calculated Position in Machine Coordinate System is updated in Machine Lock Mode. This parameter is valid when IBC0152: Distribution Completed is ON if the parameter is changed and it is used when an OWC020: Motion Command Code is used in Position Control Mode.	0
			1	Request for the Preset Number of POSMAX Turns (TPRSREQ)	Request for the preset number of POSMAX turns. With an infinite length axis, a turn is counted every time the position value exceeds POSMAX and the count is stored at monitor parameter ILC01E: Number of POSMAX Turns. The number of turns can be preset at setting parameter OLC030: Preset Data for Number of POSMAX Turns by turning ON the Request for the Preset Number of POSMAX Turns Flag. Related Parameters <ul style="list-style-type: none"> • Fixed parameter 22: Maximum Value for Infinite Length Counter • Setting parameter OLC030: Preset Data for the Number of POSMAX Turns • Monitor parameter ILC01E: Number of POSMAX Turns 	0
			2	ABS System Infinite Length Position Control Data Load Request (ABSLDREQ)	If this bit is ON when using an infinite length axis with an absolute encoder, position data controlled by the SVA Module will be updated with data that is set at OLC038 and OLC03A: Encoder Position at Shutdown and at OLC03C and OLC03E: Pulse Position at Shutdown. This parameter is used when an OWC020: Motion Command Code is used in Position Control Mode. Conditions <p>Absolute encoder Fixed parameter no. 17 b5: 1, Infinite Length Axis</p>	0
			3	Position Monitor 2 (ILC034) Unit Selection	Set the data unit to be indicated at Position Monitor 2 (ILC034). <p>0: Reference unit Indicated as 1 = 1 reference unit.</p> <p>1: Pulse unit Indicated as 1 = 1 pulse unit.</p> This parameter is used when an OWC020: Motion Command Code is used in Position Control Mode.	0
			4 to 15	Not used.	Set to "0."	0
47	Workpiece Coordinate System Offset (OFFSET)	OLC02E	-2^{31} to $2^{31}-1$	Always set this parameter to "0." It is used by the system.	0	

6.3.2 Motion Setting Parameter Details

No.	Name	Register Number	Bit Name	Description	Default
49	Preset Number of POSMAX Turns Data (TURNPRS)	OLC030	-2^{31} to $2^{31}-1$	ILC01E: POSMAX Number of Turns can be preset with preset data by turning ON OBC02D1: Request for Preset Number of POSMAX Turns. It is used in situations such as when resetting the number of turns to "0." The parameter is used when an OWC020: Motion Command Code is used in Position Control Mode.	0
51	Second In-position Width (INPWIDTH)	OWC032	0 to 65535	Set the range where bit 2 of IWC017: Second In-position Completed will turn ON. Bit 2 of IWC017: Second In-position Completed will turn ON when IBC0152: Distribution Completed is ON and the difference between the command position and the feedback position is less than the value set here. This parameter is used when an OWC020: Motion Command Code is used in Position Control Mode.	0
52	Zero Point Position Output Width (PSETWIDTH)	OWC033	0 to 65535	Set the zero point position range. IBC0171: Zero Point Position will turn ON if $0 \leq \text{ILC018: Reference Position in Machine Coordinate System} \leq \text{Zero Point Position Output Width}$ when IBC0156: Zero Point Return Completed Status turns ON. The parameter is used when an OWC020: Motion Command Code is used in Position Control Mode.	10
53	Positioning Completed Check Time (PSETTIME)	OWC034	0 to 65535	Set limits for detecting bit 6 of ILC022: Positioning Time Over in $1 = 1$ ms. A positioning time over alarm will be generated if bit 13 of IWC000: Positioning Time Completed Signal does not turn ON when this range is exceeded after bit 2 of IWC015: Distribution Completed turns ON. The completion of positioning will not be checked if this parameter is set to "0." It is valid only when an OWC020: Motion Command Code is used in Position Control Mode.	0
54	Position Control Integral Time (PTI)	OWC035	0 to 32767	Set integral time in $1 = 1$ ms when using position loop and PI control (see bit 8 of OWC021). Integration will not be performed if this parameter is set to "0." The parameter is used in Position Control Mode or Zero Point Return Mode.	300
55	Upper/lower Limit for Position Control Integration (ILIMIT)	OWC036	0 to 32767	Set the upper and lower integration limits when using position loop and PI control (Refer to bit 8 of OWC021.) Integral output will be limited within the range set here when the integral output value exceeds this range.	32767
56	Primary Lag Time Constant (LAGTI)	OWC037	0 to 32767	Set the primary lag time constant in the position loop in $1 = 1$ ms. The primary lag will not be calculated if this parameter is set to "0." The parameter is used in Position Control Mode or Zero Point Return Mode.	0

No.	Name	Register Number	Bit Name	Description	Default
57	Encoder Position at Shutdown (Lower place)	OLC038	-2^{31} to $2^{31}-1$	<p>This parameter is used in the following two ways and should be used with care.</p> <ol style="list-style-type: none"> 1. Lower-place 2 Words of Encoder Position at Shutdown This parameter is valid when the motion fixed parameter: Encoder Selection is set to absolute encoder (= 1) and motion fixed parameter: Axis Selection (bit 5 of the Motion Controller Function Selection Flags) is set to an infinite length axis (= 1). When bit 2 of OWC02D: ABS System Infinite Length Position Control Data Load Request turns ON, the data set at this parameter will be treated as the lower-place two words of the encoder position at shutdown. 2. Position Buffer Access Number When bit 14 of OWC021: Position Buffer Write or bit 15 of OWC021: Position Buffer Read turns ON, the data set at this parameter will be treated as the buffer number of the position buffer. The setting range for this parameter is 1 to 256 and it is not valid if set to "0." It is used when an OWC020: Motion Command Code is used in Position Control Mode. 	0
	SGDH Serial Command Command Settings	OWC038	(Reserved for system use)	<p>Motion Command Control Flag SGDH parameters are read/written when (OBC021B)=1 1: Read data; 2: Write data</p> <p>Note: Can be used only when motion command code is enabled.</p> <p>SGDH serial command cannot be used with the following settings.</p> <ul style="list-style-type: none"> • The SERVOPACK Parameters Window is opened using CP-717 Programming Device. • A Digital Operator is connected to the SERVOPACK. 	0
	SGDH Serial Command Address Setting	OWC039	(Reserved for system use)	<p>Motion Command Control Flag Sets the SGDH parameter read/write address when the motion command control flag (OWC021B)=1.</p> <p>Note: Can be used only when motion command code is enabled.</p>	0

No.	Name	Register Number	Bit Name	Description	Default
59	Encoder Position at Shutdown (Upper place)	OLC03A	-2^{31} to $2^{31}-1$	<p>This parameter is used in the following two ways and should be used with care.</p> <ol style="list-style-type: none"> Upper-place 2 Words of Encoder Position at Shutdown This parameter is valid when the motion fixed parameter: Encoder Selection is set to absolute encoder (= 1) and motion fixed parameter: Axis Selection (bit 5 of the Motion Controller Function Selection Flags) is set to an infinite length axis (= 1). When bit 2 of OWC02D: ABS System Infinite Length Position Control Data Load Request turns ON, the data set at this parameter will be treated as the upper-place two words encoder position at shutdown. Position Buffer Write Data When bit 14 of OWC021: Position Buffer Write turns ON, the data set at this parameter will be written as absolute position data to the position buffer specified at OLC038. It is used when an OWC020: Motion Command Code is used in Position Control Mode. 	0
	SGDH Serial Command Data Setting	OWC03A	-32768 to 32767 (Reserved for system use)	<p>Motion Command Control Flag Sets the command data sent to the SGDH when SCMD (ObC021B)=1 and Data Write Command (OWC038)=2.</p>	0
61	Pulse Position at Shutdown (Lower-place)	OLC03C	-2^{31} to $2^{31}-1$	<p>When bit 2 of OWC02D: ABS System Infinite Length Position Control Data Load Request turns ON, the data set at this parameter will be treated as the lower-place two words of the pulse position at shutdown.</p> <p>This parameter is valid when the motion fixed parameter: Encoder Selection is set to absolute encoder (=1) and motion fixed parameter: Axis Selection (bit 5 of the Motion Controller Function Selection Flags) is set to an infinite length axis (=1). It is used when an OWC020: Motion Command Code is used in Position Control Mode.</p>	0
63	Pulse Position at Shutdown (Upper-place)	OLC03E	-2^{31} to $2^{31}-1$	<p>When bit 2 of OWC02D: ABS System Infinite Length Position Control Data Load Request turns ON, the data set at this parameter will be treated as the upper-place two words of the pulse position at shutdown.</p> <p>This parameter is valid when the motion fixed parameter: Encoder Selection is set to absolute encoder (= 1) and motion fixed parameter: Axis Selection (bit 5 of the Motion Controller Function Selection Flags) is set to an infinite length axis (= 1). It is used when an OWC020: Motion Command Code is used in Position Control Mode.</p>	0

■ Supplemental Explanation

1. The priority of the OWC000: RUN Mode Settings and the OWC001: RUN Command Settings is as follows:

The highest priority control mode will be executed if both turned ON at the same time.

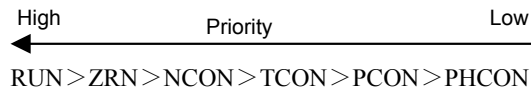

2. If bit 0 of OWC001: RUN Servo ON turns OFF during operation, operation will depend on the Control Mode.

- a) Position, Speed, Phase Control, or Zero Point Return Mode

The RUN signal will remain ON from the current speed reference until the machine decelerates to a stop in accordance with the OWC00D: Linear Deceleration Time Constant that was set.

- b) Torque Reference Output Mode

If the RUN signal turns OFF, 0 is output immediately as the speed reference, and the servo ON signal is turned OFF.

3. The latch selection signal will be either of the following depending on fixed parameter No. 13, DI Latch Detection Signal Selection.

- DI Latch Detection Signal Selection = 0: EXT3 (SGDH external input signal 3).
- DI Latch Detection Signal Selection = 1: Phase C (encoder phase C).

4. Procedure for Using the Zero Point Offset

- a) Applications where Absolute Encoder Rotates in One Direction

The zero point offset can be used in applications where the absolute encoder rotates in one direction by using OLC006: Machine Coordinate System Zero Point Offset Setting in the motion parameters and creating a user program that will control the absolute position.

- b) Initializing the Absolute Encoder

A pulse cannot be reset within one rotation simply by initializing the absolute encoder.

For example, an initial incremental pulse corresponding to 0.5 rotations will be sent even though the absolute encoder is reset if the servomotor stops at 95.5 rotations.

Consequently, position data corresponding to 0.5 rotations rather than 0 will be indicated at ILC008: Position Monitor.

Set the following in order to set the position monitor to 0.

Preconditions

Initialize the absolute encoder, restart the MP940, and then send a provisional 120 initial incremental pulses. A value of 120 will appear at the position monitor.

Procedure

The position can be adjusted with the Zero Point Offset. If the zero point offset is set to -120, the position monitor will show “0.”

The value set at the Zero Point Offset will be reset to “0” if the MP940 is turned OFF, so we recommend setting the parameter with Drawing A (initial processing drawing).

Example 1: Set DWG.A as follows:

└ OLC006 - 0000000120 ⇒ OLC006

Example 2: Set DWG.A as follows:

└ OLC006 - DL00022 ⇒ OLC006

Open the Register List Window and set DL00022 to 120 from the MP940 Programming Panel.

Because DL00022 (register D in DWG.A) is backed up by battery, this program will be executed and -120 will be set at OLC006 automatically when MP940 power is turned ON once the register is set.

DL00022 was used in this example, but any other D register (DLxxxxx) or M register (MLxxxxx) can be used as well.

Because the initial incremental pulse will change within a rotation every time the absolute encoder is initialized, the value -120 must be changed each time.

In Example 1, the user program must be changed from the Programming Panel.

In Example 2, only register data rather than the user program has to be changed and this is done from the Programming Panel.

Example 2 is the most practical method in applications like repeating machines.

5. If the fixed parameter for motion command code selection has been set to enable the use of motion command code and the motion command enable setting (OBC0008) has been set to 1 (enabled), set the number of reference units. Set the number of pulses at all other times.



Refer to 7.2.3 *Initializing the Absolute Encoder* for the procedure for initializing the absolute encoder.

6.3.3 Motion Monitoring Parameter Details

Table 6.3 Motion Monitor Parameter Details

No.	Name	Register No.	Bit Name	Description
1	RUN Status (RUNSTS)	IWC000		Indicate MP940 Module operating status. The bit configuration is described below.
		Bit	0	<p>Error Counter Over (EOVER)</p> <p>This bit turns ON when the ILC0j0A: Position Error exceeds the OWC00F: Error Counter Alarm Detection Setting.</p> <p>Note: Because control will not be interrupted, create a user program that will monitor this bit and perform other processing if application-specific processing, such as emergency stop, is required.</p> <p>The following items are potential causes for error alarms.</p> <ol style="list-style-type: none"> 1. OWC00F: Error Count Alarm Detection Setting is set too low. 2. The Servomotor is not operating. 3. Operation according to set references failed because the load in the machine system is too heavy. <p>This parameter is valid in Position Control Mode, Zero Point Return Mode, and Phase Control Mode.</p>
			1	<p>Motion Setting Parameter Setting Error (PRMERR)</p> <p>This bit turns ON when one or more of the motion setting parameters (OWC000 to OWC03F) is set outside the setting range. In this case, the most recent motion setting parameter number that caused the setting range alarm will be indicated at IWC00F: Parameter Number Out of Range.</p>
			2	<p>Motion Fixed Parameter Setting Error (FPRMERR)</p> <p>This bit turns ON when a motion fixed parameter is set outside the setting range. In this case, the most recent motion setting parameter number that caused the setting range alarm plus 100 will be indicated at IWC00F: Parameter Number Out of Range. This parameter will turn OFF automatically if an ordinary motion fixed parameter is set from the CP-717.</p>
			3	<p>Not used.</p> <p>---</p>
			4	<p>Commulative Number of Rotations Received Error (PGER)</p> <p>The absolute position is sent and received over serial lines when the power supply is turned ON and bit 10 of OW0000: Absolute Position Read Request turns ON when an absolute encoder is used. This Parameter turns ON if a receive error occurs.</p>
			5	<p>Not used</p> <p>---</p>
			6	<p>Not used</p> <p>---</p>
			7	<p>Motion Controller RUN Ready (SVCRDY)</p> <p>This parameter turns ON when RUN preparations for the Motion Module have been completed. The following may be reason why RUN preparations are not completed.</p> <ol style="list-style-type: none"> 1. Major damage has occurred. 2. Axis that is not used was selected (motion fixed parameter setting). 3. Motion fixed parameter setting error. 4. Cumulative no. of rotations received error. 5. Motion fixed parameters are being changed. 6. Absolute position is being read from the absolute encoder.

6.3.3 Motion Monitoring Parameter Details

No.	Name	Register No.	Bit Name	Description	
1	RUN status (RUNSTS), continued	Bit	8	Motion Controller RUN (SVCRUN)	<p>This bit turns ON under the following conditions.</p> <ul style="list-style-type: none"> • IBC007: RUN Ready turns ON. • OBC0000 to OBC0004: One of the Control Mode Flags turns ON. • OBC0010: Servo ON turns ON. <p>If an alarm is generated even though this bit is ON in Position Control Mode when an OWC020: Motion Command Code is used, the axis will not move even if a motion command is issued.</p> <p>Clear the alarm, set the motion command to “NOP” for 1 scan or more, and then set the motion command again.</p>
			9	Rotation Direction when Using Absolute Encoder (DIRINV)	<p>Rotation direction when using an absolute encoder</p> <p>Monitors the rotation direction selected for motion fixed parameters.</p> <p>0: Forward 1: Reverse</p>
			10	Absolute Position Read Completed Signal (ABSRDC)	<p>This parameter turns ON when bit 10 of OWC000: Absolute Position Read Request turns ON and absolute position data from the absolute encoder is read. If an error occurs, bit 4 of IWC000: Cumulative Number of Rotations Received error will turn ON.</p>
			11	DI Latch Completed Signal (DIINT)	<p>This parameter turns ON when bit 13 of OWC000: DI Latch Request turns ON and the DI latch signal is input. The current position at this time will be indicated at ILC006: Latch Position in Coordinate System.</p>
			12	Feedback Pulse 0 (FBP0)	<p>This parameter indicates that there is no feedback pulse and is normally ON if the servomotor is not operating.</p> <p>If this bit remains ON even though a reference is output, the feedback signal line from PG is very likely broken.</p>
			13	Positioning Completed Signal (POSCOMP)	<p>This parameter turns ON when positioning is completed in Position Control Mode.</p> <ol style="list-style-type: none"> 1. Motion Commands Not Used This parameter turns ON when $ILC008: \text{Current Position} - OLC012: \text{Position Reference} \leq OWC00E: \text{Positioning Completed Range}$ 2. Motion Command Used This parameter turns ON when bit 2 of IWC015: Distribution Completed turns ON and when $ILC008: \text{Current Position} - OLC018: \text{Reference Position in Machine System} \leq OWC00E: \text{Positioning Completed Range}$.
			14	Not used.	---
			15	Zero Point Return Completed Signal (ZRNC)	<p>This parameter turns ON when a return to zero point is completed in Zero Point Return Mode. It turns ON when $ILC008: \text{Current Position} - \text{Zero Point Position} \leq OWC00E: \text{Positioning Completed range}$.</p>
2	Servodrive Status (SYSTS)	IWC001		Reports the SERVOPACK status information. This status information is not used to control the Motion Module. Use to control the user program as necessary. The bit configurations are shown below.	
		Bit	0	ALM	Servo alarm
			1	WARN	Warning

No.	Name	Register No.	Bit Name	Description	
2	Servodrive Status (SYSTS), continued	Bit	2	V-CMP	Speed coincidence
			3	TGON	Detection during monitor rotation
			4	S-RDY	Servo ready
			5	CLT	Torque control detection
			6	VLT	Speed control detection
			7	BK	Brake interlock
			8	SVON	Servo ON completed
			9	PON	Main circuit power ON
			10 to 15		Not used.
3	Calculated Position in Machine Coordinate System (CPOS)	ILC002	-2^{31} to $2^{31}-1$	This parameter indicates the calculated position in a machine coordinate system controlled by MP940 Modules. Normally the position data indicated at this register is the target position for each scan. Refer to Supplemental Explanation.	
5	Target Position Difference Monitor (PTGDIF)	ILC004	-2^{31} to $2^{31}-1$	This parameter indicates the amount cleared every scan.	
7	Machine Coordinate System Latch Position (LPOS)	ILC006	-2^{31} to $2^{31}-1$	This parameter indicates the current position the instant the DI latch signal turned ON. Refer to Supplemental Explanation.	
9	Machine Coordinate System Feedback Position	ILC008	-2^{31} to $2^{31}-1$	This parameter indicates the current monitor position. Note: It is not valid when an A Drawing is executed. It is valid when an H or L Drawing is executed. Refer to Supplemental Explanation.	
11	Position Error (PERR)	ILC00A	-2^{31} to $2^{31}-1$	This parameter indicates the position error (number of pulses held). (Position error = target position - current position for each scan). It is valid in Zero Point Return Mode, Position Control Mode, and Phase Control Mode.	
13	Speed Reference Output Monitor (SPDREF)	IWC00C	-32768 to 32767	This parameter indicates the value output at the servo drive as the speed reference output value.	
14	Speed Monitor (NFB)	IWC00D	-32768 to 32767	Reports SGDh parameter Un000: Actual Motor Rotation Speed (r/min.) as %/number of rated rotations. 1=1%	
15	Torque Monitor (TFB)	IWC00E	-32768 to 32767	Reports the value of SGDh parameter: Un002 Internal Torque Reference (%). 1=0.01%	
16	Out of Range Parameter Number (ERNO)	IWC00F	1. Motion setting parameter 1 to 65 2. Motion fixed parameter 101 to 148	This parameter indicates the most recent setting parameter number that exceeded the range in OWC000 to OWC03F motion setting parameter or motion fixed parameter settings. • Motion setting parameters: 1 to 65 • Motion fixed parameters: 101 to 148 When motion fixed parameters are used, the parameter indicates the parameter number plus 100.	

6.3.3 Motion Monitoring Parameter Details

No.	Name	Register No.	Bit Name	Description	
17	Cumulative Rotations from Absolute Encoder (ABSREV)	ILC010	-2^{31} to $2^{31}-1$	This parameter indicates the cumulative number of rotations received from the absolute encoder. It is valid only when using an absolute encoder.	
19	Initial Incremental Pulses from Absolute Encoder (IPULSE)	ILC012	-2^{31} to $2^{31}-1$	This parameter indicates the initial number of incremental pulses received from the absolute encoder. It is valid only when using an absolute encoder.	
21	Motion Command Response Code (MCMDCODE)	IWC014	0 to 65535	This parameter indicates the OWC020: Motion Command Code that is currently executing. Refer to OWC020 for details on motion commands. The parameter is valid in Position Control Mode when an OWC020: Motion Command Code is used.	
22	Motion Command Status (MCMDSTS)	IWC015	These parameters indicate the executing status of an OWC020: Motion Command Code. They are valid in Position Control Mode when an OWC020: Motion Command Code is used. The bit configuration is described below.		
		Bit	0	Command Executing Flag (BUSY)	This parameter indicates the motion command status. 0: READY (completed) 1: BUSY (processing) This bit is used for abort status.
			1	Command Hold Completed Flag (HOLDL)	This parameter turns ON when a HOLD is completed. Refer to individual motion functions for details on the HOLD function.
			2	Distribution Completed (DEN)	This parameter turns ON when the amount of movement cleared is completed.
			3	Zero Point Setting Completed (ZSET)	This parameter turns ON when the zero point setting (ZSET) has been executed by OWC020: Motion Command Code. It also turns ON when b3 of IWC017: ABS System Infinite Length Position Control Data Load Request has finished execution.
			4	External Positioning Signal Latched (EX_LATCH)	This parameter turns ON when the external positioning signal is input during external positioning (EX_POSING).
			5	Command Error End (FAIL)	This parameter turns ON if an alarm occurs while a move (positioning, feed, etc.) command is being executed. Operation cannot continue once this bit turns ON. Set the motion command to "NOP."
			6	Zero Point Return Completed (ZRNC)	This parameter turns ON when zero point return or zero point setting has been completed. It turns OFF when zero point return begins.
			7 to 15	Not used.	---
23	Number of Digits Below Decimal Monitor (DECNUMM)	IWC016	0 to 5	This parameter indicates motion fixed parameter number 18: Number of Digits Below Decimal Point and is valid in Position Control Mode when an OWC020: Motion Command Code is used.	
24	Position Control Status (POSSTS)	IWC017	This parameter indicates status related to position controlled by MP940 Modules. It is valid in Position Control Mode when an OWC020: Motion Command Code is used. The following shows the bit configuration.		
		Bit	0	Machine Lock ON (MLKL)	This parameter turns ON when machine lock is ON. Outputs will not be made to the SGDH when this bit is ON. The axis that is being controlled will be locked and will remain stopped.

No.	Name	Register No.	Bit Name	Description	
24	Position Control Status (POSSTS), continued	Bit	1	Zero Point Position (ZERO)	This parameter turns ON when zero point return (IBC0156) has been completed and when $0 \leq \text{ILC018: Reference Position in Machine Coordinate System} \leq \text{OWC033: Zero Point Position Output Width}$.
			2	Second In-position Completed (PSET2)	This parameter turns ON when Distribution Completed (IWC015 bit 2) is ON and when $ \text{ILC008: Current Position} - \text{ILC018: Reference Position in the Coordinate System} \leq \text{OWC032: Second In-position Width}$.
			3	ABS System Infinite Length Position Control Data Load Completed (ABSLDE)	This parameter turns ON when OBC02D2: ABS System Infinite Length Position Control Data Load Request turns ON and the load has been completed. It turns OFF when OBC02D2: ABS System Infinite Length Position Control Data Load Request turns OFF and is valid when infinite length axis is set with an absolute encoder.
			4	Preset Request for Number of POSMAX Turns Completed (TPRSE)	This parameter turns ON when OBC02D1: Request for Preset Number of POSMAX Turns is ON and presetting has been completed. It turns OFF when OBC02D1: Request for Preset Number of POSMAX Turns goes OFF and is valid when infinite length axis is set.
			5	Electronic Gear Enabled Selection (GEARM)	This parameter indicates the electronic gear enabled selection at bit 4 of motion fixed parameter number 17.
			6	Axis Selection (MODSELM)	This parameter indicates the axis selection at bit 5 of motion fixed parameter number 17.
			7 to 15	Not used.	---
25	Machine Coordinate System Reference Position (MPOS)	ILC018	-2^{31} to $2^{31}-1$	This parameter is the reference position in the machine coordinate system and is basically the same value at ILC002 (CPOS). This position data cannot be updated if IBC0170: Machine Locked is ON. It is valid in Position Control Mode when an OWC020: Motion Command Code is used.	
27	Serial Command Answer Monitor	ILC01A	(Reserved for system use)	Answer monitor during SGDH serial command execution 1. Reading data 01H: Normal 41H: Data error 81H: Address error 2. Writing data 02H: Normal 42H: Data error 82H: Address error C2H: Answer timed out	
28	Serial Command Data Monitor	IWC01B	(Reserved for system use)	Data monitor during SGDH serial command execution	
29	POSMAX Monitor (PMAXMON)	ILC01C	1 to $2^{31}-1$	This parameter indicates the infinite length axis reset position (POSMAX) at motion fixed parameter number 23. It is valid in Position Control Mode when an OWC020: Motion Command Code is used.	

6.3.3 Motion Monitoring Parameter Details

No.	Name	Register No.	Bit Name	Description	
31	Number of POSMAX Turns (PMAXTURN)	ILC01E	-2^{31} to $2^{31}-1$	The count at this parameter goes up and down every time the reset position (POSMAX) for the infinite length axis at motion fixed parameter 23 is exceeded. The parameter can be preset with OLC030: Preset Number of POSMAX Turns and with OBC02D1: Request for Preset Number of POSMAX Turns and is valid in Position Control Mode when an OWC020: Motion Command Code is used.	
33	Serial Command Data Monitor	ILC020	(Reserved for system use)	Data monitor during SGDH serial command execution	
35	Alarms (ALARM)	ILC022		The following bits are valid in Position Control Mode when an OWC020: Motion Command Code is used. Alarm data and a halt to operation are indicated if this register shows anything other than "0." The register can be cleared by starting up OBC0006: Alarm Clear. The following shows the bit configuration.	
		Bit	0	Servo Amp Error	This bit turns ON when the Servo Alarm (IBC0010) is ON, or when there is a synchronous access error between the MP940 and SGDH.
			1	Positive Overtravel	This parameter turns ON when the positive overtravel signal is input and a move command is executed in the positive direction. It is valid if Enabled is selected at bit 13 of Motion Controller Function Selection Flags: Positive Overtravel Selection is enabled in motion fixed parameter 17.
			2	Negative Overtravel	This parameter turns ON when the negative overtravel signal is input and a move command is executed in the negative direction. It is valid if bit 14 of Motion Controller Function Selection Flags: Negative Overtravel Selection is enabled in motion fixed parameter 17.
			3	Positive Software Limit (SOTF)	This parameter is valid if IBC0156: Zero Point Return Completed turns ON when the positive software limit is enabled and an infinite length axis is selected. 1. OWC020: Motion Command Code Interpolation This bit turns ON when ILC018: Reference Position in Machine Coordinate System + OLC026: Stopping Distance \geq Positive Software Limit (motion fixed parameter no. 27). 2. OWC020: Motion Command Codes Positioning, Feed, or Step This bit turns ON when ILC018: Reference Position in Machine Coordinate System \geq Negative Software Limit (motion fixed parameter no. 27).

No.	Name	Register No.	Bit Name	Description	
35	Alarms (ALARM), continued	Bit	4	Negative Software Limit (SOTR)	This parameter is valid if IBC0156: Zero Point Return Completed turns ON when the negative software limit is enabled and an infinite length axis is selected. 1. This bit turns ON when ILC018: Reference Position in Machine Coordinate System + OLC026: Stopping Distance \leq Negative Software Limit (motion fixed parameter no. 29). 2. OWC020: Motion Command Codes Positioning, Feed, or Step This bit turns ON when ILC018: Reference Position in Machine Coordinate System \leq Negative Software Limit (motion fixed parameter no. 29).
			5	Not used.	---
			6	TIMEOVER	This bit turns ON if bit 13 of IWC000: Positioning Completed Signal does not turn ON when the Positioning Completed Check Time (OWC034) is exceeded after bit 2 of IWC015: Distribution Completed is turned ON.
			7	Over speed	This bit turns ON when the electronic gear's limit is exceeded.
			8 to 9	Not used.	---
			10	Control Mode Error (MODERR)	This parameter turns ON when a move command is set at OWC020: Motion Command Code in a mode other than Position Control Mode (OBC0002 is OFF).
			11	Zero Point Not Set (ZSET_NRDT)	This parameter turns ON when an attempt is made to execute one of the following motion commands with the bit 3 of IWC015: Zero Point Setting Completed Signal turned OFF. • POSING • EX-POSING • INTERPOLATE • ENDOF-INTERPOLATE • LATCH The parameter is valid if infinite length axis is set when an absolute encoder is used.
			12 to 13	Not used.	---
			14	Servodrive Synchronous Communications Error	An error has occurred in the synchronous access between the MP940 and SGDH.
			15 to 16	Not used.	---
			17	ABS Encoder Count Exceeded	This parameter turns ON when the absolute encoder count exceeds the range that the Motion Module can handle. The parameter is valid if infinite length axis is set when an absolute encoder is used.
18 to 31	Not used.	---			
37	Servo Drive Alarm Code (SVALARM)	IWC024	-32768 to 32767	Reports the SERVOPACK alarm code currently being generated.	

6.3.3 Motion Monitoring Parameter Details

No.	Name	Register No.	Bit Name	Description	
38	Servodrive I/O Monitor (SVIOMON)	IWC025			
		Bit	0	SIO	General input signal
			1	DEC	Deceleration dog switch
			2	P-OT	Positive limit switch input
			3	N-OT	Negative limit switch input
			4	EXT1	External input signal 1
			5	EXT2	External input signal 2
			6	EXT3	External input signal 3
	7 to 15	---	Not used.		
39	Speed Reference Output Monitor (RVMON)	ILC026	-2^{31} to $2^{31}-1$	This parameter indicates the travel distance every scan and is "0" when IBC0170: Machine Locked is ON. It is valid in Position Control Mode when an OWC020: Motion Command Code is used.	
41	Position Buffer Read Data (CNMON)	ILC028	-2^{31} to $2^{31}-1$	Position data from the position buffer specified at OLC038: Position Buffer Access Number is read and stored at this parameter when motion setting parameter OBC021F: Position Buffer Read turns ON. It takes about 2 scans from the time that OBC021F: Position Buffer Read turns ON until data is stored at this register. It is valid in Position Control Mode when an OWC020: Motion Command Code is used.	
43	Not used.	ILC02A	---	---	
45	Integral Output Monitor (YIMON)	ILC02C	-2^{31} to $2^{31}-1$	This parameter indicates the integral output value when position loop is used with PI control. (Refer to bit 8 of OWC021.) It is valid in Position Control Mode or Zero Point Return Mode.	
47	Calculated Reference Coordinate System Position (POS)	ILC02E	-2^{31} to $2^{31}-1$	This parameter has meaning when the motion fixed parameter: Axis Selection (bit 5 of the Motion Controller Function Selection Flags) is set to an infinite length axis (= 1). It indicates the target position for every infinite length axis scan. Refer to Position Monitoring in 11.3.1 Prerequisites for Position Control for details. It is valid in Position Control Mode when an OWC020: Motion Command Code is used.	
49	Primary Lag Monitor (LAGMON)	ILC030	-2^{31} to $2^{31}-1$	This parameter indicates (PI output - Primary lag output) and is valid in Position Control Mode or Zero Point Return Mode.	
51	Position Loop Output Monitor (PIMON)	ILC032	-2^{31} to $2^{31}-1$	This parameter indicates the position loop output value (prior to adding the calculated feed forward value). It is valid in Position Control Mode or Zero Point Return Mode.	

No.	Name	Register No.	Bit Name	Description
53	Position Monitor 2 (APOS2)	ILC034	-2^{31} to $2^{31}-1$	<p>This parameter is valid when the fixed parameter for motion command code selection has been set to enable using motion command codes. The value does not include the value of OLC006: Machine Coordinate Setting Zero Point Offset. When using this parameter, add the zero point offset converted to the current unit (reference unit or pulse). The setting of OBC02D3: Position Monitor 2 Unit Selection affects the data stored for this parameter.</p> <p>1. OBC02D3 = 0 Indicates the current monitored position in reference units. This parameter cannot be used if the fixed parameter for unlimited axis length selection is set for an unlimited length and OLC002: Machine Coordinate Setting Zero Point Offset is not set to 0.</p> <p>2. OBC02D3 = 1 Indicates ILC008: Position Monitor converted to pulses.</p>
55	Not used.	IWC036	---	---
56	Not used.	IWC037	---	---
57	Lower-place 2 Words of Encoder Position at Shutdown	ILC038	-2^{31} to $2^{31}-1$	<p>These parameters are used for ABS system infinite length position control. Encoder position at shutdown and pulse unit position at shutdown are paired data that together are called ABS system infinite length position control information. ABS system infinite length position control information must be saved periodically to M registers using a low-speed drawing (DWGL).</p>
59	Upper-place 2 Words of encoder position at Shutdown	ILC03A	-2^{31} to $2^{31}-1$	
61	Lower-place 2 Words of Pulse Position at Shutdown	ILC03C	-2^{31} to $2^{31}-1$	
63	Upper-place 2 Words of Pulse Position at Shutdown	ILC03E	-2^{31} to $2^{31}-1$	

■ Supplemental Explanation

1. If the fixed parameter for motion command code selection has been set to enable the use of motion command codes and the motion command enable setting (OBC0008) has been set to 1 (enabled), the number of reference units will be set. The number of pulses will be set at all other times.

6.4 Parameters for SGDH SERVOPACK

6.4.1 Parameter Configurations

Parameters are comprised of the types shown in the following table. See *Appendix B Lists of Parameters*.

Type	Parameter No.	Description
Function Selection Parameters	Pn000 to Pn003	Select basic and application functions such as the type of control or the stop mode used when an alarm occurs.
Servo Gain and Other Parameters	Pn100 to Pn118	Set numerical values such as speed and position loop gains.
Position Control Constants	Pn200 to Pn205	Set position control parameters such as the reference pulse input form and gear ratio.
Speed Control Constants	Pn300 to Pn308	Set speed control parameters such as speed reference input gain and soft start deceleration time.
Torque Control Constants	Pn400 to Pn407	Set torque control parameters such as the torque reference input gain and forward/reverse torque limits.
Sequence Constants	Pn500 to Pn510	Set output conditions for all sequence signals and changes I/O signal selections and allocations.
Others	Pn600 to Pn601	Specify the capacity for an external regenerative resistor and reserved constants.

6.4.2 Function Selection Constants

Table 6.4 Functions Selection Constant Details

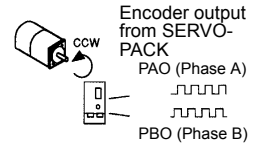
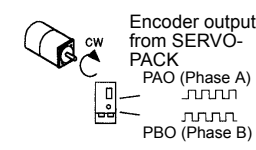
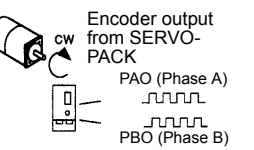
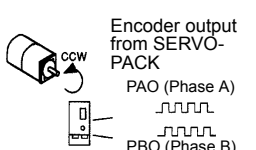
Parameter No.	Digit	Name (Setting Range)	Details	Default	Control Modes		
Pn000 Function Selection Basic Switches	0	Direction Selection (0, 1)	<p>You can change the direction of servomotor rotation without rewiring the servomotor.</p> <p>0: Forward rotation is defined as counterclockwise (CCW) rotation as viewed from the load. (Standard setting)</p> <p>1: Forward rotation is defined as clockwise (CW) rotation as viewed from the load. (Reverse Rotation Mode)</p>	0	Speed Torque Position		
						Standard Setting	Reverse Rotation Mode
			Forward Reference				
			Reverse Reference				

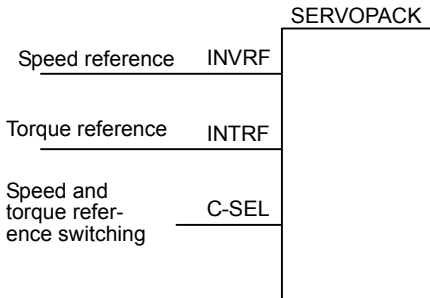
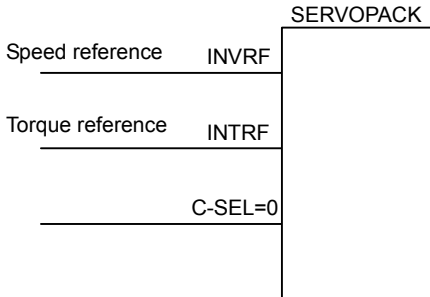
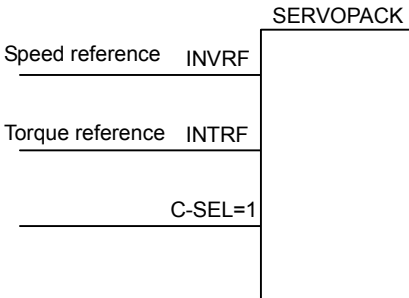
Parameter No.	Digit	Name (Setting Range)	Details	Default	Control Modes
Pn000 Function Selection Basic Switches (Contd.)	1	Control Method Selection (0 to B)	<p>SGDH SERVOPACKs can use a total of 12 different control methods, including speed control, position control, torque control, etc. When combining with an MP940, however, make sure to set the control method to 9: Torque control (analog reference) \Leftrightarrow Speed control (analog reference).</p>  <p>The above references and switching are performed automatically by the MP940 using the 2-port RAM.</p> <p>Torque control: When C-SEL is OFF</p> <ul style="list-style-type: none"> • The INTRF reference controls torque. • INVRF can be used to limit the servomotor speed when Pn002.1 is set to 1. <p>The INVRF voltage (+) limits servomotor speed during forward and reverse rotation.</p>  <p>Parameter Pn40/ can be used for maximum speed control.</p> <p>Speed control: When C-SEL is ON</p> <ul style="list-style-type: none"> • The INVRF reference controls torque. • INTRF can be used to limit servomotor speed when Pn002.1 is set to 1. 	9	Speed Torque Position
	2	Axis Address	Cannot be used with MP940. Do not touch.	0	
	3	Not used.			

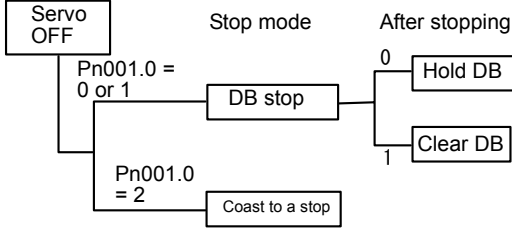
Parameter No.	Digit	Name (Setting Range)	Details	Default	Control Modes
Pn001 Function Selection Application Switches 1	0	Stop Mode when Servo Is OFF and an Alarm occurs (0, 1, 2)	<p>Select the stop method when the SERVOPACK servo is OFF in the following status during motor rotation.</p> <ul style="list-style-type: none"> • When servo ON command is OFF • When a servo alarm occurs • When the power supply is OFF <p>0: Stop using the dynamic brake. After the DB stop, hold the DB status.</p> <p>1: top using the dynamic brake. After the DB stop, clear the DB status, and allow free run.</p> <p>2: Coast to a stop. No power is supplied to the motor. The machine is stopped using friction.</p>  <pre> graph TD ServoOFF[Servo OFF] --> StopMode[Stop mode] StopMode -- "Pn001.0 = 0 or 1" --> DBstop[DB stop] StopMode -- "Pn001.0 = 2" --> Coast[Coast to a stop] DBstop -- 0 --> HoldDB[Hold DB] DBstop -- 1 --> ClearDB[Clear DB] </pre> <p>The DB (dynamic brake) function brakes the equipment electrically by consuming the motor rotation energy using resistance.</p>	0	Speed Torque Reference

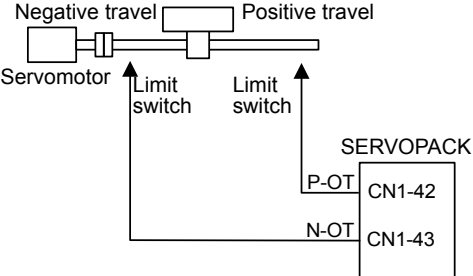
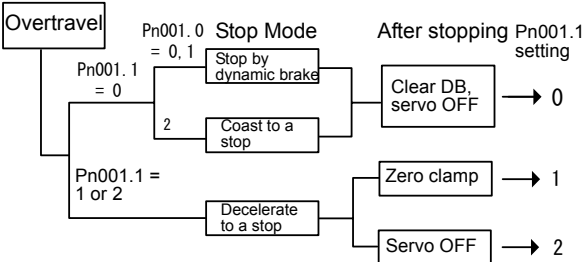
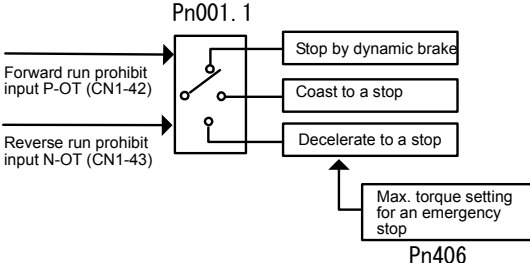
Parameter No.	Digit	Name (Setting Range)	Details	Default	Control Modes
Pn001 Function Selection Application Switches 1 (Contd.)	1	Overtravel Stop Mode (0, 1, 2)	<p>Specify the Servomotor Stop Mode when either of the following signals is input during servomotor operation.</p>  <p>0: Stops the servomotor the same way as turning the servo OFF (according to Pn001.0).</p> <p>1: Decelerates the servomotor to a stop at the preset torque, and then locks the servomotor in Zero Clamp Mode. (Torque setting: Pn406 emergency stop torque)</p> <p>2: Decelerates the servomotor to a stop at the preset torque, and puts the servomotor in coast status. (Torque setting: Pn406 emergency stop torque)</p>  	0	Speed Torque Position

Parameter No.	Digit	Name (Setting Range)	Details	Default	Control Modes																	
Pn001 Function Selection Application Switches 1 (Contd.)	1	Overtravel Stop Mode (0, 1, 2) (Contd.)	<p>Related Parameters</p> <p>Set the following parameters to specify whether input signals are used for overtravel or not.</p> <ul style="list-style-type: none"> • Pn50A.3: Use the P-OT input signal to prohibit forward rotation. • Pn50B.0: Use the N-OT input signal to prohibit reverse rotation. <div style="text-align: center;"> <p>The diagram shows a rectangular box labeled 'SERVOPACK'. Inside the box, there are two terminals: 'CN1-42 (P-OT)' and 'CN1-43 (N-OT)'. A line connects the two terminals, and another line connects the junction to a point labeled '0 V' with a downward arrow.</p> </div> <p>The short-circuit wiring shown in the figure can be omitted when P-OT and N-OT are not used.</p> <p>Set the stop torque (positive input prohibit, negative input prohibit) during overtravel.</p> <ul style="list-style-type: none"> • Pn406: Emergency stop torque 	0	Speed Torque Position																	
	2	Correspondance to DC bus (0, 1)	<p>0: Not to use with DC bus: Input AC power supply from L1, L2 and L3 terminals. Not compatible with DC power supply input: Input AC power supply from L1, L2, (L3) terminals.</p> <p>1: For use with DC bus: Input DC power supply from (+), 1, –, and (–). Compatible with DC power supply input: Input DC power supply from (+), 1 –, and (–).</p>	0																		
	3	Warning Code Output Selection (0, 1)	<p>Set if warning details are to be output using warning codes.</p> <p>0: Outputs alarm codes alone for alarm codes ALO1, ALO2 and ALO3.</p> <p>1: Outputs both alarm and warning codes for alarm codes ALO1, ALO2 and ALO3 and outputs an alarm code when an alarm occurs.</p> <p>/WARN signals: Overload and regenerative overload</p> <p>The following warning codes are output in 3 bits.</p> <table border="1" style="width: 100%; border-collapse: collapse;"> <thead> <tr> <th rowspan="2">Warning Indication</th> <th colspan="3">Warning Code Output</th> <th rowspan="2">Warning Description</th> </tr> <tr> <th>AL01</th> <th>AL02</th> <th>AL03</th> </tr> </thead> <tbody> <tr> <td>A.91</td> <td>ON signal (low level)</td> <td>OFF signal (high level)</td> <td>OFF signal (high level)</td> <td>Overload</td> </tr> <tr> <td>A.92</td> <td>OFF signal (high level)</td> <td>ON signal (low level)</td> <td>OFF signal (high level)</td> <td>Regenerative overload</td> </tr> </tbody> </table>	Warning Indication	Warning Code Output			Warning Description	AL01	AL02	AL03	A.91	ON signal (low level)	OFF signal (high level)	OFF signal (high level)	Overload	A.92	OFF signal (high level)	ON signal (low level)	OFF signal (high level)	Regenerative overload	0
Warning Indication	Warning Code Output				Warning Description																	
	AL01	AL02	AL03																			
A.91	ON signal (low level)	OFF signal (high level)	OFF signal (high level)	Overload																		
A.92	OFF signal (high level)	ON signal (low level)	OFF signal (high level)	Regenerative overload																		

Parameter No.	Digit	Name (Setting Range)	Details	Default	Control Modes
Pn001 Function Selection Application Switches 1 (Contd.)	3	Warning Code Output Selection (0, 1) (Contd.)	<p>Note: Parameter Pn50F.3 is used to allocate output terminals for *1 and *2.</p> <p>Related Parameters</p> <ul style="list-style-type: none"> • Pn50F.3 is used to allocate the /WARN output signals above. 	0	Speed Torque Position
Pn002 Function Selection Application Switches 2	0	Reserved Parameter: Speed Control Option (0, 1, 2)	<p>During speed control: When /P-CON (/C-SEL) is ON, the reference to torque reference input is the torque limit value.</p> <p>Set to 1 when connected to an MP940.</p> <p>0: Do not set.</p> <p>1: Speed control with torque limit using analog voltage reference.</p> <p>2: Do not set.</p>	1	Speed Torque Position
	1	Reserved Parameter: Torque Control Option (0, 1)	<p>During torque control: When /P-CON (/C-SEL) is OFF, the reference to speed reference input is the speed limit value.</p> <p>Set to 1 when connected to an MP940.</p> <p>0: Do not set.</p> <p>1: Torque control with speed limit using analog voltage reference.</p> <p>2: Do not set.</p>	1	
	2	Absolute Encoder Usage (0, 1)	<p>Set the absolute encoder mode.</p> <p>0: Use the absolute encoder as an absolute encoder.</p> <p>1: Use the absolute encoder as an incremental encoder.</p> <p>Related parameters</p> <ul style="list-style-type: none"> • Pn 205: Multiturn limit setting <p>Multiturn limit: Sets the upper limit for the multiturn (multiple rotation) data. When Pn002.2 = 0, the multiturn data changes within the range 0 to Pn205 (multiturn limit setting).</p>	0	
	3	Fully-closed Encoder Usage	Not used.	0	

6.4.2 Function Selection Constants

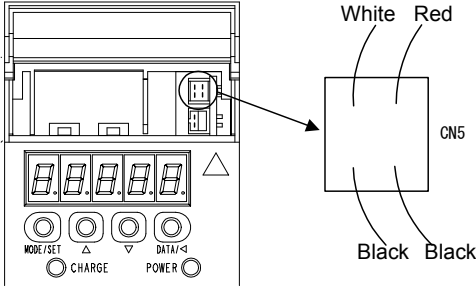
Parameter No.	Digit	Name (Setting Range)	Details	Default	Control Modes												
Pn003 Function Selection Application Switches 3	0	Analog monitor 1: Torque reference monitor (0 to 7)	 <p>You can change the analog monitor signal by setting parameters Pn003.0 and Pn003.1. If an MP940 is connected, be sure to make the following settings.</p> <ul style="list-style-type: none"> • Pn003.0: 2 Torque reference monitor • Pn003.1: 0 Motor rotation speed monitor <table border="1" data-bbox="533 810 1165 1066"> <thead> <tr> <th>Cable Color</th> <th>Signal Name</th> <th>Description</th> </tr> </thead> <tbody> <tr> <td>White</td> <td>Analog monitor 1</td> <td>Torque reference: 1 V/100% rated torque</td> </tr> <tr> <td>Red</td> <td>Analog monitor 2</td> <td>Motor r/min: 1 V/1000 r/min</td> </tr> <tr> <td>Black (two wires)</td> <td>GND (0V)</td> <td>-</td> </tr> </tbody> </table>	Cable Color	Signal Name	Description	White	Analog monitor 1	Torque reference: 1 V/100% rated torque	Red	Analog monitor 2	Motor r/min: 1 V/1000 r/min	Black (two wires)	GND (0V)	-	2	Speed Torque Control
	Cable Color	Signal Name		Description													
	White	Analog monitor 1		Torque reference: 1 V/100% rated torque													
	Red	Analog monitor 2		Motor r/min: 1 V/1000 r/min													
	Black (two wires)	GND (0V)		-													
	1	Analog monitor 2: Speed reference monitor (0 to 7)		0													
2	Reserved	0															
3	Reserved	0															
Pn004 Reserved Parameters	0 to 3	513 to 32768	Do not set.	0	Speed Torque Position												
Pn005 Function Selection Application Switches 5	0	Brake Control Function Selection (0, 1)	If connecting an MP940, be sure to set to 0. 0: Use SERVOPACK brake sequence. 1: Use host controller brake sequence.	0	Speed Torque Position												
	1	Reserved		0													
	2	Reserved		0													
	3	Reserved		0													

6.4.3 Gain-related Parameters

Table 6.5 Gain-related Parameter Table

Parameter No.	Digit	Name (Setting Range)	Details	Default	Control Modes
Pn100 Speed Loop Gain		Hz 1 to 2000	<p>This parameter determines speed loop responsiveness set within a range so that the machine does not vibrate.</p> <p>The greater the value, the more responsive speed control will be, but this is limited by the characteristics of the function.</p> <p>Speed loop gain K_v is adjusted in 1-Hz increments provided that Pn103: Inertia Ratio is set correctly.</p> <p>For inertia ratio details, refer to Pn103 Inertia Ratio.</p>	40	Speed Torque Position
Pn101 Speed Loop Integral Time Constant		0.01ms 15 to 51200	<p>The speed loop has an integral component to respond even to very small inputs. This integral component is delayed for the servo system, so the greater the time constant, the greater the positioning adjustment time, thereby worsening response. If load moment of inertia is great or the machine system includes vibrational components, the machine will vibrate unless the integral time constant is quite large. Use the following as a guideline.</p> $T_i \geq 2.3 \times \frac{1}{2\pi \times K_v}$ <p>T_i: Integral time constant (S) K_v: Speed loop gain (value calculated using 1. above) [Hz]</p>	2000	Speed Torque Position
Pn102 Position Loop Gain		1/s 1 to 2000	Do not set or use this parameter. Set the gain using SVA setting parameter OWC010:Position Loop Gain.	40	Position
Pn103 Inertia Ratio		% 0 to 10000	$\text{Inertia ratio} = \frac{\text{Motor axis conversion load moment of inertia (JL)}}{\text{Servomotor rotor moment of inertia (JM)}} \times 100 (\%)$ <p>The load moment of inertia of the SERVOPACK converted on the basis of the motor shaft is factory-set to the rotor moment of inertia of the Servomotor. Therefore, obtain the inertia ratio from the above formula and set parameter Pn103 properly.</p> <p>The above parameters are automatically set by the autotuning operation.</p>	0	Speed Torque Position
Pn104 No. 2 Speed Loop Gain		Hz 1 to 2000	<p>You can switch between using Pn100 to Pn102 or Pn104 to Pn106 for speed loop gain, speed loop integral time constant, and position loop gain, using MP940 setting parameter G-SEL reference (Gain switching OBC0012).</p> <p>OBC0012 =0: Use Pn100 to Pn102 =1: Use Pn104 to Pn106</p>	40	Speed Torque Position
Pn105 No. 2 Speed Loop Integral Time Constant		0.01ms 15 to 51200		2000	Speed Torque Position
Pn106 No. 2 Position Loop Gain		1/s 1 to 2000		40	Position
Pn107 Bias		r/min 0 to 450	Do not use this parameter when using an MP940.	0	Position

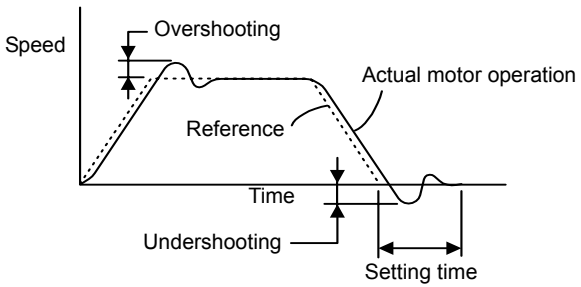
Parameter No.	Digit	Name (Setting Range)	Details	Default	Control Modes																		
Pn108 Bias Addition Width		Reference unit 0 to 250	Do not use this parameter when using an MP940.	7	Position																		
Pn109 Feed-forward		% 0 to 100	Do not use this parameter when using an MP940.	0	Position																		
Pn10A Feed-forward Filter Time Constant		0.01ms 0 to 6400	Do not use this parameter when using an MP940.	0	Position																		
Pn10B Gain-related Application Switches	0	Mode Switch Selection (0 to 4)	<p>The mode switch function makes it possible to automatically switch over the SERVOPACK's internal speed control mode from PI to P control mode and vice versa when specified conditions are satisfied.</p> <p>Use the mode switch function for the following purposes.</p> <ul style="list-style-type: none"> • To suppress overshooting during acceleration or deceleration. • To suppress undershooting during positioning and to shorten the setting time.  <p>Selecting Mode Switch Setting</p> <p>The SERVOPACK incorporates four mode switch settings (0 to 3). Select a mode switch with the following parameter (Pn10B.0).</p> <table border="1" data-bbox="550 1308 1189 1851"> <thead> <tr> <th>Setting</th> <th>Selection</th> <th>Parameter to Set Detective Point</th> </tr> </thead> <tbody> <tr> <td>0</td> <td>Uses torque reference as the detection point. (Standard setting)</td> <td>Pn10C</td> </tr> <tr> <td>1</td> <td>Uses speed reference input as the detection point.</td> <td>Pn10D</td> </tr> <tr> <td>2</td> <td>Uses acceleration as the detection point.</td> <td>Pn10E</td> </tr> <tr> <td>3</td> <td>Uses error pulse input as the detection point.</td> <td>Pn10F</td> </tr> <tr> <td>4</td> <td>Mode switch function is not used.</td> <td>---</td> </tr> </tbody> </table>	Setting	Selection	Parameter to Set Detective Point	0	Uses torque reference as the detection point. (Standard setting)	Pn10C	1	Uses speed reference input as the detection point.	Pn10D	2	Uses acceleration as the detection point.	Pn10E	3	Uses error pulse input as the detection point.	Pn10F	4	Mode switch function is not used.	---	0	Speed Torque Position
			Setting	Selection	Parameter to Set Detective Point																		
			0	Uses torque reference as the detection point. (Standard setting)	Pn10C																		
			1	Uses speed reference input as the detection point.	Pn10D																		
			2	Uses acceleration as the detection point.	Pn10E																		
			3	Uses error pulse input as the detection point.	Pn10F																		
			4	Mode switch function is not used.	---																		
Refer to explanations of Pn10C, Pn10D, and Pn10E for mode details.																							

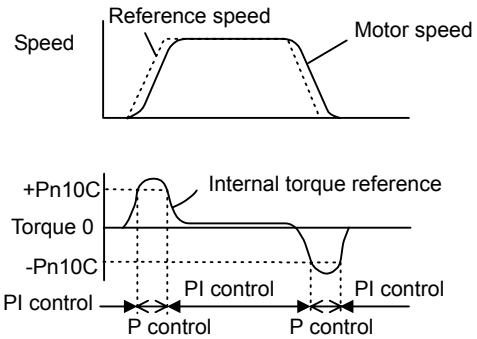
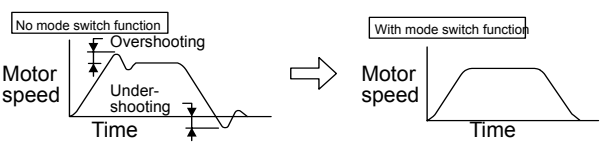
Parameter No.	Digit	Name (Setting Range)	Details	Default	Control Modes
Pn10B Gain-related Application Switches	1	IP Control (0, 1)	0: PI control 1: IP control	0	Speed Torque Position
	2	Reserved	-	0	
	3	Reserved	-	0	
Pn10C Mode Switch: Torque Reference		% 0 to 800	<p>Pn10B.0=0: Torque Reference Used as Detection Point With this setting, if the value of torque reference input exceeds the torque set in parameter Pn10C, the speed loop switches to P control.</p> <p>The SERVOPACK is factory-set to this standard mode (Pn10C = 200).</p>  <p>Operating Example If the system is always in PI control without using the mode switch function, the speed of the motor may overshoot or undershoot due to torque saturation at the time of the acceleration or deceleration of the motor. The mode switch function suppresses torque saturation and eliminates the overshooting or undershooting of the speed of the motor.</p> 	200	

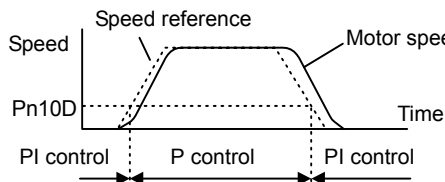
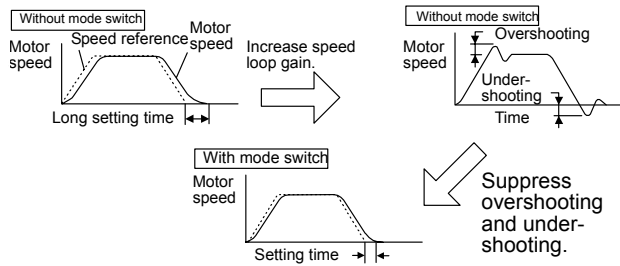
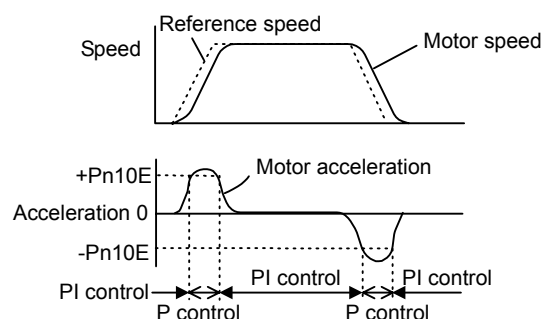
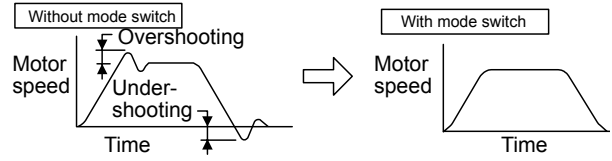
Parameter No.	Digit	Name (Setting Range)	Details	Default	Control Modes
Pn10D Mode Switch: Speed Reference		r/min 0 to 10000	<p>Pn10B.0 = 1: Speed Reference Used as Detection Point When the speed reference exceeds the speed set in parameter Pn10D, the speed loop switches to P control.</p>  <p>Operating Example In this example, the mode switch is used to reduce setting time. Generally, speed loop gain must be increased to reduce setting time. Using the mode switch suppresses the occurrence of overshooting and undershooting when speed loop gain is increased.</p> 	0	Speed Torque Position
Pn10E Mode Switch Acceleration		10/r/min/s 0 to 3000	<p>Pn10.B=2: Acceleration Used as Detection Point If motor acceleration exceeds the value set in parameter Pn10E, the speed loop switches to P control.</p>  <p>Operating Example If the system is always in PI control without using the mode switch function, the speed of the motor may overshoot or undershoot due to torque saturation at the time of the acceleration or deceleration of the motor. The mode switch function suppresses torque saturation and eliminates the overshooting or undershooting of the motor speed.</p> 	0	Speed Torque Reference

Parameter No.	Digit	Name (Setting Range)	Details	Default	Control Modes
Pn10F Mode Switch: Error Pulse		Reference unit 0 to 10000	Do not use this parameter when using an MP940.	0	Position
Pn110 Online Autotuning Switches	0	Real-time Autotuning Method (0, 1, 2)	<p>The following parameter is used for setting the autotuning conditions.</p> <p>0: Autotuning is performed only when the system runs for the first time after the power is turned ON. After the load moment of inertia is calculated, the calculated data is not refreshed. If the load moment of inertia change is minimal or if the application makes few changes, there is no need to continue calculating the moment of inertia while the system is in operation. Instead, continue to use the value that was calculated when the system was first started up.</p> <p>1: Autotuning is continuously performed (moment of inertia value calculation). Set this parameter to "1" if the load moment of inertia always fluctuates due to the load conditions. Then the response characteristics can be kept stable by continuously refreshing the moment of inertia calculation data is refreshed continuously and reflecting them in the servo gain. If the load moment of inertia fluctuation results within 200 ms, the moment of inertia calculation data may not be refreshed properly. If that happens, set Pn110.0 to "0" or "2."</p> <p>• 2: The real-time autotuning function is not used. Set Pn110.0 to "2" if autotuning is not available or if the online autotuning function is not used because the load moment of inertia is already known and the SERVOPACK is manually adjusted by setting the inertia ratio data in Pn103.</p>	2	Speed Position
	1	Speed Feed- back Com- pensation Selection (0, 1)	<p>Use the following parameter to enable or disable speed feedback compensation.</p> <p>This parameter can be left as it is if online autotuning is performed. If this parameter is set manually, however, the setting is reflected to the operational setting made during online autotuning.</p> <p>0: Enabled 1: Disabled</p> <p>Refer to Pn111: Speed Feedback Compensation.</p>	1	
	2	Friction Com- pensation Selection (0, 1, 2)	<p>If this compensation function is enabled, select small or large friction compensation according to the extent of friction in order to ensure highly precise load moment of inertia calculation.</p> <p>0: Friction compensation: Disabled 1: Friction compensation: Small 2: Friction compensation: Large</p>	0	
	3	Reserved Parameter	Do not use.	0	

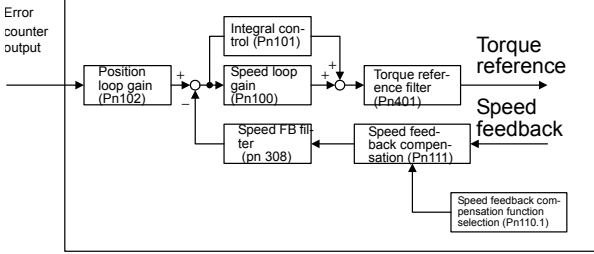
Parameter No.	Digit	Name (Setting Range)	Details	Default	Control Modes
Pn111 Speed Feedback Compensation*		% 1 to 500	<p>Use this function for shortening the setting time of the system in positioning operation.</p>  <p>Adjustment Procedure: When adding the value of speed feedback compensation, be sure to follow the procedure described below and make servo gain adjustments while watching the analog monitor to observe the position error and torque reference.</p> <ol style="list-style-type: none"> 1. Set parameter Pn110 to "0002" so that the online autotuning function will be disabled. 2. First, make normal servo gain adjustments with no feedback compensation. In this case, gradually increase the speed loop gain in Pn100 while reducing the speed loop integral time constant Pn101, and finally set the speed loop gain in Pn100 to the same value as that of the position loop gain in Pn102. <p>The relationship between the speed loop gain and integral time constant is as follows: Take the value obtained from the following formula as a reference value for setting the speed loop integral time constant in Pn101.</p> $\text{Speed loop integral time constant} = \frac{4}{2\pi \times \text{Speed loop gain[s]}} [\text{sec}]$ <p>Unit of speed loop gain [Hz]: Check the unit when setting the speed loop integral time constant in Pn101. Pn101 can be set in 0.01 ms increments.</p> <p>The unit of speed loop gain (i.e., Hz) and that of position loop gain (i.e., 1/s) are different to each other. Set these gains to the same value, however.</p> <ol style="list-style-type: none"> 3. Repeat step 2. to increase the speed loop gain while watching the position error of the analog monitor to observe the setting time and the torque reference of the analog monitor to observe any occurrence of vibration. If there is any oscillating noise or noticeable vibration, gradually increase the time constant of the torque reference filter in Pn401. 4. Gradually increase only the position loop gain. When it has been increased about as far as possible, then decrease the speed feedback compensation in Pn111 from 100% to 90%. Then repeat steps 2. and 3. 5. Decrease the speed feedback compensation to a value lower than 90%. Then repeat steps 2. through 4. to shorten the setting time. If the speed feedback compensation is too low, however, the response waveform will vibrate. 6. Find the condition in which the shortest setting time is obtainable within the range where the position error or torque reference waveform observed through the analog monitor is not vibrating or unstable. 	100	Speed Position

Parameter No.	Digit	Name (Setting Range)	Details	Default	Control Modes
Pn111 Speed Feedback Compensation*		% 1 to 500	7. The servo gain adjustment is completed when no further shortening of the positioning time is possible.	100	Speed Position

* Depending on the control mode, undetected signals are treated as OFF. For example, in the speed control mode, the /COIN signal is treated as OFF.

6.4.4 Position-related Parameters

Table 6.6 Position-related Parameter Table

Parameter No.	Digit	Name (Setting Range)	Details	Default	Control Modes
Pn200 Position Control Reference Selection Switches*	0	Reference Pulse Format	Do not use this parameter when using an MP940.	0	Position
	1	Clear Signal Format	Do not use this parameter when using an MP940.		
	2	Clear Operation	Do not use this parameter when using an MP940.		
	3	Filter Selection	Do not use this parameter when using an MP940.		
Pn201 PG Divider *		p/r 16 to 16384	Do not use this parameter when using an MP940.	16384	Speed Torque Position
Pn202 Electronic Gear Ratio* (Numerator)		1 to 65535	Do not use this parameter when using an MP940.	4	Position
Pn203 Electronic Gear Ratio* (Denominator)		1 to 65535	Do not use this parameter when using an MP940.	1	Position
Pn204 Position Reference Accel/Decel Constant		0.01ms 0 to 6400	Do not use this parameter when using an MP940.	0	Position
Pn205 Multiturn Limit Setting*		rev 0 to 65535	<ul style="list-style-type: none"> When implementing absolute detection systems for machines that turn m times in response to n turns in the load shaft, such as round tables, it is convenient to reset the multiturn data from the encoder to 0 every m turns. If the Multiturn Limit Setting is set to 65535 (factory setting), the multiturn data will vary from -32768 to 32767. If the servomotor rotates in the negative direction from 0, the multiturn data will change to the value set for Pn205. If the servomotor rotates in the positive direction from the value set in Pn205, the multiturn data will change to 0. Set Pn205 to m - 1. <p>Note: Turn the power OFF and then back ON after changing the setting of parameter Pn002.0 or Pn205.</p> <p>Related Parameters When Pn002.2 Absolute Encoder Usage is set to 0, the multiturn limit setting is enabled. 0: Use the absolute encoder as an absolute encoder. 1: Use the absolute encoder as an incremental encoder.</p>	65535	Speed Torque Position

6.4.5 Speed-related Parameters

Parameter No.	Digit	Name (Setting Range)	Details	Default	Control Modes
Pn206 Reserved parameters (Do not change.)		p/rev 5/3 to 32768	Do not use this parameter when using an MP940.	16384	Position
Pn207 Position Reference Function Switches*	0	Position Refer- ence Filter Selection	Do not use this parameter when using an MP940.	0	Position
	1	Position Refer- ence Option			
	2	Reserved			
	3	Reserved			
Pn208 Position Reference Movement Averaging Time			Do not use this parameter when using an MP940.	0	Position

* Types of /WARN signals: Overload, regenerative overload, and option warning.

6.4.5 Speed-related Parameters

Table 6.7 Speed-related Parameter Table

Parameter No.	Digit	Name (Setting Range)	Details	Default	Control Modes
Pn300 Speed Reference Input Gain		0.01V/Rated speed 150 to 3000	Do not use this parameter.	600	Speed Torque Position
Pn301 Speed 1		r/min 0 to 10000	The MP940 uses control mode selection Pn000.1=9 (torque ↔ speed), so you cannot use this parameter.	100	Speed Torque Position
Pn302 Speed 2		r/min 0 to 10000	The MP940 uses control mode selection Pn000.1=9 (torque ↔ speed), so you cannot use this parameter.	200	Speed Torque Position
Pn303 Speed 3		r/min 0 to 10000	The MP940 uses control mode selection Pn000.1=9 (torque ↔ speed), so you cannot use this parameter.	300	Speed Torque Position

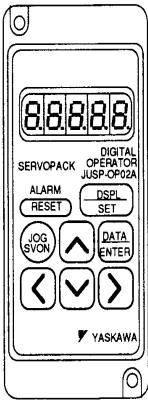
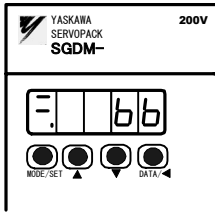
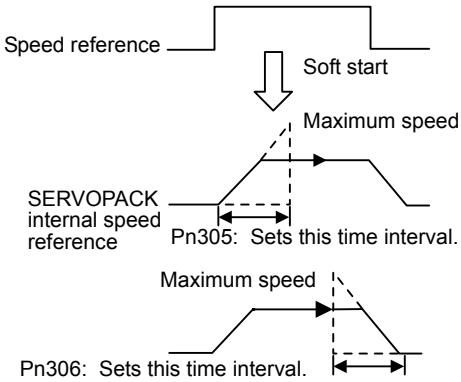
Parameter No.	Digit	Name (Setting Range)	Details	Default	Control Modes
Pn304 Jog Speed		r/min 0 to 10000	<p>Use this parameter to set the motor speed when operating the SERVOPACK from a Panel or Digital Operator. If the setting is higher than the maximum motor speed of the servomotor, then the servomotor will rotate at its maximum speed.</p> <div style="display: flex; justify-content: space-around; align-items: center;">   </div> <p style="text-align: center;">Digital Operator Panel Operator</p>	500	Speed Torque Position
Pn305 Soft Start Acceleration Time		ms 0 to 10000	<p>The SERVOPACK internal speed reference controls speed by applying this acceleration setting.</p>  <p>When inputting step-format speed reference or selecting internal setting speed, you can control the speed smoothly. In normal speed control, set this parameter to 0.</p> <ul style="list-style-type: none"> • Pn305: Time taken to accelerate from stop to maximum rotation speed. • Pn306: Time taken to decelerate from maximum rotation speed to stop. 	0	Speed
Pn306 Soft Start Deceleration Time		ms 0 to 10000			
Pn307 Speed Reference Filter Time Constant		0.01ms 0 to 65535		40	Speed
Pn308 Speed Feedback Filter Time Constant		0.01ms 0 to 65535		0	Speed

6.4.6 Torque-related Parameters

Table 6.8 Torque-related Parameter Table

Parameter No.	Digit	Name (Setting Range)	Details	Default	Control Modes
Pn400 Torque Reference Input Gain		0.1 V/rated torque 10 to 100	Do not use this parameter when using an MP940.	30	Speed Torque Position
Pn401 Torque Reference Filter Time Constant		0.01ms 0 to 65535	If there is machine vibration which may be caused by the servo-drive, try adjusting the filter time constant in Pn401. This may stop the vibration. The above constant is the filter time constant of the torque reference to be set in the SERVOPACK. The smaller the value, the faster the speed control response will be. There is, however, a certain limit depending on machine conditions.	100	Speed Torque Position
Pn402 Forward Torque Limit		% 0 to 800	Use this parameter to limit the maximum output torque to protect the machine and workpiece (internal torque limit). This parameter sets the maximum torque limits for forward and reverse rotation. The torque limit function always monitors torque and outputs the signals below when the limit is reached. The following signals are output by the torque limit function. <ul style="list-style-type: none"> • /CLT Conditions for /CLT signal output: Allocate Pn50F.0 to any of output terminals S01 to S03. • Monitor Mode Un006 The torque limits are specified as a percentage of the rated torque. Note: If torque limit is set higher than the maximum torque of the servomotor, the maximum torque of the servomotor is the limit. Application Example: Equipment Protection	800	Speed Torque Position
Pn403 Reverse Torque Limit					

Too small a torque limit will result in an insufficient torque during acceleration and deceleration.

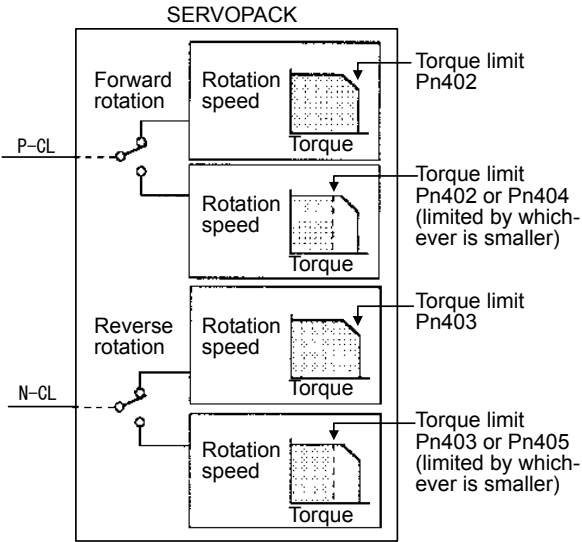
Parameter No.	Digit	Name (Setting Range)	Details	Default	Control Modes														
Pn404		%	<p>Use this parameter to limit the torque after the machine starts to move until it reaches a given position (external torque limit). A contact input signal is used to enable the torque (current) limits previously set in parameters. Torque limits can be set separately for forward and reverse rotation.</p>  <p>Input the external torque (current) limit for forward and reverse operation.</p> <table border="1" data-bbox="603 1106 1241 1570"> <tr> <td rowspan="2">P-CL</td> <td>When ON OBC0013=1</td> <td>Use forward torque limit.</td> <td>Limit: Pn404</td> </tr> <tr> <td>When OFF OBC0013=0</td> <td>Do not use forward torque limit. Normal operation.</td> <td>-</td> </tr> <tr> <td rowspan="2">N-CL</td> <td>When ON OBC0014=1</td> <td>Use reverse torque limit.</td> <td>Limit value: Pn405</td> </tr> <tr> <td>When OFF OBC0014=0</td> <td>Do not use reverse torque limit. Normal operation.</td> <td>-</td> </tr> </table>	P-CL	When ON OBC0013=1	Use forward torque limit.	Limit: Pn404	When OFF OBC0013=0	Do not use forward torque limit. Normal operation.	-	N-CL	When ON OBC0014=1	Use reverse torque limit.	Limit value: Pn405	When OFF OBC0014=0	Do not use reverse torque limit. Normal operation.	-	100	Speed Torque Position
P-CL	When ON OBC0013=1	Use forward torque limit.			Limit: Pn404														
	When OFF OBC0013=0	Do not use forward torque limit. Normal operation.	-																
N-CL	When ON OBC0014=1	Use reverse torque limit.	Limit value: Pn405																
	When OFF OBC0014=0	Do not use reverse torque limit. Normal operation.	-																
Pn405		0 to 800																	
			<p>During torque limit, the following signals are output:</p> <ul style="list-style-type: none"> • CLT=IBC001B (Servo Driver Status motion monitor parameter, bit 11.) • Monitor Mode Un005: Nos. 6 and 7 (With factory settings) Un006: Depending on output signal allocation conditions. <p>Application Examples:</p> <ul style="list-style-type: none"> • Forced stop • Robot holding a workpiece 																

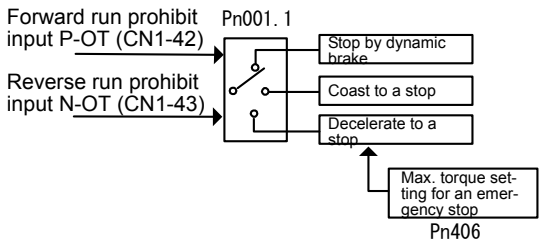
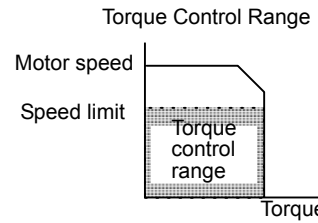
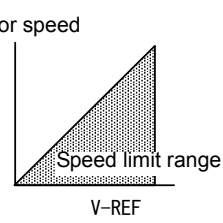
Parameter No.	Digit	Name (Setting Range)	Details	Default	Control Modes
Pn406 Emergency Stop Torque		% 0 to 800	<p>Pn406 specifies the stop torque applied for overtravel when the input signal for prohibiting forward or reverse rotation is used. This parameter is enabled when the Stop Mode during Overtravel (Pn001.1) set to 2. The torque limit is specified as a percentage of rated torque.</p>  <p>Refer to Pn001.1 for overtravel details.</p>	800	Speed Position
Pn407 Speed Limit during Torque Control		r/min 0 to 10000	<p>The parameter sets a motor speed limit when torque control is selected. It is used to prevent excessive equipment speed during torque control. Since the speed limit detection signal /VLT functions the same in torque control as the /CLT signal, where the /CLT signal is described.</p>  <p>The maximum speed of the servomotor will be used if Pn407 is set to a value higher than the maximum speed of the servomotor.</p> <p>Note: Principle of Speed Control Torque reversely proportional to the difference between the speed limit and the speed is fed back to return the system to within the control speed range when the control speed range is exceeded. The actual motor speed limit will thus be increased by negative loads.</p> 	10000	Torque
Pn408 Torque-related Function Switches	0	Notch Filter Selection	<p>Select to enable/disable notch filter function to lessen machine vibration.</p> <p>0: None 1: Notch filter used for torque reference.</p> <p>Set vibration frequency using Pn409.</p>	0	Speed Torque Position
	1	Reserved		0	
	2	Reserved		0	
	3	Reserved		0	

Parameter No.	Digit	Name (Setting Range)	Details	Default	Control Modes
Pn409 Notch Filter Frequency		Hz 50 to 2000	Set the machine vibration frequency. Enabled when Pn408.0 Select Notch Filter Function = 1.	2000	Speed Torque Position

6.4.7 Sequence-related Parameters

Table 6.9 Sequence-related Parameter Table

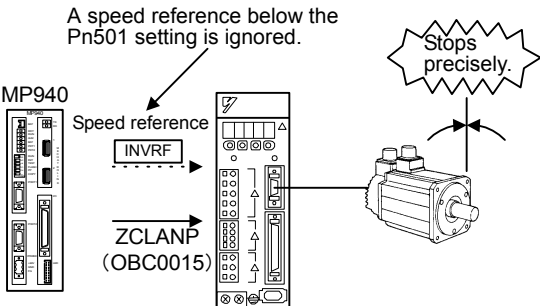
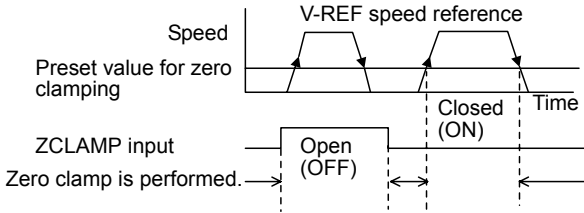
Parameter No.	Digit	Name (Setting Range)	Details	Default	Control Modes
Pn500 Positioning Completed Width		Reference unit 0 to 250	Do not use this parameter when using an MP940.	7	Position
Pn501 Zero Clamp Level		r/min 0 to 10000	<p>The zero clamp function is used for systems where the host controller does not form a position loop for the speed reference input. In other words, this function is used to stop and lock the servomotor even when the input voltage of speed reference INVRF is not 0 V. An internal position loop is temporarily formed to clamp the servomotor within one pulse when the zero clamp function is turned ON. Even if the servomotor is forcibly rotated by external force, it will still return to the zero clamp position.</p> <p>Zero Clamp Function</p> <p>This mode allows the zero clamp function to be set when the servomotor stops. The speed reference is input from INVRF. ZCLAMP(OBC0015) is used to turn the zero clamp function ON and OFF.</p> <p>ZCLAMP=0: Turns the zero clamp function OFF. ZCLAMP=1: Turns the zero clamp function ON.</p>  <p>Zero clamp is performed when the following two conditions are satisfied:</p> <p>Condition 1: ZCLAMP is ON.</p> <p>Condition 2: Speed reference is below the setting at Pn501.</p> <p>Set the motor speed at which zero clamp is performed if zero clamp speed control is selected. Even if this value is set higher than the maximum speed of the servomotor, the maximum speed will be used.</p> <p>Zero Clamp Conditions</p> <p>Zero clamp is performed when all the following conditions are satisfied:</p> <ul style="list-style-type: none"> • ZCLAMP (OBC0015) is ON (0 V). • Motor rotation speed is below this setting. 	10	Speed

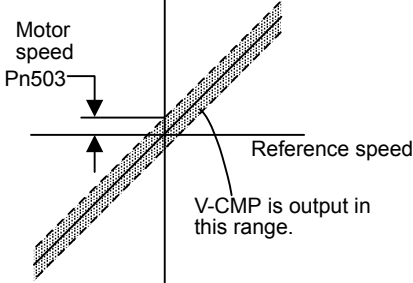
Parameter No.	Digit	Name (Setting Range)	Details	Default	Control Modes
Pn502 Rotation Detection Level		r/min 1 to 10000	<p>This parameter is used to set the speed at which the SERVOPACK determines servomotor operation and outputs a signal (TGON). The following signals are output when motor speed exceeds the preset level.</p> <p>Signals output when servomotor operation is detected:</p> <ul style="list-style-type: none"> • TGON (IBC0019) <ul style="list-style-type: none"> TGON (IBC0019) = 1: Motor rotating TGON (IBC0019) = 0: Motor stopped • Status Indication Mode • Monitor Mode Un006 	20	Speed Torque Position
Pn503 Speed Coincidence Signal Output Width		r/min 0 to 100	<p>This parameter is used to set conditions for speed coincidence signal V-CMP output.</p> <p>The V-CMP signal is output when the difference between the speed reference and actual motor speed is below this setting.</p> <p>If the set value is 100 and the reference speed is 2,000 r/min, V-CMP will turn ON between 1,900 and 2,100 r/min.</p>  <p>V-CMP (IBC0018) = 1: Speed coincides. V-CMP (IBC0018) = 0: Speed does not coincide.</p>	10	Speed
Pn504 NEAR Signal Width		Reference unit 1 to 250	Do not use this parameter when using an MP940.	7	Position
Pn505 Overflow level		Reference unit 1 to 32767	Do not use this parameter when using an MP940.	1024	Position

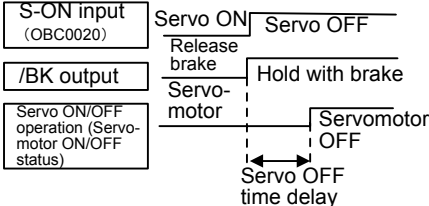
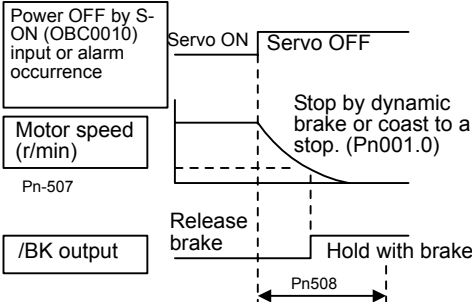
Parameter No.	Digit	Name (Setting Range)	Details	Default	Control Modes
Pn506 Brake Reference Servo OFF Delay Time		10 ms 0 to 50	<p>Brake ON Timing (Timing when motor is stopped)</p> <p>If the equipment moves slightly due to gravity when the brake is applied, set Pn506 to adjust brake ON timing.</p>	0	Speed Torque Position
Pn507 Brake Reference Output Speed Level		r/min 0 to 10000	<p>This parameter is used to set the output time from the brake control signal /BK until the servo OFF operation (servomotor output stop) when a servomotor with a brake is used.</p>	100	Speed Torque Position
Pn508 Timing for Brake Command Output during Servo OFF		10 ms 10 to 100	 <p>With the standard setting, the servo is turned OFF when the /BK signal (brake operation) is output. The equipment may move slightly due to gravity depending on equipment configuration and brake characteristics. If this happens, use this parameter to delay servo OFF timing.</p> <p>Holding Brake Setting (Brake operation when motor is rotating) Set Pn507 and Pn508 to adjust brake ON timing so the holding brake is applied when the servomotor stops. Set the brake timing used when the servo is turned OFF by input signal S-ON (OBC0010) or when an alarm occurs during servomotor with brake operation.</p>  <p>Brake ON timing when the servomotor stops must be adjusted properly because servomotor brakes are designed as holding brakes. Adjust the parameter settings while observing equipment operation.</p> <p>/BK Signal Output Conditions During Servomotor Operation The circuit is open under either of the following conditions:</p> <ul style="list-style-type: none"> • Motor speed drops below the setting at Pn507 after servo OFF. • The time set at Pn508 has elapsed since servo OFF. <p>The actual setting will be the maximum speed even if Pn507 is set higher than the maximum speed.</p>	50	Speed Torque Position

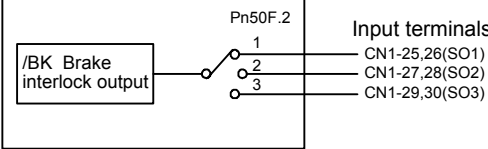
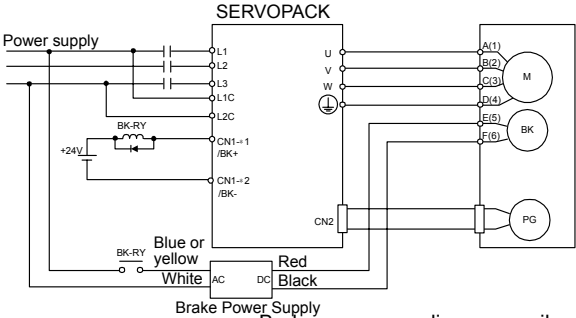
Parameter No.	Digit	Name (Setting Range)	Details	Default	Control Modes																			
Pn506		10ms 0 to 50	Related Parameters When using /BK signal, make sure to select signal output using Pn50F.2. This output signal controls the brake when using a servomotor with a brake and does not have to be connected when using a servomotor without a brake.	0	Speed Torque Position																			
Pn507		r/min 0 to 10000	<ul style="list-style-type: none"> • ON (Closed or low level): Releases the brake. • OFF (Open or high level): Applies the brake. 	100	Speed Torque Position																			
Pn508		10ms 10 to 100	 <p>• Select the terminal to which /BK is output.</p> <table border="1" data-bbox="592 774 1256 1023"> <thead> <tr> <th rowspan="2">Parameter</th> <th rowspan="2">Setting</th> <th colspan="2">Output Terminal (CN1)</th> </tr> <tr> <th>*1</th> <th>*2</th> </tr> </thead> <tbody> <tr> <td rowspan="4">Pn50F.2</td> <td>0</td> <td>-</td> <td>-</td> </tr> <tr> <td>1</td> <td>25</td> <td>26</td> </tr> <tr> <td>2</td> <td>27</td> <td>28</td> </tr> <tr> <td>3</td> <td>29</td> <td>30</td> </tr> </tbody> </table> <p>Wiring Example Use the SERVOPACK contact output signal /BK and the brake power supply to form a brake ON/OFF circuit. The following diagram shows a standard wiring example.</p>  <p>Blue or yellow White Red Black</p> <p>Brake Power Supply Brake power supplies are available in 200-V and 100-V models.</p> <p>BK-RY: Brake control relay Brake power supply is available for 100 V and 200 V.</p> <p>*1, *2: Output terminal numbers allocated by the parameter Pn50F.2.</p>	Parameter	Setting	Output Terminal (CN1)		*1	*2	Pn50F.2	0	-	-	1	25	26	2	27	28	3	29	30	50	Speed Torque Position
Parameter	Setting	Output Terminal (CN1)																						
		*1	*2																					
Pn50F.2	0	-	-																					
	1	25	26																					
	2	27	28																					
	3	29	30																					

Parameter No.	Digit	Name (Setting Range)	Details	Default	Control Modes
Pn509		ms 20 to 1000	<p>The SERVOPACK turns the servomotor OFF if it detects an instantaneous voltage drop in the power supply. This factory setting of 20 ms means that servomotor operation will continue if power is lost for less than 20 ms.</p> <p>In the following instances, however, a Servo alarm is generated or control is lost (equivalent to normal power OFF operation) regardless of the parameter setting.</p> <ul style="list-style-type: none"> • When an insufficient voltage alarm (A.41) occurs during power loss with a large servomotor load. • When control is lost (equivalent to normal power OFF operation) with loss of the control power supply. <p>In power loss detection, the status of the main circuit power supply is detected and OFF status is ignored so servomotor operation will continue if the servomotor turns back ON within the time set at parameter Pn509.</p> <p>The diagram illustrates the relationship between power supply voltage, power loss duration, and the Pn509 setting. It shows two scenarios: 1. Pn509 setting > t OFF: When power is lost for a duration less than the Pn509 setting, the servo remains ON. 2. Pn509 setting < t OFF: When power is lost for a duration longer than the Pn509 setting, the servo turns OFF. </p>	20	Speed Torque Position

■ Input Signal Selection

Table 6.10 Sequence-related Parameter Table

Parameter No.	Digit	Name (Setting Range)	Contents		Default	Control Modes
Pn50A	0	Input Signal Allocation Mode	0	Sets the input signal allocation for the sequence to the same one as for the SGDB SERVOPACK.	1	Speed Torque Position
			1	Possible to freely allocate the input signals. If an MP940 is connected, be sure to set this parameter to 1.		
	1	/SVON Signal Mapping Make sure setting is 8 (disabled)	0	Enabled when SI0 (CN1-40) input signal is ON (Low).	8: Disabled	
			1	Enabled when SI1 (CN1-41) input signal is ON (Low).		
			2	Enabled when SI2 (CN1-42) input signal is ON (Low).		
			3	Enabled when SI3 (CN1-43) input signal is ON (Low).		
			4	Enabled when SI4 (CN1-44) input signal is ON (Low).		
			5	Enabled when SI5 (CN1-45) input signal is ON (Low).		
			6	Enabled when SI6 (CN1-46) input signal is ON (Low).		
			7	Sets signal to ON.		
			8	Sets signal to OFF.		
			9	Enabled when SI0 (CN1-40) input signal is OFF (High).		
			A	Enabled when SI1 (CN1-41) input signal is OFF (High).		
			B	Enabled when SI2 (CN1-42) input signal is OFF (High).		
			C	Enabled when SI3 (CN1-43) input signal is OFF (High).		
D	Enabled when SI4 (CN1-44) input signal is OFF (High).					
E	Enabled when SI5 (CN1-45) input signal is OFF (High).					
F	Enabled when SI6 (CN1-46) input signal is OFF (High).					
2	/P-CON Signal Mapping	0 to F	Always set this parameter to 8 (Disabled).	8: Disabled		
3	P-OT Signal Mapping	0 to F	Always set this parameter to 2. Allocates /P-OT signal to SI2 (CN1-2).	2: SI2		
Pn50B	0	N-OT Signal Mapping	0 to F	Always set this parameter to 3. Allocates /N-OT signal to SI3 (CN1-43).	3: SI3	Speed Torque Position
	1	/ALM-RST Signal Mapping	0 to F	Always set this parameter to 8 (Disabled).	8: Disabled	
	2	/P-CL Signal Mapping	0 to F			
	3	/N-CL Signal Mapping	0 to F			
Pn50C	0	/SPD-D Signal Mapping	0 to F	Always set this parameter to 8 (Disabled).	8: Disabled	Speed Torque Position
	1	/SPD-A Signal Mapping	0 to F			
	2	/SPD-B Signal Mapping	0 to F			
	3	/C-SEL Signal Mapping	0 to F			

Parameter No.	Digit	Name (Setting Range)	Contents		Default	Control Modes
Pn50D	0	/ZCLAMP Signal Mapping	0 to F	Always set this parameter to 8 (Disabled).	8: Disabled	Speed Torque Position
	1	/INHIBIT Signal Mapping	0 to F			
	2	/G-SEL Signal Mapping	0 to F			
	3	Reserved	0 to F			
Pn511	0	/DEC Signal Mapping	0 to F	Always set this parameter to 1. Allocates /DEC signal to SI1 (CN1-41).	1: /DEC	Speed Torque Position
	1	/EXT1 Signal Mapping	0 to F	Always set this parameter to 4. Allocates /EXT1 signal to SI4 (CN1-44).	4: /EXT1	
	2	/EXT2 Signal Mapping	0 to F	Always set this parameter to 5. Allocates /EXT2 signal to SI5 (CN1-45).	5: /EXT2	
	3	/EXT3 Signal Mapping	0 to F	Always set this parameter to 6. Allocates /EXT3 signal to SI6 (CN1-46).	6: /EXT3	

■ Output Signal Selection

Table 6.11 Sequence-related Parameter Table

Parameter No.	Digit	Name (Setting Range)	Contents		Default	Control Modes
Pn50E	0	Positioning Completion Signal Mapping (/COIN)	0	Disabled (do not use signal on left).	0: SO1	Speed Torque Position
			1	Outputs signal on left from SO1 (CN1-25, 26).		
			2	Outputs signal on left from SO2 (CN1-27, 28).		
			3	Outputs signal on left from SO3 (CN1-29, 30).		
	1	Reserved Parameter: Speed Coincidence Detection Signal Mapping (/V-CMP)	0 to 3	—	—	
	2	/TGON Signal Mapping (/TGON)	0	Disabled (do not use signal on left).	2: SO2	
			1	Outputs signal on left from SO1 (CN1-25, 26).		
			2	Outputs signal on left from SO2 (CN1-27, 28).		
			3	Outputs signal on left from SO3 (CN1-29, 30).		
	3	/S-RDY Signal Mapping (/S-RDY)	0 to 3	Same as above.	3: SO3	

Parameter No.	Digit	Name (Setting Range)	Contents		Default	Control Modes
Pn50F	0	Torque Limit Detection Signal Mapping (/CLT)	0 to 3	Same as above.	0: Not used	Speed Torque Position
	1	Speed Control Signal Mapping (/VLT)	0 to 3	Same as above.	0: Not used	
	2	Brake Interlock Signal Mapping (/BK)	0 to 3	Same as above.	0: Not used	
	3	Warning Signal Mapping (/WARN)	0 to 3	Same as above.	0: Not used	
Pn510	0	/NEAR Signal Mapping (/NEAR)	0 to 3	Same as above.	0: Not used	Speed Torque Position
	1	Resemble C-signal Mapping (/C-PULS)	0 to 3	Same as above.	0: Not used	
	2	Reserved	-	-	0	
	3	Reserved	-	-	0	
Pn512	0	Output Signal Reversal for SO1 (CN1-25 and 26)	0	Output signal is not reversed.	0: Not reversed	Speed Torque Position
			1	Output signal is reversed.		
	1	Output Signal Reversal for SO2 (CN1-27 and 28)	0	Output signal is not reversed.	0: Not reversed	
			1	Output signal is reversed.		
	2	Output Signal Reversal for SO3 (CN1-29 and 30)	0	Output signal is not reversed.	0: Not reversed	
			1	Output signal is reversed.		
	3	Reserved	-	-	0	

Note: 1. When more than one signal is allocated to the same output circuit, data is output using OR logic.

2. Depending on the control mode, undetected signals are treated as OFF. For example, in the speed control mode, the /COIN signal is treated as OFF.

3. Types of /WARN signals: Overload, regenerative overload, and option warning.

6.4.8 Other Parameters

Parameter No.	Name (Setting Range)	Contents	Default	Control Modes
Pn600 Regenerative Resistance Capacity	10W 0 to 65535	<p>If using an external regenerative resistor, change the setting of the parameter.</p> <p>If using a SERVOPACK with or without a built-in regenerative resistor, set this parameter to its default setting (0). If an external regenerative resistor is used, set this parameter to the capacity of the regenerative resistor (W).</p> <p>Example: If the capacity of the external regenerative resistor is 100 W, set this parameter to 10.</p>	0	Speed Torque Position

7 Absolute Position Detection

This chapter describes an absolute detection system that uses an absolute encoder. Be sure to read this chapter carefully when using a servomotor equipped with an absolute encoder.

7.1 Structure of the Absolute Position Detection Function	7-2
7.1.1 Description of the Function	7-2
7.1.2 Structure of Absolute Position Detection	7-2
7.2 Starting the Absolute Position Detection Function	7-6
7.2.1 System Startup Procedure	7-6
7.2.2 Setting Related Parameters	7-7
7.2.3 Initializing the Absolute Encoder	7-8
7.2.4 Multi-turn Limit Setting	7-11
7.3 Using an Absolute Encoder	7-14
7.3.1 Finite Length Mode Axis	7-14
7.3.2 Infinite Length Mode Axis	7-18

7.1 Structure of the Absolute Position Detection Function

This section describes the Absolute Position Detection Function in the MP940.

7.1.1 Description of the Function

The Absolute Position Detection Function detects the position of the machine even if power is turned OFF. This allows it to set the machine coordinate system automatically and to begin operating automatically without having to return to the zero point after power is turned ON.

The following are features of the absolute position detection system.

- Eliminates the need to return to the zero point after power is turned ON.
- Enables the Software Limit Function immediately after power is turned ON.
- Eliminates the need for a zero point dog and overtravel limit switch.

One of the following operating systems can be selected from parameter settings with this function.

- Incremental detection system using an incremental encoder.
- Absolute position detection system using an absolute encoder.
- Incremental position detection system using an absolute encoder.

7.1.2 Structure of Absolute Position Detection

■ Basic Terminology

The following explanation for basic terminology used in this chapter is provided to ensure basic understanding.

Absolute Encoder

Absolute position detection is generally performed in a semi-closed loop using an absolute encoder built into a servomotor. The detector is comprised of an encoder that is used to detect absolute position within one rotation and a counter that is used to count the number of rotations.

Absolute Data

Absolute data that is stored in an absolute encoder is comprised of the number of rotations (N) from the absolute reference position and position (PO) in one servomotor rotation. This absolute data is read as serial data when the machine is turned ON.

All other operations are the same as that for ordinary incremental encoders.

In other words, we can determine the absolute position P using the following:

- Number of rotations from the absolute reference position: N
- Number of pulses per one servomotor rotation: RP
- Position in one servomotor rotation: PO

The absolute position (P) can be expressed as:

$$\text{Absolute position (P)} = N \times RP + PO$$

Holding Absolute Data

An absolute encoder uses a battery to maintain absolute data at all times even though power is turned OFF. It also updates data if there is a change.

■ Battery

When using an absolute encoder, you must supply a position information memory battery to the MP940 Module and SGDH SERVOPACK.

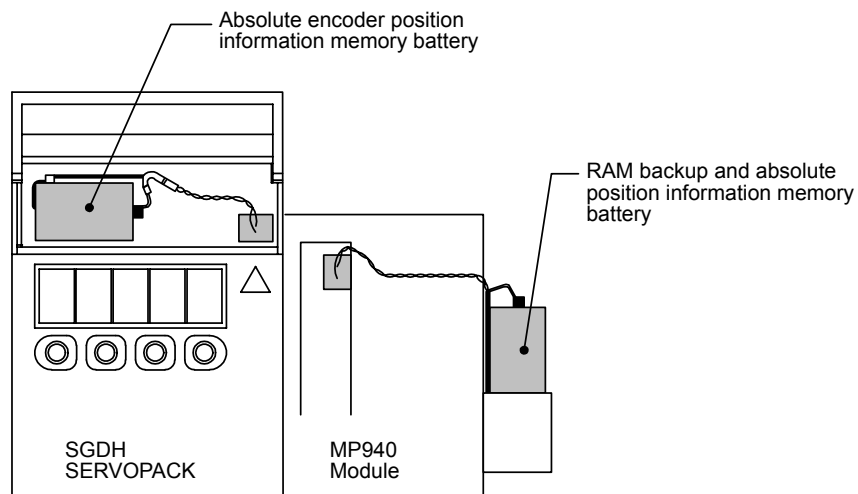

The following table shows the conditions requiring a battery.

SGDH	MP940	Application
No	No	<ul style="list-style-type: none"> Flash memory operation Using an incremental encoder Using an absolute encoder as an incremental encoder
No	Yes	<ul style="list-style-type: none"> Flash memory operation disabled Using an incremental encoder Using an absolute encoder as an incremental encoder
Yes	Yes	<ul style="list-style-type: none"> Flash memory operation Using an absolute encoder

Reading Absolute Data

When power is turned ON, absolute data is read to the SERVOPACK as well as to the MP940 where it is used to automatically calculate the absolute position and set the machine coordinate system. Therefore, the absolute machine position can be detected and automatic operation can begin immediately after power is turned ON.

■ Using Battery for the SGDH SERVOPACK

To save the absolute encoder's position information in memory even when the power supply is turned OFF, you must use a backup battery. Prepare the following recommended battery.

JZSP-BA01 Lithium battery (battery with connector)

ER3 V 3.6 V1000 mAh, manufactured by Toshiba Battery Co., Ltd.

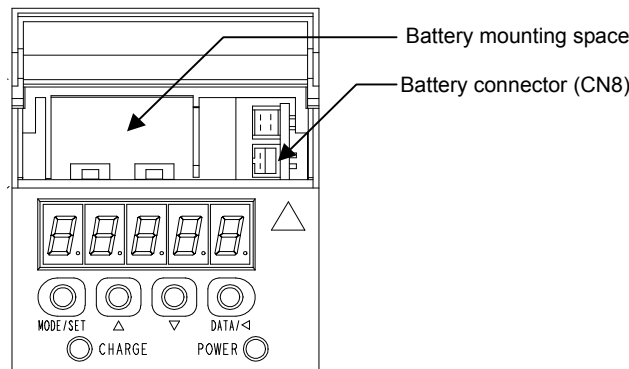

Fig 7.1 30-W to 5.0-kW SERVOPACKs

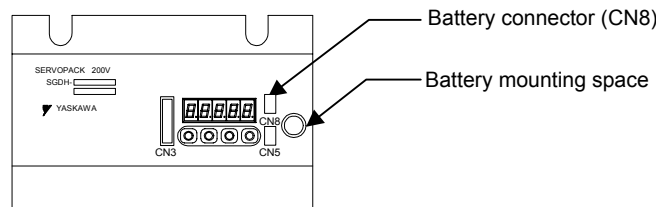

Fig 7.2 6.0-kW and 7.5-kW SERVOPACKs

■ Changes in Status in an Absolute Position Detection System

The following shows changes in status in an absolute position detection system.

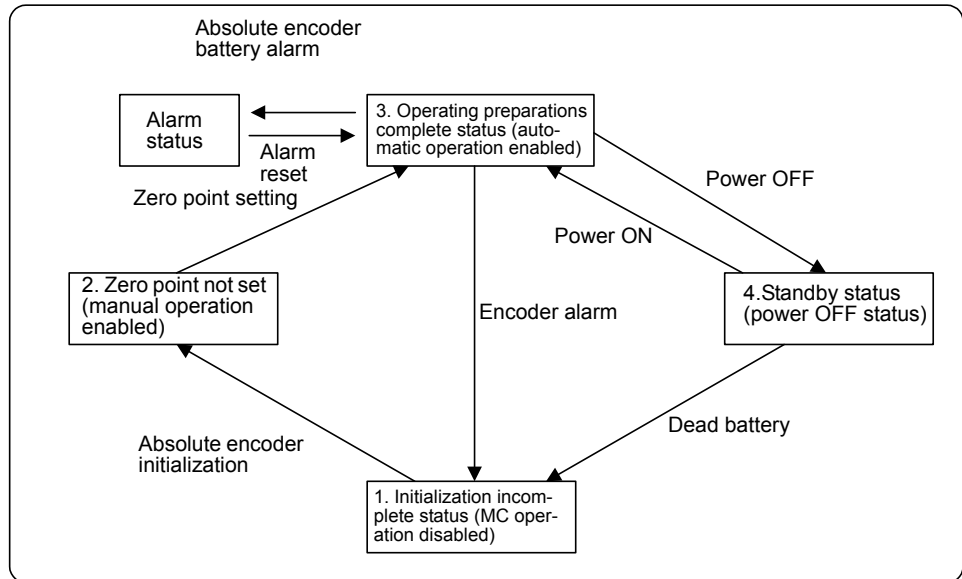

Fig 7.3 Changes in Status in the Absolute Position Detection System

The following describes the status above in more detail.

1. Initialization Incomplete Status

This status indicates that the absolute encoder operation cannot be guaranteed.

This alarm will occur if this is the first time that the absolute encoder has been used or if all backup power supplies for the absolute encoder have discharged.

Be sure to initialize the absolute encoder in these cases.

The zero point cannot be set in this status.

2. Zero Point Not Set

This status indicates that the zero point setting that is needed to determine the zero point of the machine coordinate system has not been input. In this case, an alarm will be generated when the machine is turned ON, so reset the alarm and then enter the zero point setting. If the zero point is not set, the axis can be moved only with the manual operations of JOG and STEP.

3. Operation Preparations Complete

This status indicates that zero point settings were input, the Absolute Position Detection Function is enabled and the machine is ready for normal operation.

4. Standby Status

This status indicates that machine movement is being detected even though power is OFF. Data changed by absolute encoder rotation is being updated.

At this time, the absolute encoder is running on battery power.

7.2 Starting the Absolute Position Detection Function

This section describes the procedure that is used to start the Absolute Position Detection Function.

7.2.1 System Startup Procedure

The SERVOPACK, servomotor, and other peripheral devices must be checked before starting up the absolute position detection system.

Use the following procedure to start up the system.

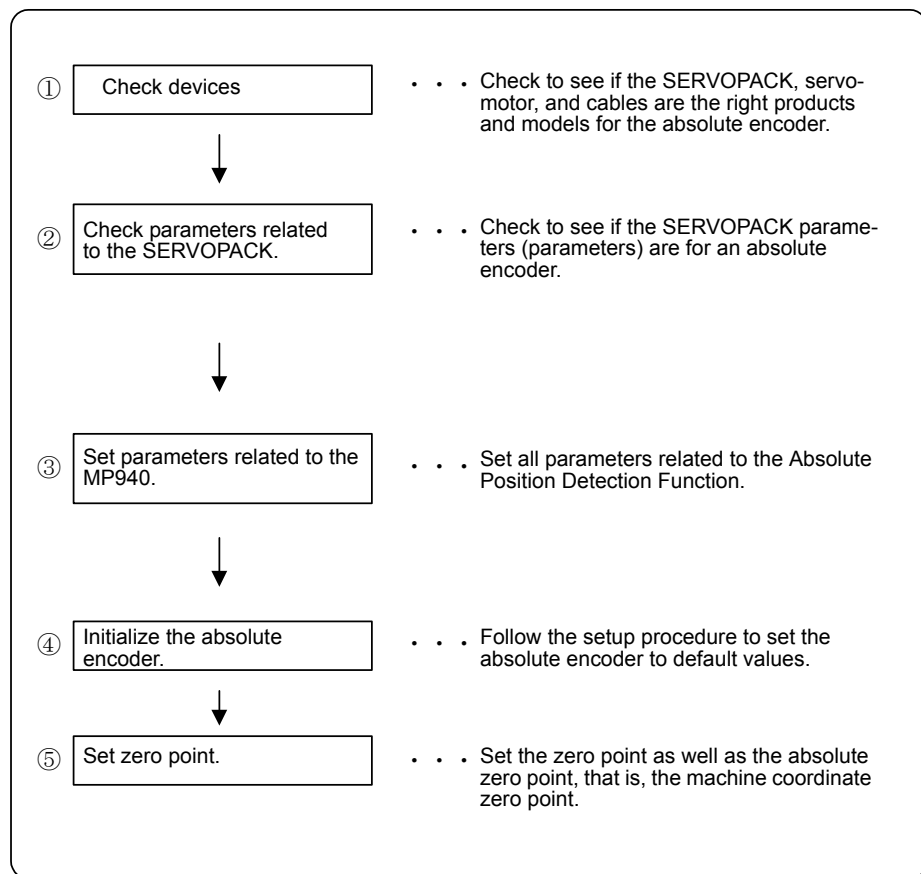

The status of the encoder will change to operation preparation complete status if steps 1 to 5 are successfully completed, and the absolute position detection system will be ready for operation.

Perform the absolute position detection system startup procedure in the following situations.

- When starting up the absolute position detection system for the first time
- When the servomotor is changed
- When an absolute encoder-related alarm occurs

7.2.2 Setting Related Parameters

This section describes absolute position detection parameters in the MP940 parameters. Set the following parameters prior to starting up the absolute position detection system.

Table 7.1 MP940 Module Parameters

Parameter No.	Name	Setting Range	Units	Initial Value
Fixed Parameter 17, b5	Axis Selection	0: Finite length axis 1: Infinite length axis	-	0
Fixed Parameter 23	Infinite Length Axis Reset Position	1 to $2^{31}-1$	1 = 1 reference unit	360000
Setting Parameter 7 (OLC006)	Machine Coordinate System Zero Point Offset Setting	0 to $\pm 2^{31}-1$	reference units	0

Table 7.2 SERVOPACK Parameters

Parameter	Name	Setting Range	Units	Initial Value
Pn002.2	Absolute Encoder Mode	0: Use the absolute encoder as an absolute encoder 1: Use the absolute encoder as an incremental encoder		0
Pn205	Multi-turn Limit Setting	0 to 65535	rev	65535

Encoder Selection (Pn202.2)

Sets the axis to perform absolute detection with the SGDH parameter Pn002.2: Absolute Encoder Mode.

Axis Selection (Fixed Parameter No. 17, Bit 5)

Sets either of the infinite or finite length mode for controlled axis movement.

Maximum Number of Absolute Encoder Rotations (Fixed Parameter No. 23)

The difference between machine coordinate values stored when power is turned OFF and machine coordinate values the next time power is turned ON is converted to pulses. If the converted number of pulses is greater than number of pulses for half the maximum number of absolute encoder rotations, an ABS Encoder Rotation Exceeded error will be generated.

Multi-turn Limit¹ Setting (Pn205)

Sets the cycle of Infinite Length Axis in reference units. This parameter is enabled when an absolute encoder is used and the Infinite Length Mode Axis is selected.

Machine Coordinate System Zero Point Offset (OLC006)

Determines the zero point position of a machine coordinate system. The meaning of this parameter depends on the type of encoder that is used and whether the finite length Mode axis or infinite length Mode axis is selected.

Finite Length Mode Axis	INC axis	Parameter (OLC006): ABS OFF is always enabled.
	ABS axis	Parameter (OLC006): ABS OFF is always enabled.
Infinite Length Mode Axis	INC axis	Parameter (OLC006): ABS OFF is always enabled.
	ABS axis	Only enabled when a zero point is set. (Used to define ABS System Infinite Length Mode Axis Control Data.)

- ABS Finite Length Mode Axis

Setting parameter OLC006: Machine Coordinate System Zero Point Offset Setting is always valid. The zero point for the machine coordinate system can be changed simply by changing this parameter. This is why the zero point does not have to be set in ABS Finite Length Mode.

- ABS Infinite Length Mode Axis

Setting parameter OLC006: Machine Coordinate System Zero Point Offset Setting is valid while the zero point is set. While the zero point is set, the positive electronic gear conversion value is used as the current machine coordinate system position.

Set the desired position at setting parameter OLC006: Machine Coordinate System Zero Point Offset Setting.

7.2.3 Initializing the Absolute Encoder

Perform the setup operation for the absolute encoder in the following conditions:

- When starting the machine for the first time.
- When an encoder backup alarm is generated.
- When the SERVOPACK's power supply is turned OFF and the encoder's cable is removed.

The setup operation can be performed by using the Hand-held Digital Operator, the SERVOPACK's Panel Operator, or the personal computer monitor software.



¹ Multi-term limit

The upper limit of multi-turn data. If Pn002.2 = 0, multi-turn data will vary between 0 and Pn205: Multi-turn Limit Setting.



The absolute encoder setup operation is only possible when the servo is OFF. After the setup processing is finished, turn the power back ON again.

■ Setup Using the Hand-held Digital Operator

1. Press the DSPL/SET Key to select the auxiliary function mode.

Fn000

2. Select the parameter Fn008. Press the Left or Right Cursor Key to select the digit to set, and then press the Up or Down Cursor Key to change the number.

Fn008

3. Press the DATA/ENTER Key. The following display will appear.

PGCL1

4. Pressing the Up Cursor Key will change the display as shown below. Continue pressing the Up Cursor Key until “-PGCL5” is displayed. If an erroneous key entry is made, “nO_OP” will flash for one second and the display will return to the auxiliary function mode. In that case, go back to step 3 above and perform the operation again.

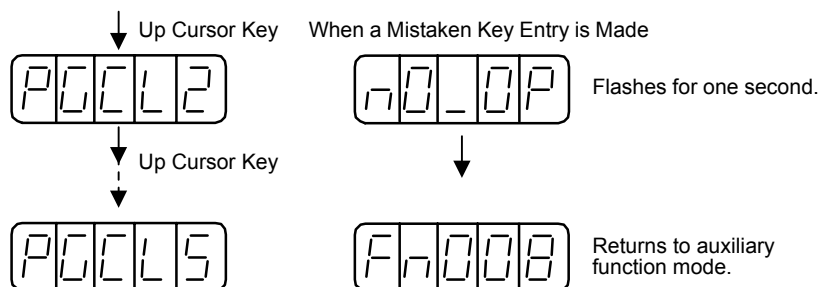

5. When “PGCL5” is displayed, press the DSPL/SET Key. The display will change as follows, and the absolute encoder's multi-turn data will be cleared.

done Flashes for 1 second. → PGCL5

6. Press the DATA/ENTER Key to return to the auxiliary function mode.

Fn008

This completes the absolute encoder's setup operation. Turn the power OFF and then back ON again.

■ Setup Using the Built-in Panel Operator

1. Press the DSPL/SET Key to select the auxiliary function mode.

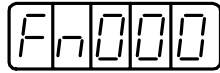

2. Press the Up or Down Cursor Key to select the parameter Fn008.



3. Press the DATA/SHIFT Key for at least one second. The following display will appear.

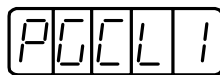

4. Pressing the Up Cursor Key will change the display as shown below. Continue pressing the Up Cursor Key until "PGCL5" is displayed. If an erroneous key entry is made, "nO_OP" will flash for one second and the display will return to the auxiliary function mode. In that case, go back to step 3 and perform the operation again.

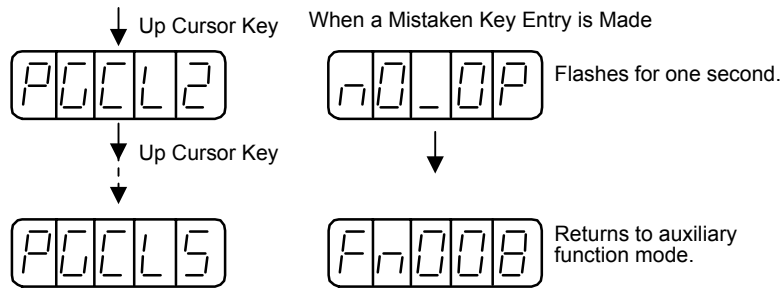

5. When "PGCL5" is displayed, press the MODE/SET Key. The display will change as follows, and the absolute encoder's multi-turn data will be cleared.

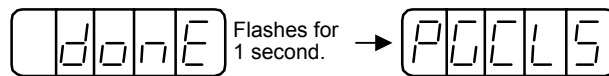

6. Press the DATA/SHIFT Key to return to the auxiliary function mode.

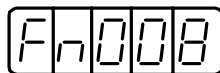

This completes the absolute encoder's setup operation. Turn the power OFF and then back ON again.

IMPORTANT

If the following absolute encoder alarms are displayed, the alarms must be cleared using the method described for the setup operation. They are not be cleared by the MP940's alarm reset (OBC0005) input signal.

- Encoder backup alarm (A.81)
- Encoder sum check alarm (A.82)

In addition, if a monitoring alarm is generated in the encoder, the alarm must be cleared by turning OFF the power.

7.2.4 Multi-turn Limit Setting

WARNING

- There is no need to change the multi-turn limit except for some special application. Changing the data unintentionally is very dangerous.
- If a multi-turn value mismatch alarm occurs, first check if the Pn205 SERVOPACK parameter is correct.

If the operation for Fn013 is performed while the value of Pn205 is still incorrect, the incorrect value will be set in the encoder. The alarm will be cancelled, but there is a danger that the machine will move to an unmeasured position by detecting a highly inaccurate position.

When implementing absolute detection systems for a machine whose motor turns m times in response to n turns in the load shaft, such as round tables, it is convenient if the multi-turn data from the encoder is reset to 0 every m turns. The Multi-turn Limit Setting allows the value m to be set for the encoder.

The use of an absolute encoder can be specified by setting the following parameter.

Pn002.2	Absolute Encoder Usage	Factory Setting: 0	Speed/Torque Control, Position Control
---------	------------------------	-----------------------	---

Pn002.2 Setting	Contents
0	Use the absolute encoder as an absolute encoder.
1	Use the absolute encoder as an incremental encoder.

Set “0” to enable the absolute encoder.

The multi-turn limit is set in the SERVOPACK using the following parameter.

Pn205	Multi-turn Limit Setting	Unit: rev	Setting Range: 0 to 65535	Factory Setting: 65535	Speed/Torque Control, Position Control
-------	--------------------------	--------------	------------------------------	---------------------------	--

If the Multi-turn Limit Setting is set to 65535 (factory setting), the multi-turn data will vary from -32768 to 32767. If any other value is set, the multi-turn data will vary from 0 to the setting of Pn205.

If the servomotor rotates in the negative direction from 0, the multi-turn data will change to the value set for Pn205. If the servomotor rotates in the positive direction from the value set in Pn205, the multi-turn data will change to 0. Set Pn205 to $m - 1$.



Turn the power OFF and then back ON after changing the setting of parameter Pn002.2 or Pn205.

The multi-turn limit value in the encoder is factory set to 65535, the same as the SERVOPACK. If the multi-turn limit value in the SERVOPACK is changed with Pn205 and then the SERVOPACK power is turned OFF and ON, the following alarm will occur.

Alarm Name: Multi-turn Limit Disagreement

Alarm Display	Alarm Code Outputs			Meaning of Alarm
	ALO1	ALO2	ALO3	
A.CC	ON	OFF	ON	The multiturn limit value is different in the Encoder and SERVOPACK.

Note: OFF: Output transistor is OFF (alarm state).
 ON: Output transistor is ON.

When this alarm occurs, the multi-turn limit in the encoder must be changed. The auxiliary function mode of the Digital Operator is used to change this setting. It can also be set from a personal computer using the Monitor Software.

The procedure to set the multi-turn limit in the encoder using the Digital Operation is provided next.



The multi-turn limit setting in the encoder can be changed only when the Multi-turn Limit Disagreement alarm has occurred. After changing the setting, turn the power supply OFF and then back ON.

■ Changing the Setting with the Hand-held Digital Operator

1. Press the DSPL/SET Key to select the auxiliary function mode.



2. Select the parameter Fn013. Press the Left or Right Cursor Key to select the digit to set, and then press the Up or Down Cursor Key to change the number.



3. Press the DATA/ENTER Key. The following display will appear.

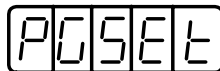

4. Press the DSPL/SET Key. The following display will appear and the multi-turn limit setting in the absolute encoder will be changed.

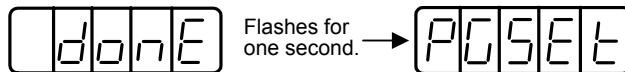

5. Press the DATA/ENTER Key to return to the auxiliary function mode.



This completes the procedure to change the multi-turn limit setting in the absolute encoder. Turn the power supply OFF and then back ON.

■ Changing the Setting with the Built-in Panel Operator

1. Press the DSPL/SET Key to select the auxiliary function mode.

The LCD display shows the text "Fn000" in a segmented font, indicating the auxiliary function mode.

2. Press the Up or Down Cursor Key to select the parameter Fn013.

The LCD display shows the text "Fn013" in a segmented font, indicating the selected parameter.

3. Press the DATA/SHIFT Key for at least one second. The following display will appear.

The LCD display shows the text "PGSEt" in a segmented font, indicating the parameter setting mode.

4. Press the MODE/SET Key. The following display will appear and the multi-turn limit setting in the absolute encoder will be changed.

The LCD display shows the text "done" in a segmented font, which flashes for one second. An arrow points to the next display, which shows "PGSEt" in a segmented font.

5. Press the DATA/SHIFT Key for at least one second to return to the auxiliary function mode.

The LCD display shows the text "Fn013" in a segmented font, indicating the auxiliary function mode.

This completes the procedure to change the multi-turn limit setting in the absolute encoder. Turn the power supply OFF and then back ON.

7.3 Using an Absolute Encoder

This section describes precautions regarding use as well as the procedure for setting the zero point when using an absolute encoder.

7.3.1 Finite Length Mode Axis

Caution

- Do not change the Zero Point Position Offset (OLC006) while operating in Finite Length Mode. Otherwise this may cause machine damage or an accident.

■ Overview

An absolute encoder stores the number of rotations from the encoder zero point in internal memory backed up by battery. Therefore, the zero point of the coordinate system can be determined without returning to the zero point when the system is started up. Once the system is started, the encoder functions just like an incremental encoder.

Unfortunately, if the number of rotations from the encoder zero point goes out of the range from -32768 to $+32767$ rotations, it is reset to 0. When system power is turned ON therefore, the MP940 position may not be the same before and after power is turned ON.

A Finite Length Mode Axis has only limited movement that falls within the range of -32768 to $+32767$ absolute encoder rotations.

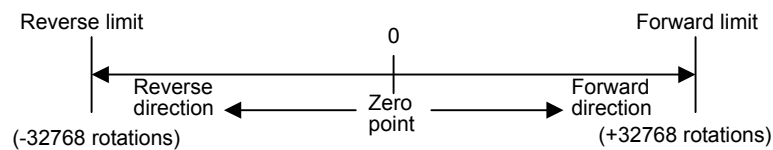

Therefore be sure to note the following precautions when using an absolute encoder as a Finite Length Mode Axis.

- Be sure to initialize the encoder prior to setting the zero point.
- Use an absolute encoder only within the range of -32768 to $+32767$ rotations.

Note: The actual machine operating range may vary depending on parameters like the gear ratio.

■ Position Control with a Finite Length Mode Axis

Initialize the axis position as described next when power is turned ON if an absolute encoder is used as a Finite Length Mode Axis.

Current position for the machine coordinate system =
Encoder position when servo power is turned ON + Setting parameter OLC006: Machine Coordinate System Zero Point* Offset

* Multi-turn data x the number of encoder pulses + initial increment

Setting parameter OLC006: Machine Coordinate System Zero Point Offset is always enabled in Finite Length Mode. This means that the current position of the machine coordinate system (zero point setting) can be changed at any time.

The meaning of setting parameter OLC006 will depend on whether Finite Length Mode or Infinite Length Mode is set.

Finite Length Mode

Set $-(ILC002) + OLC006$ at OLC006 in order to make the current position of the machine coordinate system the zero position.

◀EXAMPLE▶

$ILC002 = 10,000$ and $OLC006 = 100$

Setting the current position of the machine coordinate system to 0 when the zero point is set.

$-(10000) + 100 = -9900$ Set OLC006 to -9,900

ILC002: Monitor the calculated position of the machine coordinate system

Infinite Length Mode

Set the desired position at OLC006 and that setting will be used for the current position of the machine coordinate system when the zero point is set.

◀EXAMPLE▶

Setting the current position of the machine coordinate system to 0 when the zero point is set

Set OLC006 to 0.

■ Setting the Zero Point for a Finite Length Mode Axis

Set the zero point as described here after initializing the absolute encoder to set the zero point of the machine coordinate system and to establish the machine coordinate system.

The following illustration shows the procedure for setting the zero point for a Finite Length Mode Axis.

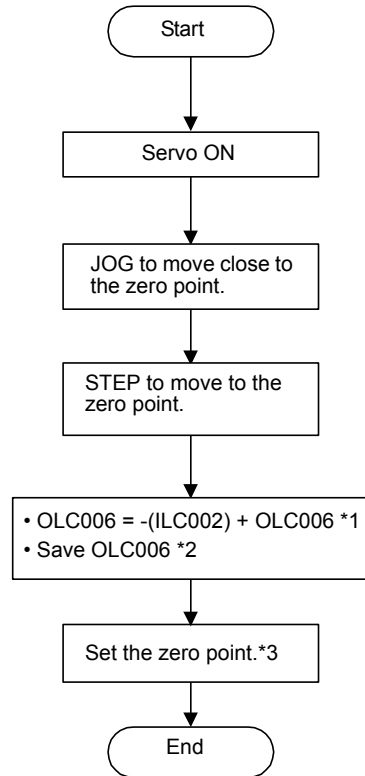

- * 1. The OLC006 value must be saved when it is set.
- * 2. See the information on the next page for more details on saving the OLC006 value.
- * 3. Execute with the ZSET command.



The following methods are used to save the Machine Coordinate System Zero Point Offset (OLC006).

- Saving in a Ladder Logic Program M Register

Calculate $(-(\text{calculated position monitored in the machine coordinate system}) + \text{the Zero Point Offset})$ and save the results in the M register when they are stored at OLC006.

Store the contents saved in M register at setting parameter OLC006: Zero Point Offset when system or servo power is turned back ON.

Ladder Logic Program Required for a Finite Length Mode Axis: ABS System Finite Length Mode Axis

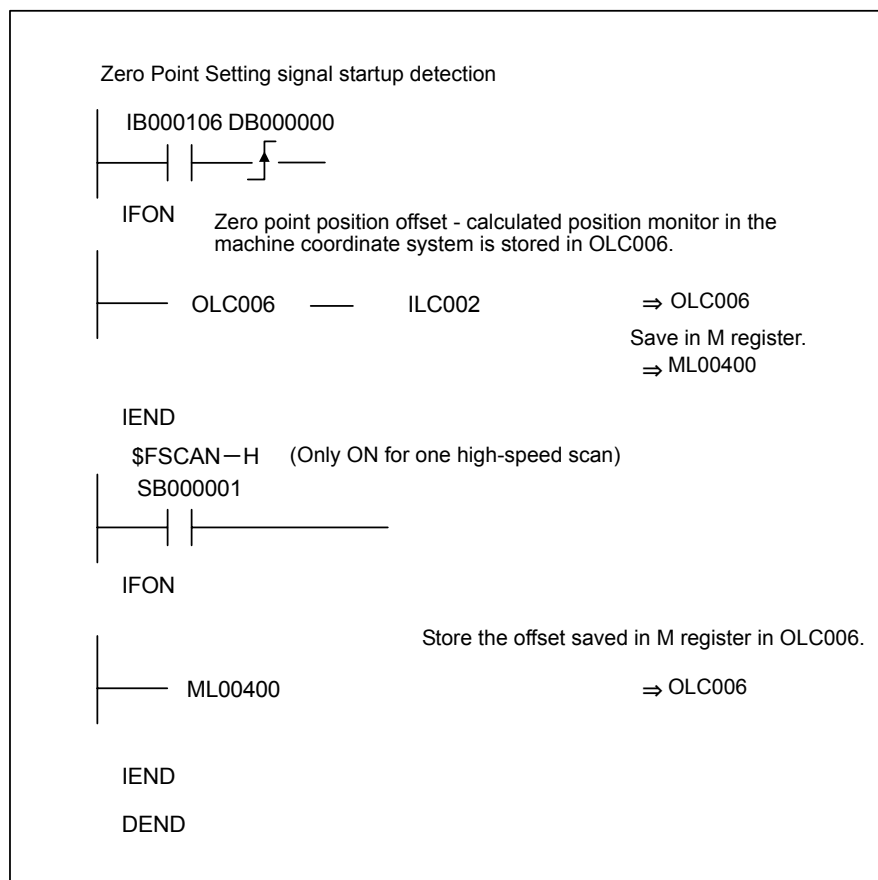

- Saving the OLC006: Machine Coordinate System Zero Point Offset from the CP-717 Parameter Screen

After the zero point and the Machine Coordinate System Zero Point Offset (OLC006) value (current value) are set, use SAVE to save the settings to the Controller. When power is turned back ON, the value that was saved for Machine Coordinate System Zero Point Offset (OLC006) will be stored automatically.

7.3.2 Infinite Length Mode Axis

■ Description

Infinite Length Positioning is a function that automatically updates machine position, program position (absolute values in a program coordinate system), and current values at regular intervals according to fixed parameter settings. The function can be used for repeated positioning in one direction.

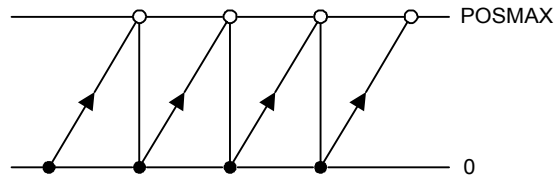

Unfortunately, if the number of rotations from the encoder zero point goes out of the range from 0 to the number set in parameter Pn 205: Multi-turn Limit Setting, it is reset to 0. When system power is turned ON, therefore, the MP940 position may not be the same before and after power is turned ON.

This problem can be resolved using the following method.

■ Position Control for an Infinite Length Mode Axis

Determine the MP940 position when power is turned ON and use the following equation to determine the pulse unit position from the relative encoder position.

Always save the pulse position and encoder position as paired data in memory backed up by battery power. This data is used as pulse position and encoder position at power OFF settings the next time power is turned ON in order to determine number of pulses from the relative encoder position using the following equation.

$$\text{Pulse position} = \text{pulse position at power OFF} + \frac{(\text{encoder position} - \text{encoder position at power OFF})}{*}$$

* Indicates the distance traveled while power is OFF (relative encoder position).



The following explains the terminology used here.

- Encoder position: Position data for an absolute encoder
(Multi-turn data × the number of encoder pulses + initial increment)
- Pulse position: MP940 position data converted to pulses.

■ Setting the Zero Point for an Infinite Length Mode Axis

Execute the ZSET motion command (zero point setting).

The system will check pulse position at power OFF, encoder position at power OFF, and all position data when the zero point is set.

The following illustration shows the procedure for setting the zero point for an Infinite Length Mode Axis.

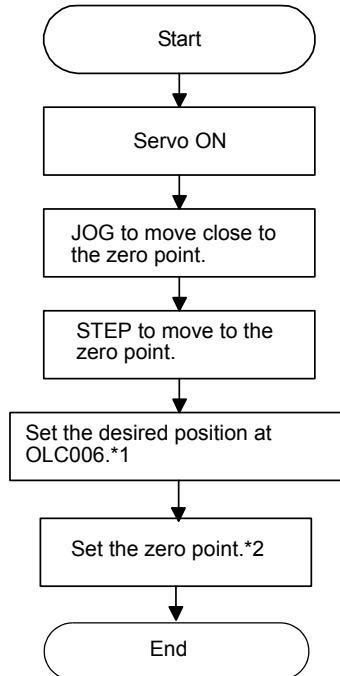

- * 1. With an Infinite Length Mode Axis, the setting parameter OLC006: Machine Coordinate System Zero Point Offset is only enabled when the ZSET command is executed. Therefore, the OLC006 value does not have to be set at the M register.

Set the desired coordinates at Machine Coordinate System Zero Point Offset (OLC006) when using an Infinite Length Mode Axis.

Example:

When setting the current stop position to 0 (zero point position for the machine coordinate system)

0 → OLC006

- * 2. Execute with the ZSET command.

■ Ladder Logic Program for Infinite Length Mode Axis Position Control

Special ladder logic programs for normal operation and for restarting the system are needed for absolute Infinite Length Mode Axis position control when an absolute encoder is used as an Infinite Length Mode Axis.

Normal Operation

1. Check the Zero Point Setting Complete status.

Check to see if monitor parameter Zero Point Setting Completed (IWC015 bit 3) is ON. If it is, go to step 2.

If it is OFF, it means that the pulse position at power OFF, encoder position at power OFF and all position data was not checked. In that case, restart the system and set up the position data again or execute the ZSET motion command (zero point setting) to check the position data all over from the start.

2. Save the pulse position at power OFF and encoder position at power OFF.

Use the customer's ladder logic program to save the following monitor parameters with high-speed scan timing at an M register backed up by battery.

Monitor parameter: Encoder Position at Power OFF (All four words at ILC038 to ILC03A)
 Monitor parameter: Pulse Position at Power OFF (All four words at ILC03C to ILC03E)

The M register that is used to save the above monitor parameters is structured as shown below.

MWxxxxx	Bit 0	Toggle Buffer Enabled Flag (0: Disabled/1: Enabled)	
	Bit 1	Toggle Buffer Selection Flag (0: Buffer 0/1: Buffer 1)	
	Bit 2	Position Data Re-setup Request Flag (0: Complete/1: Request)	
MWxxxxx +1	Not used		
MLxxxxx +2 MLxxxxx +4	Buffer 0	Monitor parameter: Encoder Position at Power OFF	Lower-place two words (ILC038) Upper-place two words (ILC03A)
		Monitor parameter: Pulse Position at Power OFF	Lower-place two words (ILC03C) Upper-place two words (ILC03E)
MLxxxxx +6 MLxxxxx +8	Buffer 1	Monitor parameter: Encoder Position at Power OFF	Lower-place two words (ILC038) Upper-place two words (ILC03A)
		Monitor parameter: Pulse Position at Power OFF	Lower-place two words (ILC03C) Upper-place two words (ILC03E)

Note: Two buffers are needed to save the encoder position and the pulse position at power OFF because the program may be exited without checking position data at all four words if power is turned OFF during the high-speed scan.

Use the following flowchart to store values in buffers.

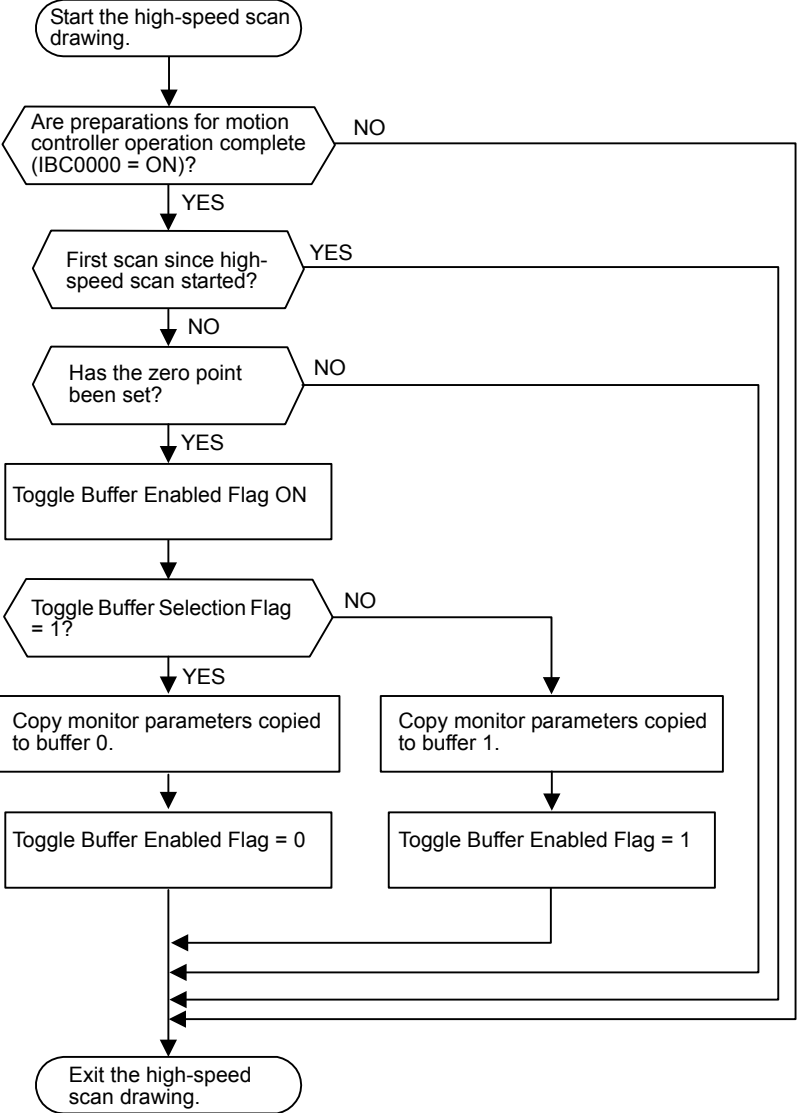

The following programming example (ladder logic program) is for the flowchart shown above. The axis used here is axis No. 1 of module No. 1. Change the motion parameter register number if the module and axis numbers are different.

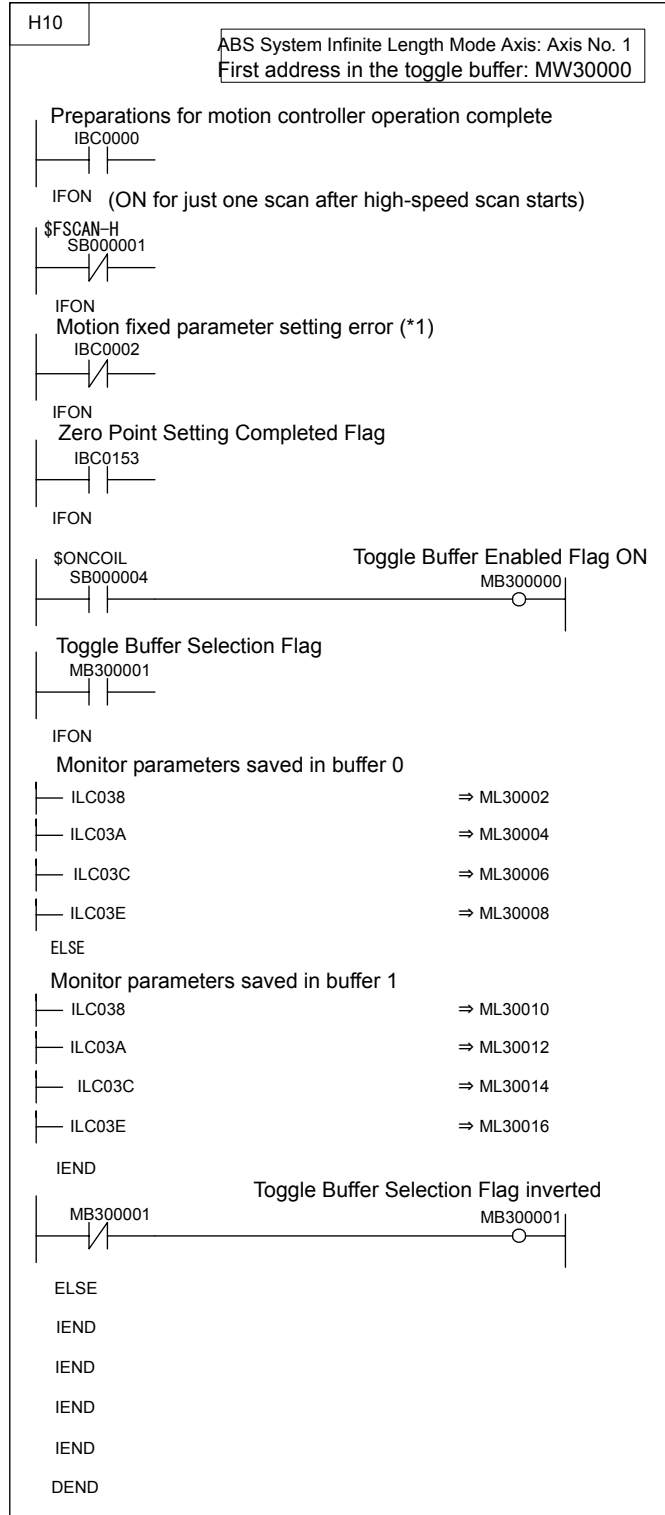

Turning the System Back ON (Turning the Servo Back ON)

Set up position data again from the customer's ladder logic program using high-speed scan timing as shown below. This is done when system power or servo power is turned back ON.

1. Store Pulse Position at Power OFF and Encoder Position at Power OFF at setting parameters.

Store the Pulse Position at Power OFF and Encoder Position at Power OFF values saved in M register at the following setting parameters.

Monitor parameter: Encoder Position at Power OFF (All four words at OLC038 to OLC03A)

Monitor parameter: Pulse Position at Power OFF (All four words at OLC03C to OLC03E)

Store the contents of the buffer selected by the previously output Toggle Buffer Selection Flag at this time.

2. ABS System Infinite Length Position Control Data LOAD Request

Turn the setting parameter: ABS System Infinite Length Position Control Data LOAD Request (OWC02D bit 2) OFF, ON and OFF again. This will allow all position data to be checked. The following monitor parameters will then be enabled when monitor parameter: Zero Point Setting Completed (IWC015 bit 3) is ON.

Monitor parameter: Encoder Position at Power OFF (All four words at ILC038 to ILC03A)

Monitor parameter: Pulse Position at Power OFF (All four words at ILC03C to ILC03E)

The system will create position data using the following equation when ABS System Infinite Length Position Control Data LOAD is requested.

$$\text{Pulse position} = \text{pulse position at power OFF} + \frac{(\text{encoder position} - \text{encoder position at power OFF})}{*}$$

* Indicates the distance traveled while power is OFF.

Execute the following flowchart when Position Data Re-Setup Request is ON.

Follow the procedure below to set up position data again.

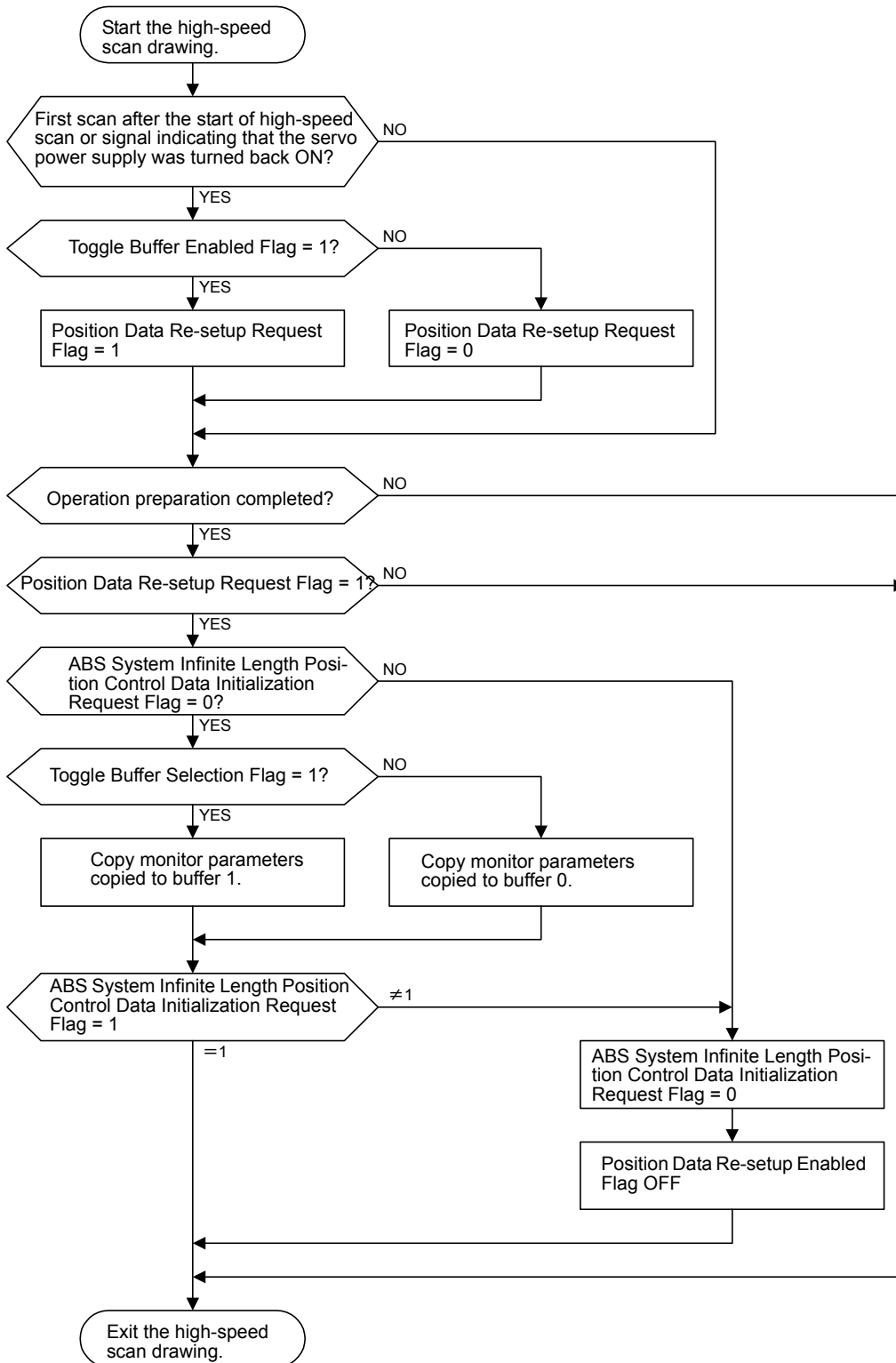

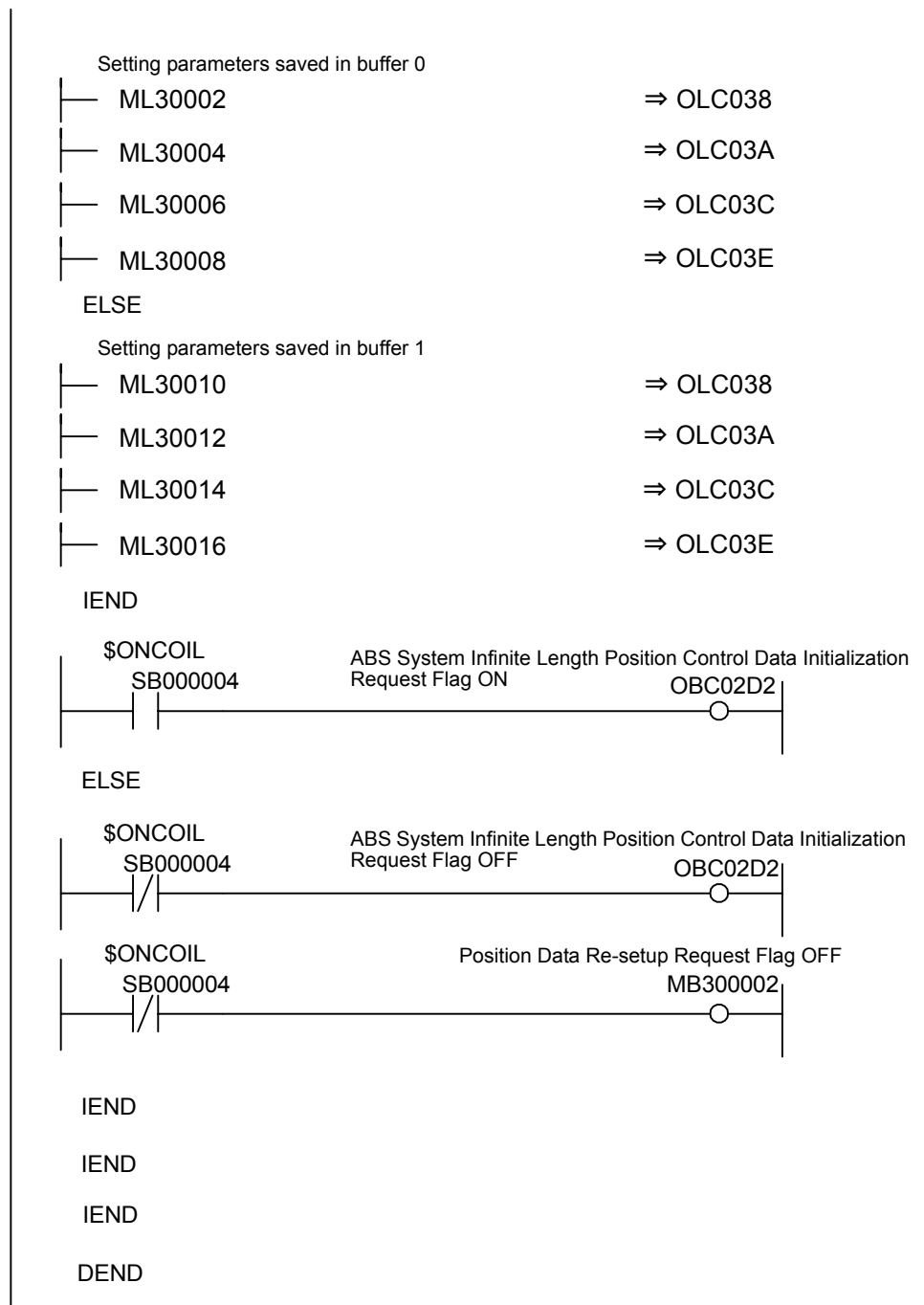

There are no restrictions in the executing order for ladder logic programs H10 and H11 when an absolute encoder is used as an Infinite Length Mode Axis.

8 Maintenance and Inspection

This chapter describes daily and regular inspection items to ensure that the MP940 can always be used at its best conditions.

8.1 Inspection Items-	8-2
8.1.1 Daily Inspections	8-2
8.1.2 Regular Inspections	8-3
8.2 MP940 Module Battery	8-4
8.2.1 Battery Life	8-4
8.2.2 Battery Replacement	8-4

8.1 Inspection Items

This section summarizes daily and regular inspection items that must be performed by the customer.

8.1.1 Daily Inspections

The following table lists the daily inspection items.

Table 8.1 Daily Inspection Items

No.	Inspection Item	Inspection Details	Criteria	Action	
1	Installation conditions of Module, etc.	Check the mounting screws for looseness. Check whether the covers are all in place.	The screws and covers must be secured correctly.	Retighten the screws.	
2	Connection conditions	Check the terminal screws for looseness.	The screws must be tight.	Retighten the screws.	
		Check the connectors for looseness.	The connectors must be tight.	Retighten the connector set screws.	
		Check the gap between crimp terminals	There must be an appropriate gap between the terminals.	Correct as necessary.	
3	Indicators	RDY indicator	Check whether the indicator is lit.	The indicator must be lit. (It is abnormal if the indicator is unlit.)	See <i>Chapter 9 Troubleshooting</i> .
		RUN indicator	Check whether the indicator is lit while the system is in RUN state.	The indicator must be lit. (It is abnormal if the indicator is unlit.)	See <i>Chapter 9 Troubleshooting</i> .
		ALM indicator	Check whether the indicator is unlit.	The indicator must be unlit. (It is abnormal if the indicator is lit.)	See <i>Chapter 9 Troubleshooting</i> .
		BAT indicator	Check whether the indicator is unlit.	The indicator must be unlit. (The battery voltage is too low if the indicator is lit.)	Replace the battery. See <i>Chapter 8.2.2 Battery Replacement</i> .
		PRT1 indicator	Check whether the indicator comes on and goes off correctly.	Serial port 1 sending.	
		PRT2 indicator	Check whether the indicator comes on and goes off correctly.	Serial port 2 sending.	

8.1.2 Regular Inspections

This section describes inspection items that must be performed once or twice every six months to one year. Inspections must also be performed when the equipment is relocated or modified or when the wiring is changed.

 Prohibited
<ul style="list-style-type: none"> Do not replace the built-in fuse. <p>If the customer replaces the built-in fuse, the MP920 may malfunction or break down. Contact your Yaskawa representative.</p>

Table 8.2 Regular Inspection Items

No.	Inspection Item	Inspection Details	Criteria	Action	
1	Operating environment	Ambient temperature	0°C to 55°C	If the MP940 is used inside a panel, treat the temperature inside the panel as the ambient temperature.	
		Ambient humidity	30% to 95%		
		Atmosphere	There must be no corrosive gases.		
2	Power supply voltage check	Measure the voltage between 24-VDC terminals.	19.2 to 28.8 VDC	Change the power supply as necessary.	
3	Installation conditions	Looseness and excess play	Attempt to move the Module.	The Module must be secured properly.	Retighten the screws.
		Dust and other foreign matter	Visually check.	The Module must be free from dust and other foreign matter.	Clean.
4	Connection conditions	Check the terminal screws for looseness.	Check by retightening the screws.	The screws must be tight.	Retighten.
		Gap between crimp terminals	Visually check.	There must be an appropriate gap between the terminals.	Correct.
		Looseness of connectors	Visually check.	The screws must be tight.	Retighten the connector set screws.
5	Battery	Check the “BAT” indicator on the front panel of the MP940 Module.	The “BAT” indicator must be unlit.	If the “BAT” indicator is lit, replace the battery.	

8.2 MP940 Module Battery

The replaceable built-in battery can be connected to the MP940 Module as an option. This battery is used to prevent the programs and data stored in the memory from being lost when a power failure occurs (i.e., when the power supply to the MP940 Module is interrupted).

8.2.1 Battery Life

The built-in battery can retain the contents of the memory until the total time of power interruptions reaches one year. The warranty period of the battery is five years from the date of purchase. These values, however, differ according to the operating conditions, including the ambient temperature.

If the BAT indicator on the MP940 Module lights, replace the battery with a replacement battery (BA000518) within two weeks. Any delay in battery replacement will result in the programs and data stored in the memory being lost.

IMPORTANT

If two weeks have passed since the BAT indicator first lit, replace the battery (model: BA000518, as an option) within one hour.

The above precaution is based on the following type of situation.

- The BAT indicator lit before a holiday, and the power supply was turned OFF during the holiday. When the power was turned ON again after the holiday, the BAT indicator was still lit.
-

8.2.2 Battery Replacement

This section describes how to replace the battery.

■ Preparations

Saving the Memory Contents

Before replacing the battery, save the programs and data from the memory of the MP940 Module to floppy disks or a hard disk. The saved programs and data will be used if the programs and data are accidentally deleted during battery replacement.

Obtain a Replacement Battery

Obtain a replacement battery (BA000518). This battery is not commercially available, and must be ordered from your nearest Yaskawa sales representative. The following diagram shows the appearance of the battery.

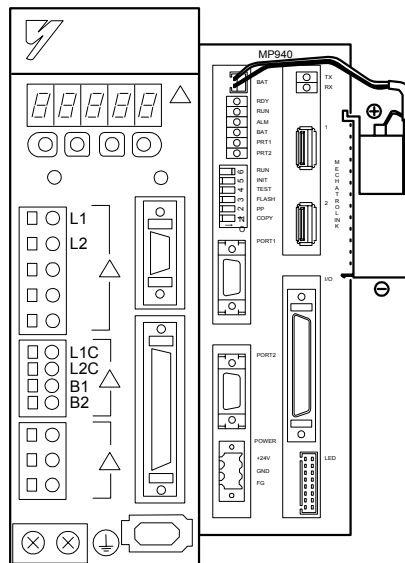

Fig 8.1 BA000518 (Battery with Cable)

■ Replacing the Battery

Use the following procedure to replace the battery.

1. Make sure that the POWER indicator on the MP940 Module is lit.
2. Remove the connector on the end of the built-in battery lead from the connector on the MP940 Module, then remove the built-in battery from the battery holder.
3. Firmly connect the connector on the end of the replacement battery lead to the connector on the MP940 Module. Then, place the replacement battery into the battery holder.
4. Make sure that the BAT indicator on the MP940 Module is unlit.

This completes the battery replacement procedure.

IMPORTANT

Be sure to replace the battery with the power supply to the MP940 Module turned ON.

Replacing the battery with the power supply to the MP940 Module turned OFF will result in the programs and data stored in the memory being lost.

9 Troubleshooting

This chapter describes the details, causes, and remedies for errors that can occur when using the system.

9.1 Overview of Troubleshooting	9-2
9.1.1 Troubleshooting Methods	9-2
9.1.2 Basic Troubleshooting Flow	9-3
9.1.3 Indicator Errors	9-3
9.2 System Errors	9-5
9.2.1 Overview of System Errors	9-5
9.2.2 Processing Flow When a System Error Occurs	9-6
9.2.3 Processing Flow When a User Program Error Occurs	9-7
9.2.4 System Register Configuration	9-8
9.3 Motion Errors	9-19
9.3.1 Description of Motion Errors	9-19
9.3.2 Processing Flow When a Motion Error Occurs	9-20

9.1 Overview of Troubleshooting

This section shows the basic troubleshooting flow and provides a list of errors.

9.1.1 Troubleshooting Methods

There are three checks available for checking the system when an error occurs. They are checks by symptoms, error codes, and monitor functions of peripheral devices. Checking procedures are categorized by status conditions to help determine the cause quickly.

■ Checking by Symptoms

Factors like indicators on the front of the Module and the control status of all devices are visually checked to determine a cause and implement corrections.

■ Checking by Error Codes

Error codes generated when errors occur are monitored to determine a cause and implement corrections. Errors are classified into two groups.

Classification	Error Code Type
Sequence Control Error Code	Starting from system register (S register) SW00040
Motion Control Error Code	<ul style="list-style-type: none"> • Motion program error code • Servo error by axis

■ Checking by Monitor Functions of Peripheral Devices

The monitor functions of peripheral devices are used to determine the control status and to find the cause of errors. The status of the following functions can be checked.

- Program monitoring
- Position monitoring
- Error monitoring
- Traces

9.1.2 Basic Troubleshooting Flow

When a problem occurs, it is important to determine the cause and treat the problem fast to get the system up and running as quickly as possible. The following table shows the basic troubleshooting flow.







No.	Point	Basic Details Examined
1	Visual Check	<ul style="list-style-type: none"> • Equipment operation (status while stopped) • Power ON/OFF • I/O equipment status • Wiring status • Status of indicators (indicators on all Modules) • Status of all switches (DIP switches and other switches) • Parameters and program content check
2	Error Check	<p>Observe whether the following alters the error in any way.</p> <ul style="list-style-type: none"> • Stopping the Controller. • Resetting the alarm. • Turning power OFF and ON.
3	Narrowing the Range	<p>Consider possible failure locations based on the results of 1 and 2 above.</p> <ul style="list-style-type: none"> • Is the problem in the Controller or external? • Is the problem in sequence control or motion control? • Is the problem software or hardware?

9.1.3 Indicator Errors

Error details can be checked by the status of indicators on the front of the MP940 Module. In the process, we narrow down the repair location in a program by getting an overview of the error from indicators, checking the contents of the system (S) registers, examining the drawing or function number that caused the error and then getting an overview of operation error details.

■ LED Indicators

The following indicators show operating status and error details for the MP940.

	RDY	Indicator Name	Indicator Color	Meaning when Lit or Flashing
	RUN			
	ALM	RDY	Green	System operating normally.
	BAT	RUN	Green	User program running.
	PRT1	ALM	Red	Lit: Minor system failure occurred. Flashing: System fault or failure occurred.
	PRT2			
		BAT	Red	Replace the battery.
		PRT1	Green	Port 1 sending.
		PRT2	Green	Port 2 sending.

■ LED Indicator Details

The following describes details and remedies for indicators showing operating status and errors in the MP940.

Classification	Indicator Name				Indicator Details	Remedy
	RDY	RUN	ALM	BAT		
Normal	Unlit	Unlit	Lit	Unlit	Hardware reset status	Normally the CPU activates within a second. If this status continues for more than a second, the problem is a user program error or hardware failure. Troubleshoot system errors.
	Unlit	Unlit	Unlit	Unlit	Initializing	
	Lit	Unlit	Unlit	Unlit	User program stopped (Offline Stop Mode)	This status will occur if a program is stopped from the CP-717 or by turning OFF the RUN switch.
	Lit	Lit	Unlit	Unlit	User program executing normally	This status will occur during normal operation.
Error	Unlit	Lit	Lit	Unlit	Serious failure has occurred	See <i>9.2.2 Processing Flow When a System Error Occurs</i> .
	Lit	Unlit	Lit	Unlit	<ul style="list-style-type: none"> Program memory initialization incomplete Improper scan time setting 	<ul style="list-style-type: none"> Clear program memory from the System Definition Screen on the CP-717. If this does not restore the system, then hardware has probably failed.
	Unlit	Unlit	Flashing	Unlit	Hardware errors No. of flashes 2: RAM diagnosis error 3: ROM diagnosis error 4: CPU function diagnosis error 5: FPU function diagnosis error	Troubleshoot system errors.
Warning	-	-	-	Lit	Battery alarm	Replace the battery.
	Lit	Lit	Lit	Unlit	Operation error	Refer to <i>User Operating Error Status</i> .
					I/O error	Refer to <i>System I/O Error Status</i> .
					Wrong interrupt occurs	
	System register warning (no indicator display)				CP-717 connection data	See System Status in <i>9.2.4 System Register Configuration</i> .
				Hardware status (power interruption, RUN/STOP, Test Mode, etc.)	See System Status in <i>9.2.4 System Register Configuration</i> .	

9.2 System Errors

This section describes system error details and remedies.

9.2.1 Overview of System Errors

Indicators on the front panel of the CPU Module indicate the operating and error status of the MP940. Use the system (S) registers to get for more details on errors. Carefully check system register details to figure out the failure location and implement corrections.

The following sections describes the system register in more detail.

■ System Register Allocation

The following illustration shows the configuration of the system registers.

SW00000	System - Service Registers	
SW00030	System Status	*
SW00050	System Error Status	*
SW00080	User Operation Status	*
SW00090	System Service Execution Status	
SW00100	Interrupt Input Error Status	
SW00110	User Operation Error Status, Details	*
SW00200	System I/O Error Status	
SW00424	Reserved for the System	
SW00500	System Analysis Status	
SW00530	Reserved for the System	
SW00600	System Operation Error Status	
SW00620	Reserved for the System	
SW00698	Interrupt Status	
SW00800	Reserved for Optional Modules	

* See 9.2.4 *System Register Configuration* for details.

9.2.2 Processing Flow When a System Error Occurs

The following illustration shows the processing flow when a system error occurs.

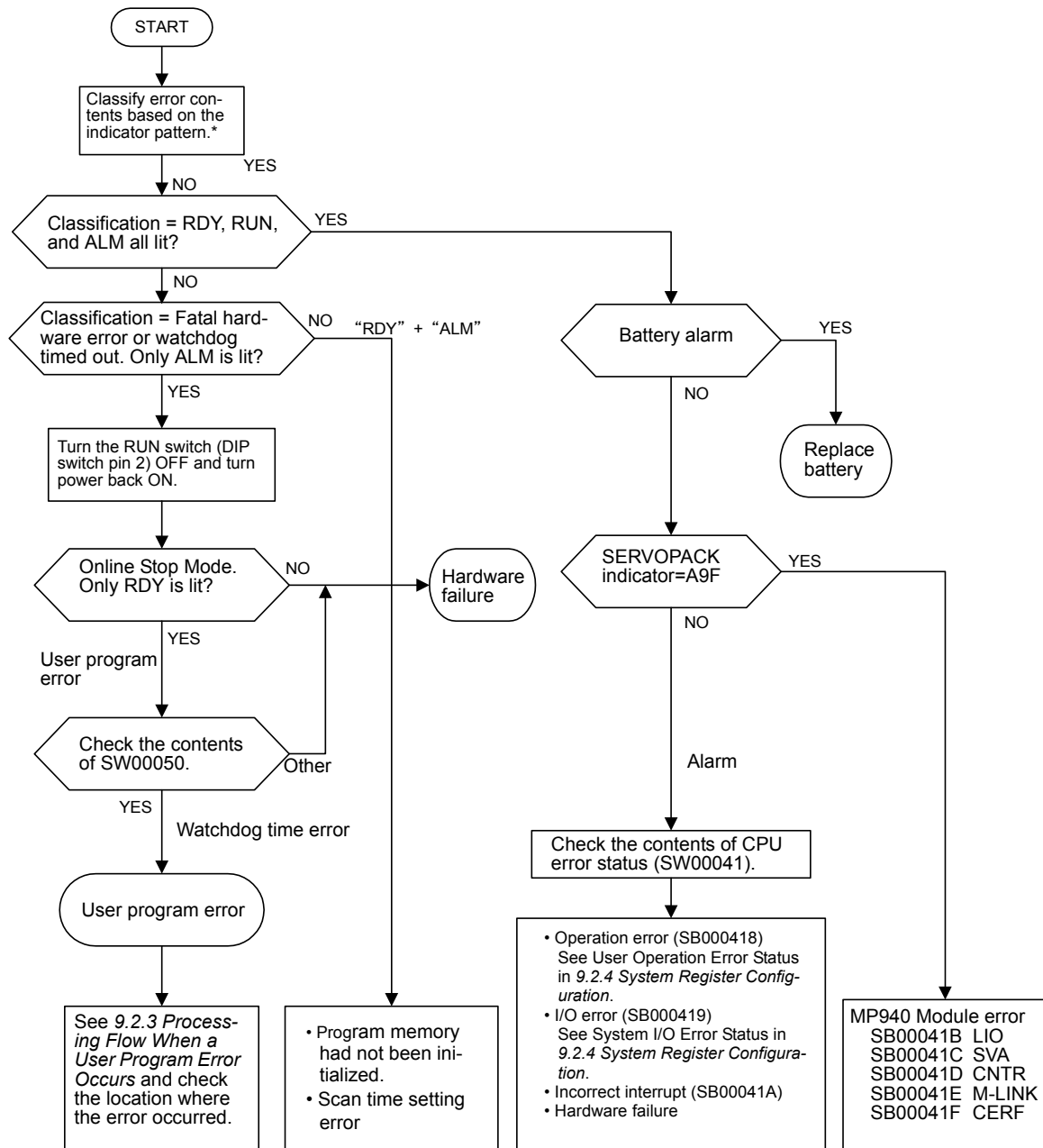

* See Indicator Details in 9.1.3 Indicator Errors for more details on indicator patterns.

9.2.3 Processing Flow When a User Program Error Occurs

A serious failure has probably occurred if the RUN and ERR indicators are lit on the front panel of the MP940. Use the following procedures to check the error program.

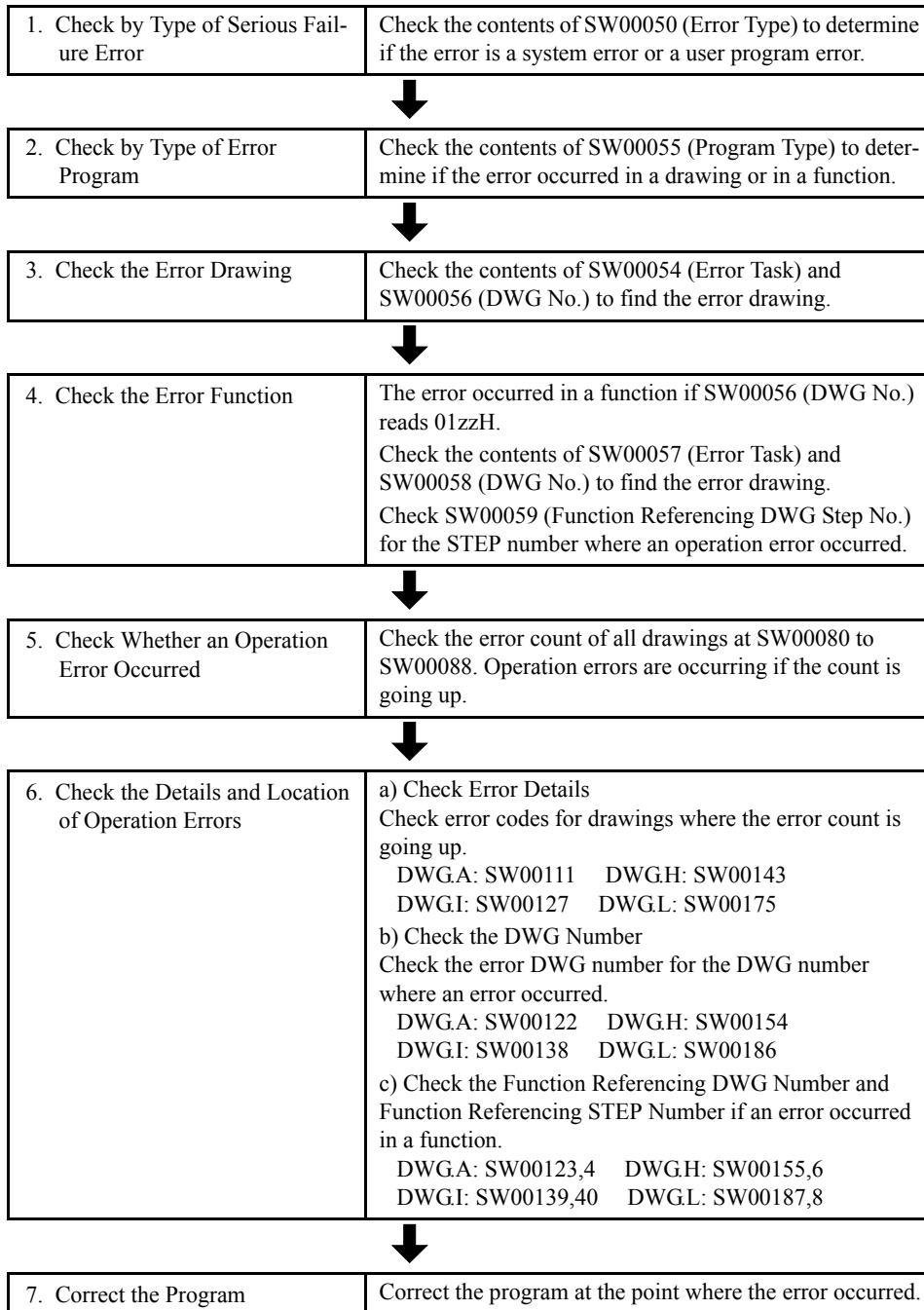

9.2.4 System Register Configuration

■ System Status

System status indicates the operating status and error details for the system. System status details are used to determine whether hardware or software is the cause of an error.

Table 9.1 System Status List

Name	Register No.	Contents		
Reserved for the System	SW00030 to SW00039	(Not used.)		
CPU Status	SW00040	SB000400	READY	1: Normal, 0: Communications/Self-diagnosis error
		SB000401	RUN	1: Running, 0: Stopped
		SB000402	ALARM	1: Alarm, 0: Normal
		SB000403	ERROR	1: Error, 0: Normal
		SB000404	RESUME	0: New startup operation
		SB000405	START STATUS	0: Ordinary restoration
		SB000406	Reserved by system.	(Not used.)
		SB000407	WEN	1: WRITE enabled, 0: WRITE disabled
		SB000408	Reserved by system.	(Not used.)
		SB000409	Reserved by system.	(Not used.)
		SB00040A	Reserved by system.	(Not used.)
		SB00040B		
		SB00040C		
		SB00040D		
		SB00040E	OPERATION STOP REQUEST	1: STOP selection, 0: RUN selection
SB00040F	Reserved by system.	(Not used.)		

Name	Register No.	Contents		
CPU Error Status	SW00041	SB000410	Serious failure	1: WDGE, undefined command See SW00050 for more details.
		SB000411	Program memory error	1: Program memory error
		SB000412		
		SB000413	Reserved by system.	(Not used.)
		SB000414		
		SB000415		
		SB000416		
		SB000417		
		SB000418	User operation error	1: User operation error
		SB000419	I/O error	1: I/O error
		SB00041A	Illegal interrupt	1: Illegal interrupt
		SB00041B	Transmission error	1: LIO communications error
		SB00041C	SVA	1: Error detected
		SB00041D	CNTR	1: Error detected
		SB00041E	Communications option (M-LINK/DeviceNet)	1: Error detected
SB00041F	CERF failure	1: Error detected		

Note: For registers SB000419, SB00041C, SB00041D, and SB00041E, refer to A.9F in 10.2.1 Troubleshooting Problems with Alarm Displays.



There are no alarm indicators on the MP940, but there is an ALARM CPU status bit. When the ERR indicator is lit, an alarm has occurred if this bit is ON.

Name	Register No.	Contents		
H scan timeout counter	SW00044	Number of H scan timeouts.		
S scan timeout counter	SW00045	Number of S scan timeouts.		
L scan timeout counter	SW00046	Number of L scan timeouts.		
Software Switch Selection Status	SW00047	SB000470	Startup mode in case of power interruption	0: New startup
		SB000471 SB000472	Reserved by system.	(Not used.)
		SB000473	Program WRITE selection	0: WRITE enabled, 1: WRITE disabled
		SB000474	Startup mode in case of ordinary power interruption	0: New startup

Name	Register No.	Contents		
Software Switch Selection Status	SW00047	SB000475	Reserved by system.	(Not used.)
		SB000476 to SB00047F	Reserved by system.	(Not used.)
Hardware Status Configuration	SW00048	SB000480	RUN	DIP switch report 0: ON 1: OFF
		SB000481	INIT	
		SB000482	TEST	
		SB000483	FLASH	
		SB000484	PP	
		SB000485	COPY	
		SB000486		
		SB000487	Battery alarm	1: Battery alarm
Reserved by System	SW00049	SB000490 to SB00049F	Reserved by system.	(Not used.)

■ System Error Status

The following table lists data when a system error status list is generated.

Table 9.2 System Error Status List

Name	Register No.	Contents	
Error Type	SW00050	0001H	Watchdog time error
		0002H	Bus time over
		0006H	Execution of a breakpoint interrupt
		0007H	Bound error (boundary check error)
		0008H	Execution of an undefined command
		000CH	Double fault
		000DH	Illogical TSS
		000EH	Segment does not exist
		000FH	Stack error
		0010H	General protection error
		0011H	Page fault
		0012H	Data alignment error
		0014H	Time slicing error
		0041H	ROM diagnosis error
		0042H	RAM diagnosis error
0043H	CPU diagnosis error		
0044H	FPU diagnosis error		
Error Code	SW00051	For system error analysis	
Error IP	SW00052	For system error analysis	
Error CS	SW00053	For system error analysis	
Error Task	SW00054	0000H: system	0003H: DWG.H
		0001H: DWG.A	0004H: DWG.S
		0002H: DWG.I	0005H: DWG.L
Program Type	SW00055	0000H: system	0004H: DWG.S
		0001H: DWG.A	0005H: DWG.L
		0002H: DWG.I	0008H: Function
		0003H: DWG.H	
0010H: Main motion program	0011H: Motion subroutine		
Error DWG No.	SW00056	Parent drawing: FFFFH, Function: 8xxxH Child drawing: xx00H (Hxx: Child drawing no.) motion program No.FxxxH Grandchild drawing: xxyyH (Hyy: Grandchild drawing No.)	
Function Calling DWG Type	SW00057	Type of DWG that calls the function in which an error occurred.	
		0001H: DWG.A	0005H: DWG.L
		0002H: DWG.I	0008H: Function
		0003H: DWG.H	0010H: Main motion program
		0004H: DWG.S	0011H: Motion subroutine

Name	Register No.	Contents	
Function Calling DWG No.	SW00058	Number of DWG that calls the function in which an error occurred. Parent drawing: FFFFH Function: 8xxxH Child drawing: xx00H (Hxx: Child drawing no.) motion program no.FxxxH Grandchild drawing: xxyyH (Hyy: Grandchild drawing no.)	
Function Calling DWG Step No.	SW00059	STEP Number of the DWG that calls the function in which an error occurred. 0 when DWG error + motion program	
Error Data	SW00060	SW00060	For system error analysis (ES)
		SW00061	For system error analysis (DS)
		SW00062	For system error analysis (DI)
		SW00063	For system error analysis (SI)
		SW00064	For system error analysis (BP)
		SW00065	For system error analysis (SP)
		SW00067	For system error analysis (DX)
		SW00068	For system error analysis (CX)
		SW00069	For system error analysis (AX)
		SW00070	Reserved by system.
		SW00071	TS1 time passage for system error analysis (1 = 0.001 ms)
		SW00072 to SW00079	Reserved by system.

■ User Operation Error Status

The following tables list data when a user operation error occurs.

Table 9.3 User Operation Error Status - 1

Name	Register No.	Contents
DWG.A Error Count Error Code	SW00080	Operation error code: See the User Operation Error Status - 3 Table below.
	SW00081	
DWG.I Error Count Error Code	SW00082	Error code when an index error occurs: See the User Operation Error Status - 4 Table below.
	SW00083	
DWG.H Error Count Error Code	SW00084	
	SW00085	
DWG.S Error Count Error Code	SW00086	
	SW00087	
DWG.L Error Count Error Code	SW00088	
	SW00089	

Table 9.4 User Operation Error Status - 2

Name	Register No.					Remarks
	DWG.A	DWG.I	DWG.H	DWG.S	DWG.L	
Error Count	SW00110	SW00126	SW00142	SW00158	SW00174	Error DWG number Parent drawing: FFFFH Child drawing: xx00H (Hxx: Child drawing no.) Grandchild drawing: xxyyH (Hyy: Grandchild drawing no.) Function: 8xxxH Motion: FxxxH Function Calling DWG Number Number of the DWG that calls the function in which an error occurred. Function Calling DWG Step No. Step No. of the DWG that calls the function in which an error occurred. This will be "0" if the error occurred inside the DWG.
Error Code	SW00111	SW00127	SW00143	SW00159	SW00175	
Error A Register	SW00112	SW00128	SW00144	SW00160	SW00176	
	SW00113	SW00129	SW00145	SW00161	SW00177	
Modification A Register	SW00114	SW00130	SW00146	SW00162	SW00178	
	SW00115	SW00131	SW00147	SW00163	SW00179	
Error F Register	SW00116	SW00132	SW00148	SW00164	SW00180	
	SW00117	SW00133	SW00149	SW00165	SW00181	
Modification F Register	SW00118	SW00134	SW00150	SW00166	SW00182	
	SW00119	SW00135	SW00151	SW00167	SW00183	
Error IP	SW00120	SW00136	SW00152	SW00168	SW00184	
Error CS	SW00121	SW00137	SW00153	SW00169	SW00185	
Error DWG No.	SW00122	SW00138	SW00154	SW00170	SW00186	
Function Calling DWG Type	SW00123	SW00139	SW00155	SW00171	SW00187	
Function Calling DWG Step No.	SW00124	SW00140	SW00156	SW00172	SW00188	
Reserved by System	SW00125	SW00141	SW00157	SW00173	SW00189	

Table 9.5 User Operation Error Status - 3

	Error Code	Error Contents	User	System Default
Integer Operation	0001H	Integer operation - underflow	Yes	-32768 [-32768]
	0002H	Integer operation - overflow	Yes	32767 [32767]
	0003H	Integer operation - division error	Yes	The A register remains the same.
	0009H	Double integer operation - underflow	Yes	-2147483648 [-2147483648]
	000AH	Double integer operation - overflow	Yes	2147483647 [2147483647]
	000BH	Double integer operation - division Error	Yes	The A register remains the same.
	010xH	Integer operation error within operation error processing drawing (x = 1 to B)	No	Default indicated above.

	Error Code	Error Contents	User	System Default	
Real Number Operation	0010H	Integer storage - non-numeric error	Yes	Store not executed. [00000]	
	0011H	Integer storage - underflow	Yes	Store not executed. [-32768]	
	0012H	Integer storage - overflow	Yes	Store not executed. [+32767]	
	0021H	Real number storage - underflow	Yes	Store not executed. [-1.0E+38]	
	0022H	Real number storage - overflow	Yes	Store not executed. [1.0E+38]	
	0023H	Real number operation - division-by-zero error	Yes	Operation not executed. The F register remains the same.	
	0030H	Real number operation - invalid operation (non-numeric)	No	Operation not executed.	
	0031H	Real number operation - exponent underflow	No	0.0	
	0032H	Real number operation - exponent overflow	No	Maximum value	
	0033H	Real number operation - division error (non-numeric 0/0)	No	Operation not executed.	
	0034H	Real number storage - exponent underflow	No	Stores 0.0.	
0035H	Real number operation - stack error				
Real Number Operation	0040H to 0059H	Real number operation error within a standard system function		No	Interrupt operation and output = 0.0
		0040H: SQRT	0041H: SIN	0042H: COS	0043H: TAN
		0044H: ASIN	0045H: ACOS	0046H: ATAN	0047H: EXP
		0048H: LN	0049H: LOG	004AH: DZA	004BH: DZB
		004CH: LIM	004DH: PI	004EH: PD	004FH: PID
		0050H: LAG	0051H: LLAG	0053H: FGN	0054H: IFGN
		0054H: LAU	0055H: SLAU	0056H: REM	0057H: RCHK
		0058H: BSRCH	0059H: SQRT		
	1000H or 2000H is added for an index error.				
	Operation error in a motion function The number of the function where the error occurred + 200H will be stored.				
	0200H: MOV	0201H: MVS	0202H: MCC	0203H: MCW	
	0204H:	0205H: SKP	0206H:	0207H:	
	0208H: POS	0209H:	020AH: ACC	020BH: DCC	
	020CH: SCC	020DH: VEL	020EH: INP	020FH: IAC	
	0210H: IDC	0211H: IFP	0212H: FMX	0213H:	
	0214H: MVT	0215H: EXM			

Table 9.6 User Operation Error Status - 4

	Error Code	Error Contents	User	System Default				
Integer - Real Number Operations	1000H	Index error within DWG	No	Re-executed with i, j = 0				
	2000H	Index error within function	No	Re-executed with i, j = 0				
Integer Operation	x060H to x077H (x = 1, 2)	Index error within integer system function	No	The A register remains the same.				
					x06DH: PI	x06DH: PD	x06FH: PID	x070H: LAG
					x071H: LLAG	x072H: FGN	x073H: IFGN	x074H: LAU
					x075H: SLAU	x076H: FGN	x077H: IFGN	

■ System Service Execution Status

Name	Register No.	Remarks
System Error Count	SW00090	
System Error Code	SW00091	
Failure Occurrence Count	SW00092	
Failure Restoration Count	SW00093	
Reserved by System	SW00094 to SW00097	(Not used.)
Existence Of Data Trace Definition	SW00098	Bit 0 to 3 = Group 1 Definition exists = 1, No definition = 0
Data Trace Execution Status	SW00099	Bit 0 to 3 = Group 1 Trace executing = 1, Trace stopped = 0

Table 9.7 Latest Data Trace Record Number

Name	Register No.	Remarks
Data Trace Group 1	SW00100	Latest record number

■ System I/O Error Status

Name	Register No.	Remarks
I/O Error Count	SW00200	Number of I/O errors
Input Error Count	SW00201	Number of input errors
Input Error Address	SW00202	Latest input error address (For future use) (Register number of OWxxxx)
Output Error Count	SW00203	Number of output errors
Output Error Address	SW00204	Latest input error address (For future use) (Register number of OWxxxx)
Reserved by System	SW00205	(Not used.)
	SW00206	
	SW00207	

Name	Register No.	Remarks
I/O Error Status	SW00208 to SW00211	Slot 2 error status
	SW00212 to SW00215	Slot 3 error status
	to	
	SW00420 to SW00423	Slot 55 error status

■ Actions to be Taken when a Transmission Error Occurs

When a transmission error occurs during system I/O, the error status is reported in the system register as shown below.

Name	Register Number	Remarks
Slot 2 Error Status	SW00208 to SW00211	
Slot 3 Error Status	SW00212 to SW00215	LIO
Slot 6 Error Status	SW00224 to SW00227	MECHATROLINK/DeviceNet Communications error status
Slot 55 Error Status	SW00420 to SW00423	

1. LIO Station Error Status

Slot 3

Bit No.	F	3	2	1	0	
DI SW00212	Not used.	Not used.	Not used.	Not used.	Error
DO SW00213	Not used.		Not used.		Error (fuse blown)
AI SW00214	Not used.		Not used.		SVA error
AO SW00215	Not used.			SUM check-sum error	Data not adjusted

2. MECHATROLINK Station Error Status

Slot 6

Bit No.	F	E	D	9	8	1	0
SW00224	Not used.	ST#14	ST#13		ST#1	Not used.
							Error flag
SW00225	Not used.					Not used.
SW00226	Not used.				Not used.	
SW00227	Not used.					Not used.

■ System Operation Error Status

Table 9.8 System Operation Error Code Status - 1

Name	Register No.	Remarks
Error Count	SW00600	Reported when an operation error occurs in the system program.
Error Code	SW00601	
Error A Register	SW00602	
	SW00603	
Modification A Register	SW00604	
	SW00605	
Error F Register	SW00606	
	SW00607	
Modification F Register	SW00608	
	SW00609	
Error IP	SW00610	
Error CS	SW00611	
Error DWG No.	SW00612	
Function Calling DWG Type	SW00613	
Function Calling DWG Step No.	SW00614	
Reserved by System	SW00615	(Not used.)

Table 9.9 System Operation Error Code Status - 2

	Error Code	Error Contents	System Default
Integer Operation	0001H	Integer operation - underflow	-32768
	0002H	Integer operation - overflow	+32767
	0003H	Integer operation - division error	0

■ Interrupt Status

Table 9.10 Interrupt Status

Name	Register No.	Remarks
Interrupt count	SW00698	Number of interrupts detected
Modules where interrupt occurred	SW00699	Number of Modules interrupted for 1 interrupt
Interrupt Module	SW00700	Interrupt module 1
	SW00701	
	SW00702	Reserved by system
	SW00703	
	to	
	SW00798	Reserved by system
	SW00799	

Interrupt Module Details

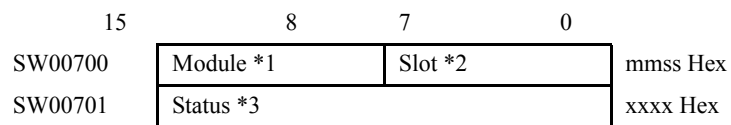

* 1. Module

mm=01H to 05H: Reserved by system.
 mm=06H: MP940/LIO is set to 06.
 mm=07H: MP940 counter (PI) is set to 07 Hex.

* 2. Slot

ss = Slot address of interrupted Module.
 MP940/LIO is slot 3, so address is 03 Hex.
 MP940/counter is slot 5, so address is 05 Hex.

* 3. Causes of Interrupts

xxxx=01H MP940/LIO DI interrupt is always 1 channel.
 MP940/counter interrupt is always 1.

9.3 Motion Errors

This section describes the details and remedies for errors that occur in motion functions.

9.3.1 Description of Motion Errors

Motion errors in the MP940 are classified as alarms detected in motion programs and axis alarms detected in SERVOPACK units.

The failure location can be determined and appropriate corrections can be taken simply by checking the contents of the alarm output register set from the Define Group Screen for motion program alarms and the contents of monitor parameter: Alarms (ILxx22) for axis alarms.

9.3.2 Processing Flow When a Motion Error Occurs

■ Troubleshooting Flow

The following illustration shows the troubleshooting flow when a motion error occurs.

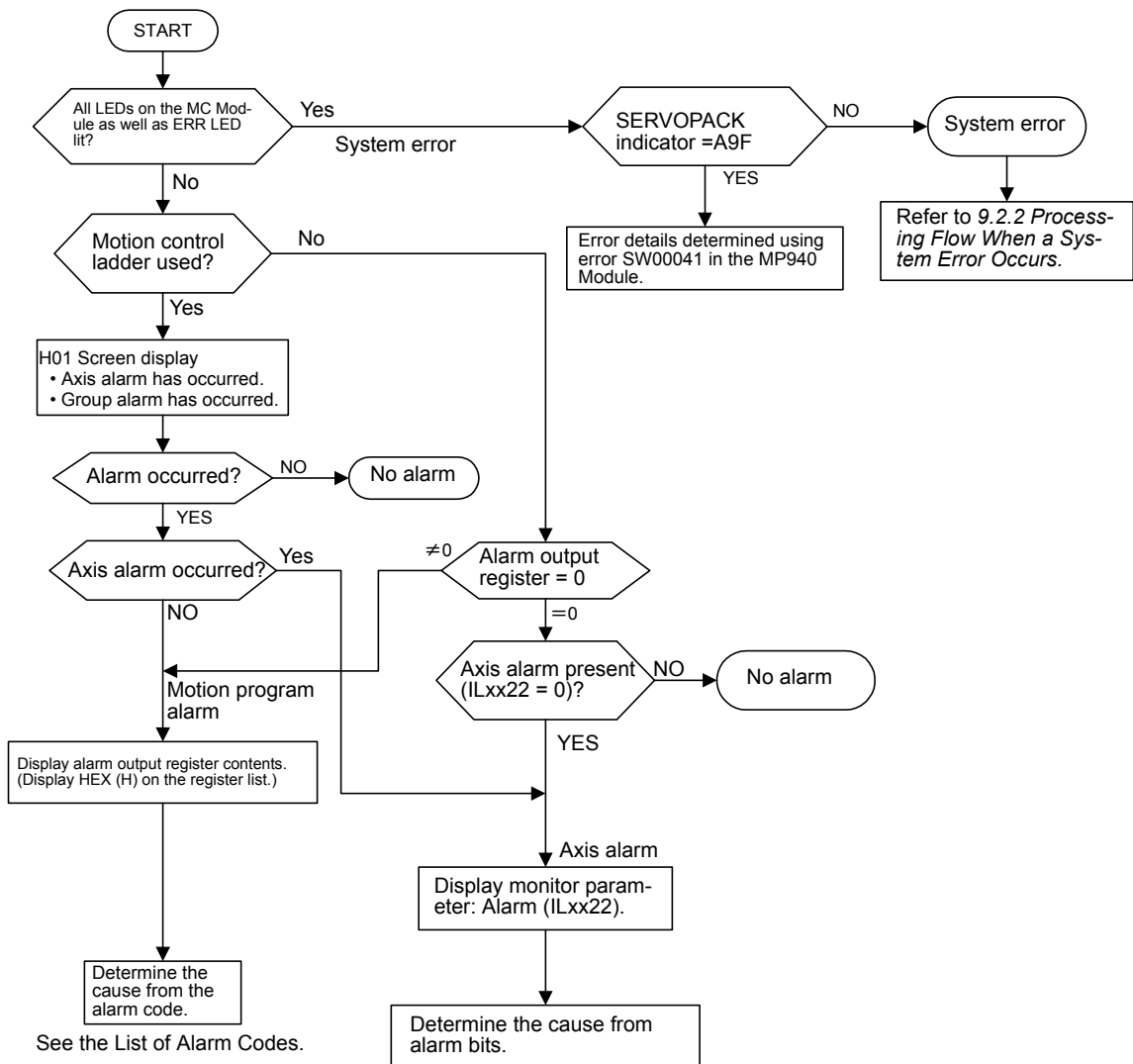

■ Motion Alarm Configuration

The following illustration shows the motion alarm configuration stored in the alarm output register.

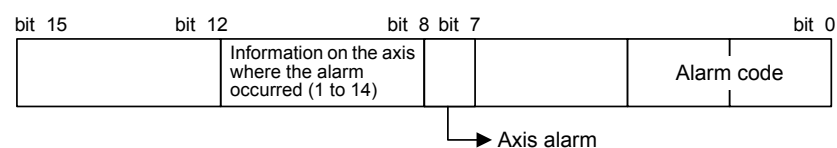

■ List of Motion Program Alarm Codes

The following table lists the List of Motion Program Alarm Codes. Use HEX(H) for the Display Mode when displaying the register list.

	Alarm Code	Contents	Remedy
Program Alarm	0	No alarm	Check the alarm details on the instructions of the motion program that was being run when an alarm occurred.
	1		
	2	Division-by-zero error	
	3		
	4		
	10h		
	11h	Exceeded the interpolation feed speed	
	12h	No interpolation feed speed specified	
	13h	Out of range after changing acceleration and deceleration parameters	
	14h		
	15h		
	16h		
	17h	Exceeded the specified axis	
	18h	Exceeded the specified number of turns	
	19h		
	1Ah		
	1Bh	Emergency stop reference executing	
	1Ch	Linear interpolation block distance traveled exceeds LONG_MAX	
	1Dh	FMX not defined	
	1Eh	Address T outside the range	
1Fh	Address P outside the range		
20h	REG data error		
Axis Alarm*	80h	Logic-control axis use prohibited	Check the alarm details on the instructions of the motion program that was being run when an alarm occurred.
	81h	Value exceeding POSMAX specified at Infinite Length Mode Axis specification.	
	82h	Distance the axis traveled exceeds LONG_MAX	
	83h	Illegal control mode	
	84h	Duplicate motion commands	
	85h	Duplicate motion command response	
	86h	Illegal motion command mode	
	87h	Outside the VEL data range setting	
	88h	Outside the INP data range setting	
	89h	Outside the ACC/SCC/DCC data range setting	
	8Ah	T reference "0" at MVT command	
	8Bh	Impossible instruction commanded, depending on Motion Module type	

* Axis numbers are stored in bits 8 to 11 when an axis alarm occurs.

■ Motion Parameter: Alarm ILxx22 Details

The following tables lists the axis alarm flags (ILxx22).

Parameter No.	Contents	Counter-measures
b0 : SVERROR	SERVOPACK error	
b1 : OTF	Positive Overtravel • Servo Amp overtravel in the positive direction detected (P_OT signal ON)	
b2 : OTR	Negative Overtravel • Servo Amp overtravel in the negative direction detected (N_OT signal ON)	
b3 : SOTF	Positive Software Limit • Machine movement toward the positive software limit range detected	
b4 : SOTR	Negative Software Limit • Machine movement toward the negative software limit range detected	
b5 :	Not used.	
b6 : TIMEOVER	Positioning Time Exceeded • Positioning was not completed in the time set at OWxx34: Positioning Complete Check Time after distribution.	
b7 : DISTOVER	Overspeed • Segment output exceeds electronic gear limits.	
b8 :	Not used.	
b9 :	Not used.	
b10 : MODERR	Control Mode Error • A Position Control Mode motion command is used in a mode other than position control.	
b11 : ZSET_NRDY	Zero Point Not Set • When an Absolute Encoder was used, the zero point is not set and a move was executed without a set zero point.	
b12 :	Not used.	
b13 :	Not used.	
b14 :	Not used.	
b15 :	Not used.	
b16 :	Not used.	
b17 :	ABS Encoder Rotation Count Over • The number of ABS encoder rotations exceeded the range of the MP940.	
b18 :	Not used.	
b19 to b31:	Not used.	

10 SERVOPACK Inspection, Maintenance, and Troubleshooting

This chapter describes the basic inspection and maintenance to be carried out by the user. In addition, troubleshooting procedures are described for problems which cause an alarm display and for problems which result in no alarm display.

10.1 Servodrive Inspection and Maintenance	10-2
10.1.1 Servomotor Inspection	10-2
10.1.2 SERVOPACK Inspection	10-2
10.1.3 Replacing Battery for Absolute Encoder	10-3
10.2 Troubleshooting	10-5
10.2.1 Troubleshooting Problems with Alarm Displays	10-5
10.2.2 Troubleshooting Problems with No Alarm Display	10-31
10.2.3 Alarm Display Table	10-33

10.1 Servodrive Inspection and Maintenance

This section describes the basic inspections and maintenance of servomotors and SERVOPACKs and the procedures for replacing the battery for absolute encoders.

10.1.1 Servomotor Inspection

For inspection and maintenance of servomotors, follow the simple, daily inspection procedures in the following table.

The AC Servomotors are brushless. Simple, daily inspection is sufficient. The inspection and maintenance frequencies in the table are only guidelines. Increase or decrease the frequency to suit the operating conditions and environment.

IMPORTANT

During inspection and maintenance, do not disassemble the servomotor. If disassembly of the servomotor is required, contact your Yaskawa representative.

Table 10.1 Servomotor Inspections

Item	Frequency	Procedure	Comments
Vibration and Noise	Daily	Touch and listen.	Levels higher than normal?
Exterior	According to degree of contamination	Clean with cloth or compressed air.	-
Insulation Resistance Measurement	At least once a year	Disconnect SERVOPACK and test insulation resistance at 500 V. Must exceed 10 M Ω .*	Contact your Yaskawa representative if the insulation resistance is below 10 M Ω .
Replacing Oil Seal	At least once every 5000 hours	Remove servomotor from machine and replace oil seal.	Applies only to motors with oil seals.
Overhaul	At least once every 20000 hours or 5 years	Contact your Yaskawa representative.	The user should not disassemble and clean the servomotor.

* Measure across the servomotor FG and the Phase-U, Phase-V, or Phase-W power line

10.1.2 SERVOPACK Inspection

For inspection and maintenance of the SERVOPACK, follow the inspection procedures in the following table at least once every year. Other routine inspections are not required.

Table 10.2 SERVOPACK Inspections

Item	Frequency	Procedure	Comments
Clean Interior and Circuit Boards	At least once a year	Check for dust, dirt, and oil on the surfaces.	Clean with compressed air.
Loose Screws	At least once a year	Check for loose terminal block and connector screws.	Tighten any loose screws.

Item	Frequency	Procedure	Comments
Defective Parts in Unit or on Circuit Boards	At least once a year	Check for discoloration, damage or discontinuities due to heating.	Contact your Yaskawa representative.

■ Part Replacement Schedule

The following parts are subject to mechanical wear or deterioration over time. To avoid failure, replace these parts at the frequency indicated.

The parameters of any SERVOPACKs overhauled by Yaskawa are reset to the standard settings before shipping. Be sure to confirm that the parameters are properly set before starting operation.

Table 10.3 Periodical Part Replacement

Part	Standard Replacement Period	Replacement Method
Cooling Fan	4 to 5 years	Replace with new part.
Smoothing Capacitor	7 to 8 years	Test. Replace with new part if necessary.
Relays	—	Test. Replace if necessary.
Fuse	10 years	Replace with new part.
Aluminum Electrolytic Capacitor on Circuit Board	5 years	Test. Replace with new circuit board if necessary.

Operating Conditions:

- Ambient Temperature: Annual average of 30°C
- Load Factor: 80% max.
- Operation Rate: 20 hours/day max.

10.1.3 Replacing Battery for Absolute Encoder

If the voltage of the battery for an absolute encoder drops to approx. 2.7 V or less, an Absolute Encoder Battery Alarm (A. 83) will occur in the SERVOPACK. This alarm occurs when the SERVOPACK receives a signal from the absolute encoder when the power to the SERVOPACK is turned ON. Therefore, the SERVOPACK will not give an alarm when the battery voltage drops below the minimum voltage level while the power is being supplied to the SERVOPACK.

Refer to *Using the Battery for the SGDh SERVOPACK* in 7.2.3 *Initializing the Absolute Encoder* for the battery type recommended for absolute encoders.

Replace the battery using the following procedure if the battery voltage drops below the minimum required battery voltage.

■ Battery Replacement Procedure

1. Replace the battery while the control power to the SERVOPACK is ON.
2. After replacement, turn OFF the power to the SERVOPACK in order to clear the Absolute Encoder Battery Alarm (A. 83).
3. Turn ON the power to the SERVOPACK again and confirm that it operates properly to complete battery replacement.

IMPORTANT

The absolute encoder data will be lost when the control power to the SERVOPACK is turned OFF and when the encoder cable is disconnected from the battery. If the data is lost, refer to *7.2.3 Initializing the Absolute Encoder*.

10.2 Troubleshooting

This section describes causes and remedies for problems which cause an alarm display and for problems which result in no alarm display.

10.2.1 Troubleshooting Problems with Alarm Displays

Problems that occur in the Servodrivers are displayed on the panel operator as "A. □□" or "CPF□□". "A.- -", however, does not indicate an alarm. Refer to the following sections to identify the cause of an alarm and the action to be taken.

Contact your Yaskawa representative if the problem cannot be solved by the described procedures.

■ A.02

A.02: Parameters Breakdown

Display and Outputs

Alarm Outputs			
Alarm Code Outputs			ALM Output
ALO1	ALO2	ALO3	
OFF	OFF	OFF	OFF

Note: OFF: Output transistor is OFF (alarm state).

Status and Remedy for Alarm



	Cause	Remedy
A	Power turned OFF during parameter write. Alarm occurred at next power ON.	Replace SERVOPACK.
B	Circuit board (1PWB) defective.	Replace SERVOPACK.

■ A.03

A.03: Main Circuit Encoder Error

Display and Outputs

Alarm Outputs			
Alarm Code Outputs			ALM Output
ALO1	ALO2	ALO3	
OFF	OFF	OFF	OFF

Note: OFF: Output transistor is OFF (alarm state).

Status and Remedy for Alarm

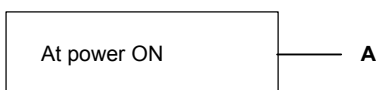

Cause		Remedy
A	Circuit board (1PWB or 2PWB) defective.	Replace SERVOPACK.

■ A.04

A.04: Parameter Setting Error

Display and Outputs

Alarm Outputs			
Alarm Code Outputs			ALM Output
ALO1	ALO2	ALO3	
OFF	OFF	OFF	OFF

Note: OFF: Output transistor is OFF (alarm state)

Status and Remedy for Alarm

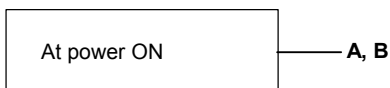

Cause		Remedy
A	An out-of-range parameter was previously set or loaded.	<ul style="list-style-type: none"> • Reset all parameters in range. • Otherwise, re-load correct parameter.
B	Circuit board (1PWB) defective.	Replace SERVOPACK.

■ A.05

A.05: Combination Error

Display and Outputs

Alarm Outputs			
Alarm Code Outputs			ALM Output
ALO1	ALO2	ALO3	
OFF	OFF	OFF	OFF

Note: OFF: Output transistor is OFF (alarm state).

Status and Remedy for Alarm



Cause		Remedy
A	The range of Servomotor capacities that can be combined has been exceeded.	Replace the servomotor so that a suitable combination is achieved.
B	Encoder parameters have not been written properly.	Replace the servomotor.

■ A.10

A.10: Overcurrent or Heat Sink Overheated

Display and Outputs

Alarm Outputs			
Alarm Code Outputs			ALM Output
ALO1	ALO2	ALO3	
ON	OFF	OFF	OFF

Note: OFF: Output transistor is OFF (alarm state).

ON: Output transistor is ON.

Status and Remedy for Alarm

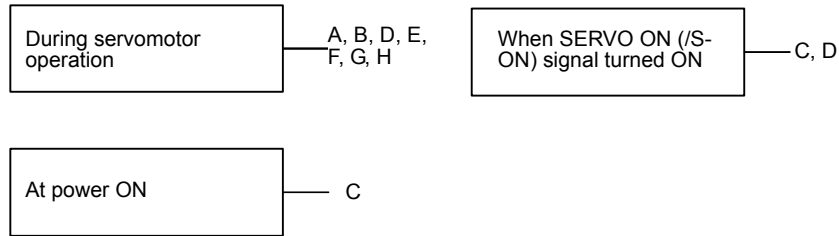

Cause		Remedy
A	Wiring shorted between SERVOPACK and servomotor.	Check and correct wiring.
B	Servomotor phase U, V, or W shorted.	Replace servomotor.
C	<ul style="list-style-type: none"> • Circuit board (1PWB) defective. • Power transistor defective. 	Replace SERVOPACK.
D	Current feedback circuit, power transistor, DB circuit, or circuit board defective.	Replace SERVOPACK.
E	The ambient temperature of the SERVOPACK exceeded 55°C.	Alter conditions so that the ambient temperature goes below 55°C.
F	The air flow around the heat sink is bad.	Follow the installation method and provide sufficient space as specified.
G	Fan stopped.	Replace SERVOPACK.
H	SERVOPACK is operating under an overload.	Reduce load.

Note: E to H can occur with a SERVOPACK with a capacity of 1.5 kW to 3 kW.

■ A.30

A.30: Regenerative Error Detected

Display and Outputs

Alarm Outputs			
Alarm Code Outputs			ALM Output
ALO1	ALO2	ALO3	
ON	ON	OFF	OFF

Note: OFF: Output transistor is OFF (alarm state).
ON: Output transistor is ON.

Status and Remedy for Alarm

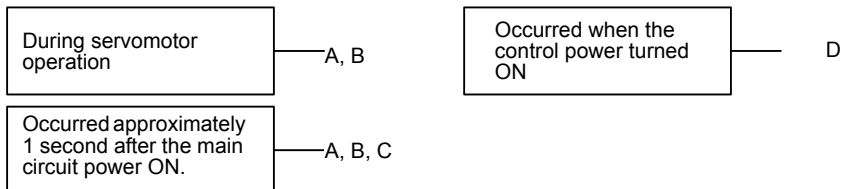

Cause		Remedy
A	Regenerative transistor is abnormal.	Replace SERVOPACK.
B	Disconnection of the regenerative resistor.	Replace SERVOPACK or regenerative resistor.
C	Regenerative Unit disconnected (for an external regenerative resistor).	Check wiring of the external regenerative resistor.
D	SERVOPACK defective.	Replace SERVOPACK.

■ A.32

A.32: Regenerative Overload

Display and Outputs

Alarm Outputs			
Alarm Code Outputs			ALM Output
ALO1	ALO2	ALO3	
ON	ON	OFF	OFF

Note: OFF: Output transistor is OFF (alarm state).

ON: Output transistor is ON.

Status and Remedy for Alarm

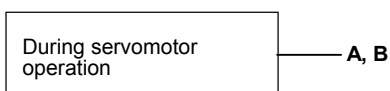

Cause		Remedy
A	Regenerative power exceeds the allowable value.	Use an external regenerative resistor that matches the regenerative power capacity.
B	Alarm occurs although an external regenerative resistor is used and the temperature rise of the regenerative resistor is small.	Correct parameter Pn600.

■ A.40

A.40: Main Circuit DC Voltage Error Detected: Overvoltage

Display and Outputs

Alarm Outputs			
Alarm Code Outputs			ALM Output
ALO1	ALO2	ALO3	
OFF	OFF	ON	OFF

Note: OFF: Output transistor is OFF (alarm state).

ON: Output transistor is ON.

Status and Remedy for Alarm

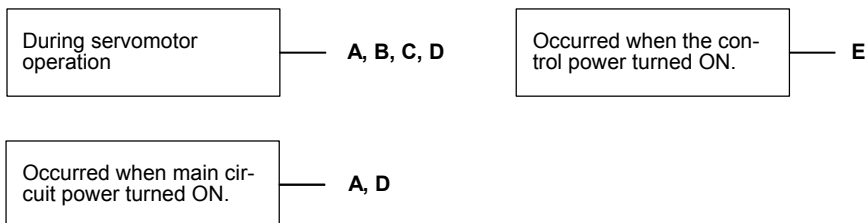

Cause		Remedy
A	The power supply voltage is not within the range of specifications.	Check power supply.
B	Load exceeds capacity of the Regenerative Unit.	Check specifications of load moment of inertia and overhanging load.
C	Regenerative transistor is abnormal.	Replace SERVOPACK.
D	Rectifying diode defective.	
E	SERVOPACK defective.	

■ A.41

A.41: Main Circuit Voltage Error Detected: Undervoltage

Display and Outputs

Alarm Outputs			
Alarm Code Outputs			ALM Output
ALO1	ALO2	ALO3	
OFF	OFF	ON	OFF

Note: OFF: Output transistor is OFF (alarm state).

ON: Output transistor is ON.

Status and Remedy for Alarm

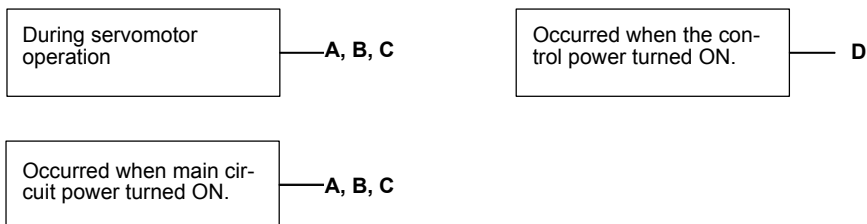

Cause		Remedy
A	The power supply voltage is not within the range of specifications.	Check power supply voltage.
B	Fuse blown.	Replace SERVOPACK.
C	Rectifying diode defective.	
D	SERVOPACK defective.	

■ A.51

A.51: Overspeed

Display and Outputs

Alarm Outputs			
Alarm Code Outputs			ALM Output
ALO1	ALO2	ALO3	
ON	OFF	ON	OFF

Note: OFF: Output transistor is OFF (alarm state).

ON: Output transistor is ON.

Status and Remedy for Alarm

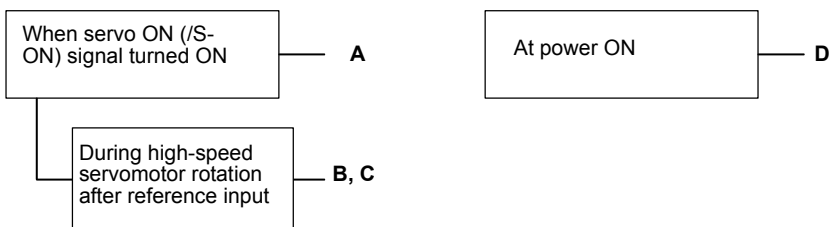

Cause		Remedy
A	Servomotor wiring incorrect.	Check and correct wiring. (Check for phase-U, -V, and -W wiring errors.)
B	Position or speed reference input is too large.	Lower the reference input values.
C	Incorrect reference input gain settings.	Check and correct parameter settings.
D	Circuit board (1PWB) defective.	Replace SERVOPACK.

■ A.71

A.71: Overload: High Load

The alarm output, status, and remedy for A.71 are the same as for A.72.

■ A.72

A.72: Overload: Low Load

Display and Outputs

Alarm Outputs			
Alarm Code Outputs			ALM Output
ALO1	ALO2	ALO3	
ON	ON	ON	OFF

Note: OFF: Output transistor is OFF (alarm state).

ON: Output transistor is ON.

Status and Remedy for Alarm

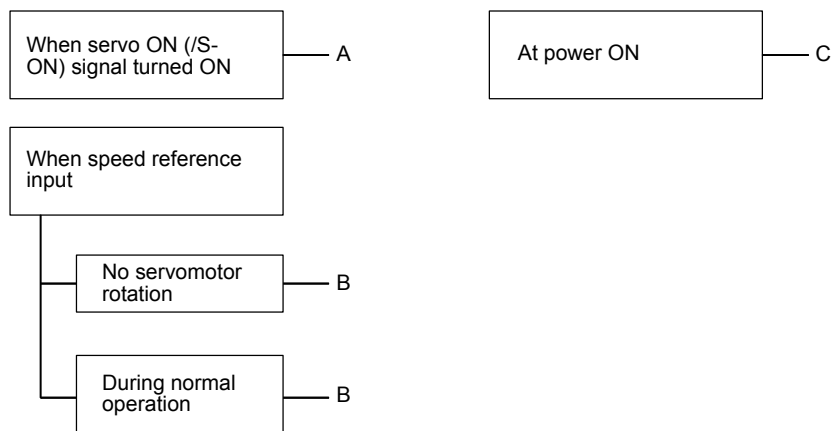

	Cause	Remedy
A	Servomotor wiring incorrect or disconnected.	Check wiring and connectors at servomotor.
B	Load greatly exceeds rated torque.	Reduce load torque and inertia. Otherwise, replace with larger capacity servomotor.
C	Circuit board (IPWB) defective.	Replace SERVOPACK.

■ A.73

A.73: Dynamic Brake Overload

Display and Outputs

Alarm Outputs			
Alarm Code Outputs			ALM Output
ALO1	ALO2	ALO3	
ON	ON	ON	OFF

Note: OFF: Output transistor is OFF (alarm state).

ON: Output transistor is ON.

Status and Remedy for Alarm

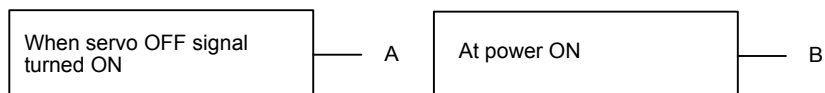

	Cause	Remedy
A	The product of the square of rotational motor speed and the combined inertia of the motor and load (rotation energy) exceeds the capacity of the dynamic brake resistor built into SERVOPACK.	<ul style="list-style-type: none"> • Lower the rotational speed. • Lower the load moment of inertia. • Minimize the use of the dynamic brake.
B	Circuit board (1PWB) defective.	Replace SERVOPACK.

■ A.74

A.74: Overload of Surge Current Limit Resistor

Display and Outputs

Alarm Outputs			
Alarm Code Outputs			ALM Output
ALO1	ALO2	ALO3	
ON	ON	ON	OFF

Note: OFF: Output transistor is OFF (alarm state).

ON: Output transistor is ON.

Status and Remedy for Alarm

When main circuit power turned ON or OFF	A	At power ON	B
Cause		Remedy	
A	Frequently turning the main circuit power ON/OFF.	Do not repeatedly turn ON/OFF the main circuit power.	
B	Circuit board (1PWB) defective.	Replace SERVOPACK.	

■ A.7A

A.7A: Heat Sink Overheated

Display and Outputs

Alarm Outputs			
Alarm Code Outputs			ALM Output
ALO1	ALO2	ALO3	
ON	ON	ON	OFF

Note: OFF: Output transistor is OFF (alarm state).

ON: Output transistor is ON.

Status and Remedy for Alarm

During servomotor operation	A, B, C, D	When control power turned ON	E
Cause		Remedy	
A	The ambient temperature of the SERVO-PACK exceeds 55°C.	Alter conditions so that the ambient temperature goes below 55°C.	
B	The air flow around the heat sink is bad.	Follow installation methods and provide sufficient space as specified.	
C	Fan stopped.	Replace SERVOPACK.	
D	SERVOPACK is operating under overload.	Reduce load.	
E	SERVOPACK defective	Replace SERVOPACK.	

Note: This alarm display tends to occur only with a SERVOPACK of 30 W to 1000 W.

■ A.81

A.81: Absolute Encoder Backup Error

Display and Outputs

Alarm Outputs			
Alarm Code Outputs			ALM Output
ALO1	ALO2	ALO3	
OFF	OFF	OFF	OFF

Note: OFF: Output transistor is OFF (alarm state).

Status and Remedy for Alarm

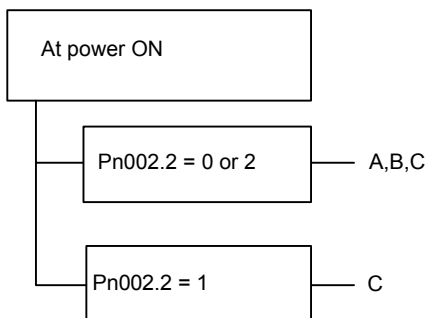

	Cause	Remedy
A	The following power supplies to the absolute encoder all failed: <ul style="list-style-type: none"> • +5 V supply • Battery power 	Follow absolute encoder set-up procedure.
B	Absolute encoder malfunctioned.	Replace servomotor.
C	Circuit board (1PWB) defective.	Replace SERVOPACK.

■ A.82

A.82: Encoder Checksum Error

Display and Outputs

Alarm Outputs			
Alarm Code Outputs			ALM Output
ALO1	ALO2	ALO3	
OFF	OFF	OFF	OFF

Note: OFF: Output transistor is OFF (alarm state).

Status and Remedy for Alarm

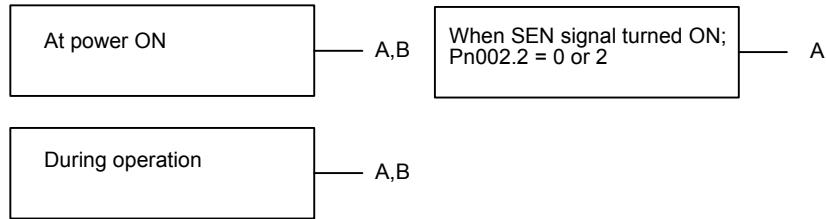

Cause		Remedy
A	Error during encoder memory check	<ul style="list-style-type: none"> Follow absolute encoder set-up procedure. Replace servomotor if error occurs frequently.
B	Circuit board (1PWB) defective.	Replace SERVOPACK.

■ A.83

A.83: Absolute Encoder Battery Error

Display and Outputs

Alarm Outputs			
Alarm Code Outputs			ALM Output
ALO1	ALO2	ALO3	
OFF	OFF	OFF	OFF

Note: OFF: Output transistor is OFF (alarm state).

Status and Remedy for Alarm

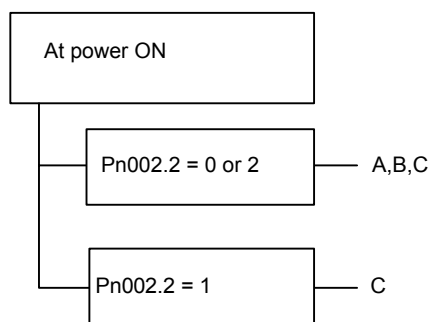

Cause		Remedy
A	<ul style="list-style-type: none"> Battery not connected Battery connection defective 	Check and correct battery connection.
B	Battery voltage below specified value. Specified value: 2.7 V.	Install a new battery while the control power to SERVOPACK is ON. After replacement, turn ON the power again.
C	Circuit board (1PWB) defective.	Replace the servomotor.

Note: No alarm will occur at the SERVOPACK if the battery error occurs during operation.

■ A.84

A.84: Absolute Encoder Data Error

Display and Outputs

Alarm Outputs			
Alarm Code Outputs			ALM Output
ALO1	ALO2	ALO3	
OFF	OFF	OFF	OFF

Note: OFF: Output transistor is OFF (alarm state).

Status and Remedy for Alarm

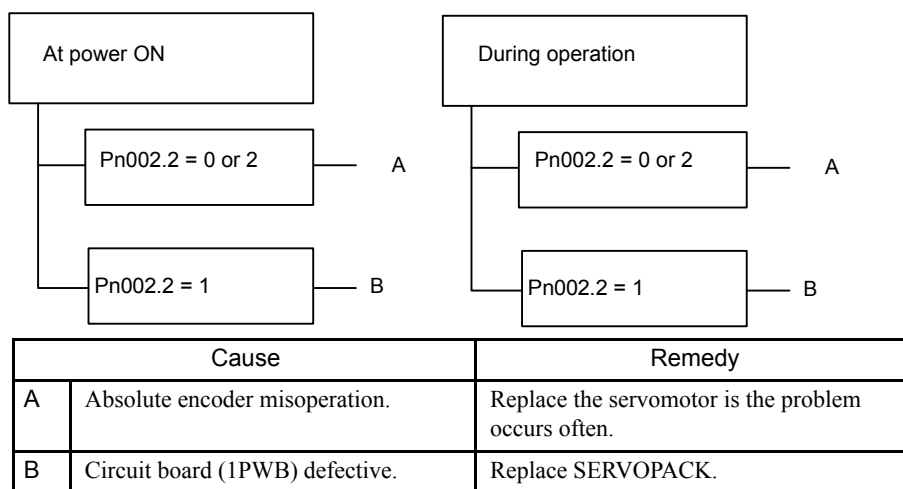

■ A.85

A.85: Absolute Encoder Overspeed

Display and Outputs

Alarm Outputs			
Alarm Code Outputs			ALM Output
ALO1	ALO2	ALO3	
OFF	OFF	OFF	OFF

Note: OFF: Output transistor is OFF (alarm state).

Status and Remedy for Alarm

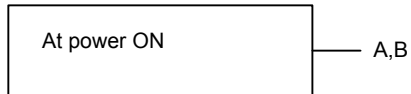

Cause		Remedy
A	Absolute encoder turned ON at a speed exceeding 200 r/min.	Turn ON power supply with the servomotor stopped.
B	Circuit board (1PWB) defective.	Replace SERVOPACK.

■ A.86

A.86: Encoder Overheated

Display and Outputs

Alarm Outputs			
Alarm Code Outputs			ALM Output
ALO1	ALO2	ALO3	
OFF	OFF	OFF	OFF

Note: OFF: Output transistor is OFF (alarm state).

Status and Remedy for Alarm

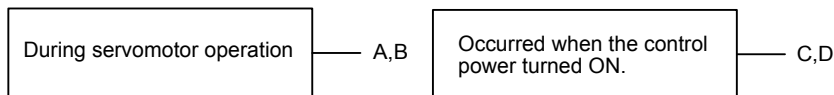

Cause		Remedy
A	The ambient temperature of the servomotor is high.	Alter conditions so that the ambient temperature goes below 40°C.
B	Servomotor is operating under overload.	Reduce load.
C	Circuit board (1PWB) defective.	Replace SERVOPACK.
D	Encoder defective.	Replace the servomotor.

■ A.9F

A.9F: MP940 Module Error

Display and Outputs

Alarm Outputs			
Alarm Code Outputs			ALM Output
ALO1	ALO2	ALO3	
ON	ON	ON	ON

Note: ON: Output transistor is ON.

Status and Remedy for Alarm

When the MP940 Power supply is turned ON.

A

Cause		Remedy
A	An error has occurred in the MP940 Module. The CPU error status (SW00041) is ON.	Check the contents of SW00041, check the details of the error, and clear the cause of the error.

Cause of Errors

If an error occurs in the MP940, the following error information will be set, and an A9F error message will be displayed on the SGDH panel.

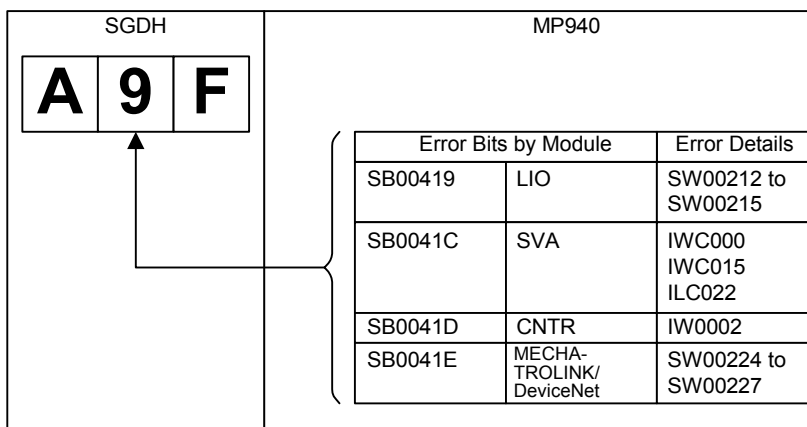

Determining Causes

If an A.9F alarm occurs, you can determine the cause of the error using the following procedure.

1. Check the error details in SW00041 (CPU status), and verify the module in which the error has occurred.
2. Check the error information for each Option Module separately.

The following table shows the details of errors.

CPU Status		Error Details																															
SB00419	LIO Error	<p>I/O Error Status (slot 3 error status)</p> <table border="1"> <tr> <td>DI</td> <td>SW00212</td> <td></td> <td></td> <td></td> </tr> <tr> <td>DO</td> <td>SW00213</td> <td></td> <td></td> <td>Error</td> </tr> <tr> <td>AI</td> <td>SW00214</td> <td></td> <td></td> <td></td> </tr> <tr> <td>AO</td> <td>SW00215</td> <td></td> <td></td> <td></td> </tr> </table> <p>Checksum Error →</p> <p>Data Unadjusted →</p> <p>Synchronous Communications Error →</p>	DI	SW00212				DO	SW00213			Error	AI	SW00214				AO	SW00215				<ul style="list-style-type: none"> • DI Error: Does not occur. • DO Fuse Error • To use SGDH AI, analog input is stopped using an SGDH synchronous communications error (with version A04 or later). • AO Adjustment Checksum Error 										
DI	SW00212																																
DO	SW00213			Error																													
AI	SW00214																																
AO	SW00215																																
SB0041C	SVA Error	<p>RUN Status (IWC000)</p> <table border="1"> <tr> <td>IBC0000</td> <td>Deviation Error</td> <td rowspan="4">IWC00F</td> </tr> <tr> <td>IBC0001</td> <td>Motion Setting Parameter Setting Error</td> </tr> <tr> <td>IBC0002</td> <td>Motion Fixed Parameter Setting Error</td> </tr> <tr> <td>IBC0003</td> <td>—</td> </tr> <tr> <td>IBC0004</td> <td>Cumulative Number of Rotations Received Error</td> <td>Number of parameter in which the out-of-range error has occurred</td> </tr> <tr> <td>IBC0155</td> <td>Command Error End Status</td> <td></td> </tr> <tr> <td>IL0022</td> <td>Alarm</td> <td></td> </tr> </table>	IBC0000	Deviation Error	IWC00F	IBC0001	Motion Setting Parameter Setting Error	IBC0002	Motion Fixed Parameter Setting Error	IBC0003	—	IBC0004	Cumulative Number of Rotations Received Error	Number of parameter in which the out-of-range error has occurred	IBC0155	Command Error End Status		IL0022	Alarm		<ul style="list-style-type: none"> • Deviation Error The position error has exceeded the set value range. • Motion Setting Parameter Setting Error The number of the parameter in which the out-of-range error has occurred is stored in IWC00F (1 to 65). • Motion Fixed Parameter Setting Error The number of the parameter in which the out-of-range error has occurred is stored in IWC00F (101 to 148). • Cumulative Number of Rotations Received Error When using an absolute encoder, the absolute position is read when the power supply is turned ON, and a receive error has occurred. • Command Error End Status Disabled when not using motion commands. • Alarm Servo error, etc. 												
IBC0000	Deviation Error	IWC00F																															
IBC0001	Motion Setting Parameter Setting Error																																
IBC0002	Motion Fixed Parameter Setting Error																																
IBC0003	—																																
IBC0004	Cumulative Number of Rotations Received Error	Number of parameter in which the out-of-range error has occurred																															
IBC0155	Command Error End Status																																
IL0022	Alarm																																
SB0041D	CNTR Error	<table border="1"> <tr> <td>IB00021</td> <td>Fixed Parameter Setting Error</td> </tr> <tr> <td></td> <td>·</td> </tr> <tr> <td></td> <td>·</td> </tr> <tr> <td></td> <td>·</td> </tr> <tr> <td>IB0002A</td> <td>A-pulse Disconnected Wire Detection</td> </tr> <tr> <td>IB0002B</td> <td>B-pulse Disconnected Wire Detection</td> </tr> </table> <p>Note: The register address used by CNTR can be changed using the lead address number (default = 0002).</p>	IB00021	Fixed Parameter Setting Error		·		·		·	IB0002A	A-pulse Disconnected Wire Detection	IB0002B	B-pulse Disconnected Wire Detection	<ul style="list-style-type: none"> • Fixed Parameter Setting Error An overflow has occurred when also using the CNTR electronic gear function in combination. • A-pulse Disconnected Wire Detected. PG wire burned out or not connected. • B-pulse Disconnected Wire Detected. PG wire burned out or not connected. 																		
IB00021	Fixed Parameter Setting Error																																
	·																																
	·																																
	·																																
IB0002A	A-pulse Disconnected Wire Detection																																
IB0002B	B-pulse Disconnected Wire Detection																																
SB0041E	Communications Option (MECHATROLINK/DeviceNet)	<p>Input Error Status (Slot 6 error status)</p> <table border="1"> <thead> <tr> <th></th> <th>F</th> <th>E</th> <th>2</th> <th>1</th> <th>0</th> </tr> </thead> <tbody> <tr> <td>SW00224</td> <td>ST#15</td> <td>ST#14</td> <td>· · · · ·</td> <td>ST#2</td> <td>ST#1</td> </tr> <tr> <td>SW00225</td> <td>ST#15</td> <td></td> <td>· · · · ·</td> <td></td> <td>ST#16</td> </tr> <tr> <td>SW00226</td> <td>ST#47</td> <td></td> <td>· · · · ·</td> <td></td> <td>ST#32</td> </tr> <tr> <td>SW00227</td> <td>ST#63</td> <td></td> <td>· · · · ·</td> <td></td> <td>ST#48</td> </tr> </tbody> </table> <p>The bit corresponding to the slot number for the error occurring on MECHATROLINK/DeviceNet is turned ON.</p>		F	E	2	1	0	SW00224	ST#15	ST#14	· · · · ·	ST#2	ST#1	SW00225	ST#15		· · · · ·		ST#16	SW00226	ST#47		· · · · ·		ST#32	SW00227	ST#63		· · · · ·		ST#48	<ul style="list-style-type: none"> • MECHATROLINK: Slot 1 to slot 14 • DeviceNet: Bits for slot 0 to slot 63 are turned ON.
	F	E	2	1	0																												
SW00224	ST#15	ST#14	· · · · ·	ST#2	ST#1																												
SW00225	ST#15		· · · · ·		ST#16																												
SW00226	ST#47		· · · · ·		ST#32																												
SW00227	ST#63		· · · · ·		ST#48																												

■ A.b1

A.b1: Reference Speed Input Read Error

Display and Outputs

Alarm Outputs			
Alarm Code Outputs			ALM Output
ALO1	ALO2	ALO3	
OFF	OFF	OFF	OFF

Note: OFF: Output transistor is OFF (alarm state).

Status and Remedy for Alarm

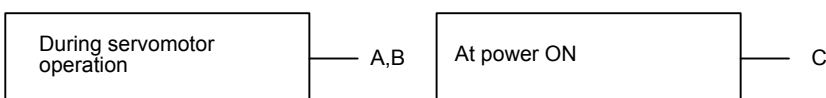

Cause		Remedy
A	Error in reference read-in unit (A/D Converter, etc.).	Reset alarm and restart operation.
B	Reference read-in unit faulty (A/D Converter, etc.).	Replace SERVOPACK.
C	Circuit board (1PWB) defective.	Replace SERVOPACK.

■ A.b2

A.b2: Reference Torque Input Read Error

Display and Outputs

Alarm Outputs			
Alarm Code Outputs			ALM Output
ALO1	ALO2	ALO3	
OFF	OFF	OFF	OFF

Note: OFF: Output transistor is OFF (alarm state).

Status and Remedy for Alarm

During servomotor operation	A,B	At power ON	C
Cause		Remedy	
A	Error in reference read-in unit (A/D Converter, etc.).	Reset alarm and restart operation.	
B	Reference read-in unit faulty (A/D Converter, etc.).	Replace SERVOPACK.	
C	Circuit board (1PWB) defective.	Replace SERVOPACK.	

■ A.C1

A.C1: Servo Overrun

Display and Outputs

Alarm Outputs			
Alarm Code Outputs			ALM Output
ALO1	ALO2	ALO3	
ON	OFF	ON	OFF

Note: OFF: Output transistor is OFF (alarm state).
ON: Output transistor is ON.

Status and Remedy for Alarm

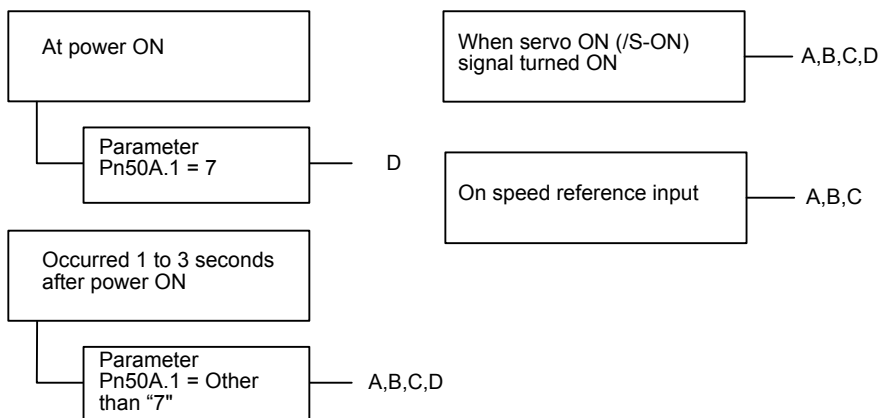

Cause		Remedy
A	Servomotor wiring incorrect or disconnected.	Check wiring and connectors at servomotor.
B	Encoder wiring incorrect or disconnected.	Check wiring and connectors at encoder.
C	Encoder defective.	Replace servomotor.
D	Circuit board (1PWB) defective.	Replace SERVOPACK.

■ A.C8

A.C8: Absolute Encoder Clear Error and Multi-turn Limit Setting Error

Display and Outputs

Alarm Outputs			
Alarm Code Outputs			ALM Output
ALO1	ALO2	ALO3	
ON	OFF	ON	OFF

Note: OFF: Output transistor is OFF (alarm state).
ON: Output transistor is ON.

Status and Remedy for Alarm

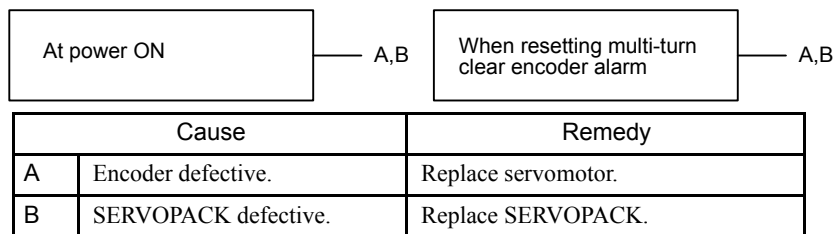

■ A.C9

A.C9: Encoder Communications Error

Display and Outputs

Alarm Outputs			
Alarm Code Outputs			ALM Output
ALO1	ALO2	ALO3	
ON	OFF	ON	OFF

Note: OFF: Output transistor is OFF (alarm state).
ON: Output transistor is ON.

Status and Remedy for Alarm

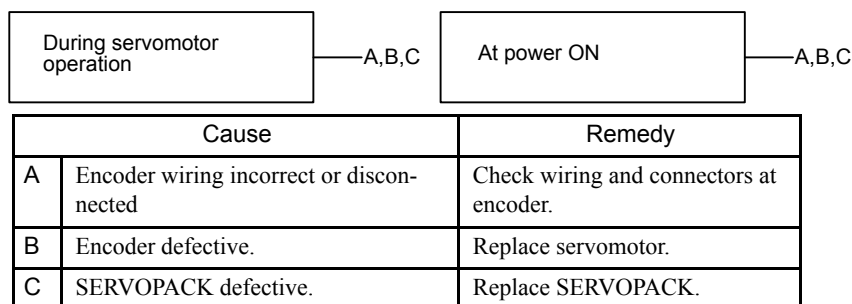

■ A.CA

A.CA: Encoder Parameter Error

Display and Outputs

Alarm Outputs			
Alarm Code Outputs			ALM Output
ALO1	ALO2	ALO3	
ON	OFF	ON	OFF

Note: OFF: Output transistor is OFF (alarm state).

ON: Output transistor is ON.

Status and Remedy for Alarm



	Cause	Remedy
A	Encoder defective.	Replace servomotor.
B	SERVOPACK defective.	Replace SERVOPACK.

■ A.Cb

A.Cb: Encoder Echoback Error

Display and Outputs

Alarm Outputs			
Alarm Code Outputs			ALM Output
ALO1	ALO2	ALO3	
ON	OFF	ON	OFF

Note: OFF: Output transistor is OFF (alarm state).

ON: Output transistor is ON.

Status and Remedy for Alarm

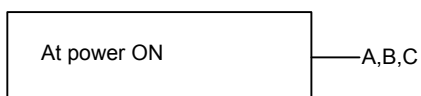

	Cause	Remedy
A	Encoder wiring incorrect or disconnected.	Check wiring and connectors at encoder.
B	Encoder defective.	Replace servomotor.
C	SERVOPACK defective.	Replace SERVOPACK.

■ A.CC

A.CC: Multi-turn Limit Disagreement Alarm

Display and Outputs

Alarm Outputs			
Alarm Code Outputs			ALM Output
ALO1	ALO2	ALO3	
ON	OFF	ON	OFF

Note: OFF: Output transistor is OFF (alarm state).

ON: Output transistor is ON.

Status and Remedy for Alarm



	Cause	Remedy
A	The setting of the Multi-turn Limit Setting (Pn205) parameter in the SERVOPACK is incorrect.	Change parameter Pn205.
B	The multi-turn limit has not been set in the encoder.	Check to be sure the Multi-turn Limit Setting (Pn205) parameter in the SERVOPACK is correct, create a Multi-turn Limit Disagreement Alarm (A.CC), and then execute the encoder multi-turn limit setting change (Fn013).

■ A.d0

A.d0: Position Error Pulse Overflow

Display and Outputs

Alarm Outputs			
Alarm Code Outputs			ALM Output
ALO1	ALO2	ALO3	
ON	ON	OFF	OFF

Note: OFF: Output transistor is OFF (alarm state).

ON: Output transistor is ON.

Status and Remedy for Alarm

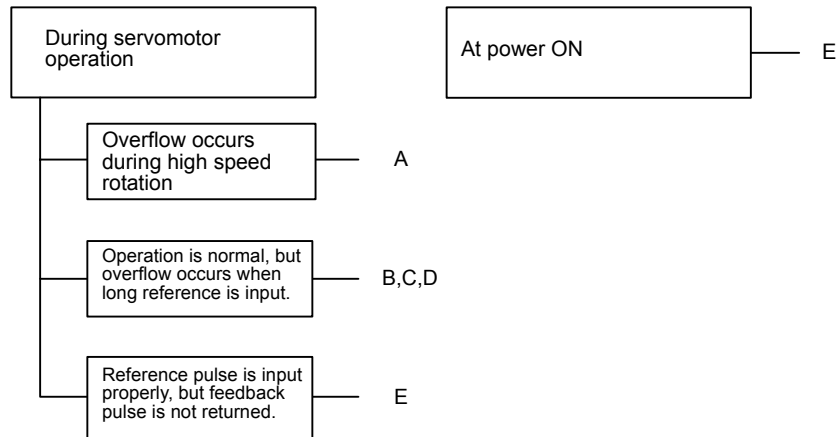

Cause		Remedy
A	Servomotor wiring incorrect or poor connection	Check wiring and connectors at encoder.
B	SERVOPACK was not correctly adjusted.	Increase speed loop gain (Pn100) and position loop gain (Pn102).
C	Motor load was excessive.	Reduce load torque or moment of inertia. If problem not corrected, replace with a motor with larger capacity.
D	Position reference pulse frequency was too high.	<ul style="list-style-type: none"> • Increase or decrease reference pulse frequency. • Add smoothing function. • Correct electronic gear ratio.
E	Circuit board (1PWB) defective.	Replace SERVOPACK.

■ A.E0

A.E0: No Response

Display and Outputs

Alarm Outputs			
Alarm Code Outputs			ALM Output
ALO1	ALO2	ALO3	
OFF	ON	ON	OFF

Note: OFF: Output transistor is OFF (alarm state).

ON: Output transistor is ON.

Status and Remedy for Alarm

At power ON	A
-------------	---

	Cause	Remedy
A	<ul style="list-style-type: none"> • No MP940 Module is mounted, or MP940 is defective. • There is no 24-VDC power supply to the MP940. • User program error 	<ul style="list-style-type: none"> • Supply a 24-VDC power supply to the MP940. • Correct the MP940 user program. • Initialize the MP940 Module's memory. • Replace the MP940 Module.

■ A.E1

A.E1: Option Timeout

Display and Outputs

Alarm Outputs			
Alarm Code Outputs			ALM Output
ALO1	ALO2	ALO3	
OFF	ON	ON	OFF

Note: OFF: Output transistor is OFF (alarm state).

ON: Output transistor is ON.

Status and Remedy for Alarm

At power ON	A
-------------	---

	Cause	Remedy
A	Option Unit is defective.	Replace the Option Unit.

■ A.E2

A.E2: Option WDC Error

Display and Outputs

Alarm Outputs			
Alarm Code Outputs			ALM Output
ALO1	ALO2	ALO3	
OFF	ON	ON	OFF

Note: OFF: Output transistor is OFF (alarm state).

ON: Output transistor is ON.

Status and Remedy for Alarm

At power ON		A
Cause		Remedy
A	Option Unit is defective.	Replace the Option Unit.

■ A.F1

A.F1: Power Line Open Phase

Display and Outputs

Alarm Outputs			
Alarm Code Outputs			ALM Output
ALO1	ALO2	ALO3	
OFF	ON	OFF	OFF

Note: OFF: Output transistor is OFF (alarm state).
ON: Output transistor is ON.

Status and Remedy for Alarm

At main circuit power supply ON.		A,B	Occurred when the control power turned ON.		C
Cause		Remedy			
A	One phase (L1, L2, or L3) of the main circuit power supply is disconnected.	<ul style="list-style-type: none"> • Check power supply. • Check wiring of the main circuit power supply. • Check MCCB, noise filter, magnetic contactor. 			
B	There is one phase where the line voltage is low.	Check power supply.			
C	SERVOPACK defective.	Replace SERVOPACK.			

Note: A and B tend to occur in a SERVOPACK with a capacity of 500 W or higher.

■ CPF00

CPF00: Digital Operator Transmission Error 1

This alarm is not stored in the alarm trace-back function memory.

Display and Outputs

Alarm Outputs			
Alarm Code Outputs			ALM Output
ALO1	ALO2	ALO3	
Not specified			

Status and Remedy for Alarm

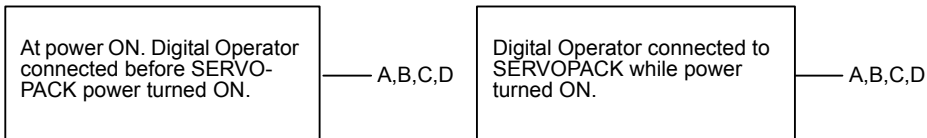

Cause		Remedy
A	Cable defective or poor contact between Digital Operator and SERVOPACK.	<ul style="list-style-type: none"> • Check connector connections. • Replace cable.
B	Malfunction due to external noise.	Separate Digital Operator and cable from noise source.
C	Digital Operator defective.	Replace Digital Operator.
D	SERVOPACK defective.	Replace SERVOPACK.

■ CPF01

CPF01: Digital Operator Transmission Error 2

This alarm is not stored in the alarm trace-back function memory.

Display and Outputs

Alarm Outputs			
Alarm Code Outputs			ALM Output
ALO1	ALO2	ALO3	
Not specified			

Status and Remedy for Alarm

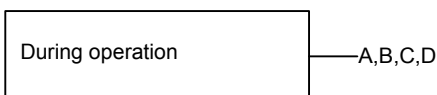

Cause		Remedy
A	Cable defective or poor contact between Digital Operator and SERVOPACK.	<ul style="list-style-type: none"> • Check connector connections. • Replace cable.
B	Malfunction due to external noise	Separate Digital Operator and cable from noise source.
C	Digital Operator defective.	Replace Digital Operator.
D	SERVOPACK defective.	Replace SERVOPACK.

■ A. --

A.- -: Normal Operation

This is not an alarm display.

Display and Outputs

Alarm Outputs			
Alarm Code Outputs			ALM Output
ALO1	ALO2	ALO3	
OFF	OFF	OFF	ON

Note: OFF: Output transistor is OFF (alarm state).

ON: Output transistor is ON.

10.2.2 Troubleshooting Problems with No Alarm Display

Refer to the tables below to identify the cause of a problem which causes no alarm display and take the remedy described.

Turn OFF the servo system power supply before commencing the shaded procedures.

Contact your Yaskawa representative if the problem cannot be solved by the described procedures.

Table 10.4 Troubleshooting Table No Alarm Display

Symptom	Cause	Inspection	Remedy
Servomotor Does Not Start	Power not connected	Check voltage between power supply terminals.	Correct the power circuit.
	Loose connection	Check terminals of connectors (CN1, CN2).	Tighten any loose parts.
	Connector (CN1) external wiring incorrect	Check connector (CN1) external wiring	Refer to connection diagram and correct wiring.
	Servomotor or encoder wiring disconnected.		Reconnect wiring
	Overloaded	Run under no load.	Reduce load or replace with larger capacity servomotor.
	Speed/position references not input	Check reference input pins.	Correctly input speed/position references.
	/S-ON is turned OFF	Check settings of parameters Pn50A.0 and Pn50A.1.	Turn /S-ON input ON.
	/P-CON input function setting incorrect	Check parameter Pn000.1.	Refer to 6.4.2 <i>Function Selection Constants</i> and set parameters to match application.
	Reference pulse mode selection incorrect.	Refer to 6.4.4 <i>Position-related Parameters</i> for parameter Pn200.0	Correct setting of parameter Pn200.0.
	Encoder type differs from parameter setting.	Incremental or absolute encoder?	Set parameter Pn002.2 to the encoder type being used.
	P-OT and N-OT inputs are turned OFF.		Turn P-OT and N-OT input signals ON.
	CLR input is turned ON	Check status of error counter clear input.	Turn CLR input OFF.
SEN input is turned OFF.	When absolute encoder is used.	Turn SEN input ON.	
Servomotor Moves Instantaneously, then Stops	Servomotor or encoder wiring incorrect.		Refer to 5.4 <i>Connecting Peripheral Devices</i> , 5.5 <i>SERVOPACK Main Circuit Connection</i> , and 5.6 <i>SERVOPACK I/O Signals</i> and correct wiring.
Suddenly Stops during Operation and will Not Restart	Alarm reset signal (/ALM-RST) is turned ON because an alarm occurred.		Remove cause of alarm. Turn alarm reset signal (ALM-RST) from ON to OFF.
Servomotor Speed Unstable	Wiring connection to motor defective	Check connection of power lead (phases U, V, and W) and encoder connectors.	Tighten any loose terminals or connectors.

Symptom	Cause	Inspection	Remedy
Servomotor Vibrates at Approximately 200 to 400 Hz.	Speed loop gain value too high.		Reduce speed loop gain (Pn100) preset value.
	Speed/position reference input lead too long.		Minimize length of speed/position reference input lead, with impedance not exceeding several hundred ohms
	Speed/position reference input lead is bundled with power cables.		Separate reference input lead at least 30 cm from power cables.
High Rotation Speed Overshoot on Starting and Stopping.	Speed loop gain value too high.		Reduce speed loop gain (Pn100) preset value. Increase integration time constant (Pn101).
Servomotor Overheated	Ambient temperature too high	Measure servomotor ambient temperature.	Reduce ambient temperature to 40°C max.
	Servomotor surface dirty	Visual check	Clean dust and oil from motor surface.
	Overload	Perform operation with no load.	Lighten the load, or replace with greater capacity motor.
Abnormal Noise	Mechanical mounting incorrect	Servomotor mounting screws loose?	Tighten mounting screws.
		Coupling not centered?	Center coupling.
		Coupling unbalanced?	Balance coupling.
	Bearing defective	Check noise and vibration near bearing.	Consult your Yaskawa representative if defective.
Machine causing vibrations	Foreign object intrusion, damage or deformation of sliding parts of machine.	Consult with machine manufacturer.	
Speed Reference 0 V but Servomotor Rotates.	Speed reference voltage offset applied		Adjust reference offset.

10.2.3 Alarm Display Table

A summary of alarm displays and alarm code outputs is given in the following table.

Table 10.5 Alarm Display Table

Alarm Display	Alarm Code Outputs			ALM Output	Alarm Name	Meaning
	ALO1	ALO2	ALO3			
A.02	OFF	OFF	OFF	OFF	Parameter Breakdown ^{*2}	EEPROM data of SERVOPACK is abnormal.
A.03					Main Circuit Encoder Error	Detection data for power circuit is abnormal.
A.04					Parameter Setting Error ^{*2}	The parameter setting is outside the allowable setting range.
A.05					Combination Error	SERVOPACK and servomotor capacities do not match each other.
A.10	ON	OFF	OFF	OFF	Overcurrent or Heat Sink Overheated ^{*2}	An overcurrent flowed through the IGBT. Heat sink of SERVOPACK was overheated.
A.30	ON	ON	OFF	OFF	Regeneration Error Detected	<ul style="list-style-type: none"> Regenerative circuit is faulty Regenerative resistor is faulty.
A.32					Regenerative Overload	Regenerative energy exceeds regenerative resistor capacity.
A.40	OFF	OFF	ON	OFF	Overvoltage	Main circuit DC voltage is excessively high
A.41					Undervoltage	Main circuit DC voltage is excessively low.
A.51	ON	OFF	ON	OFF	Overspeed	Motor speed is abnormally high.
A.71	ON	ON	ON	OFF	Overload: High Load	The motor was operating for several seconds to several tens of seconds under a torque largely exceeding ratings.
A.72					Overload: Low Load	The motor was operating continuously under a torque largely exceeding ratings.
A.73					Dynamic Brake Overload	When the dynamic brake was applied, rotational energy exceeded the capacity of dynamic brake resistor.
A.74					Overload of Surge Current Limit Resistor	The main circuit power was frequently turned ON and OFF.
A.7A					Heat Sink Overheated ^{*1}	The heat sink of SERVOPACK overheated.

10.2.3 Alarm Display Table

Alarm Display	Alarm Code Outputs			ALM Output	Alarm Name	Meaning
	ALO1	ALO2	ALO3			
A.81	OFF	OFF	OFF	OFF	Encoder Backup Error ^{*2}	All the power supplies for the absolute encoder have failed and position data was cleared.
A.82					Encoder Checksum Error ^{*2}	The checksum results of encoder memory is abnormal.
A.83					Absolute Encoder Battery Error	Battery voltage for the absolute encoder has dropped.
A.84					Encoder absolute alarm ^{*1}	Absolute data received has an error.
A.85					Encoder Overspeed	The encoder was rotating at high speed when the power was turned ON.
A.86	OFF	OFF	OFF	OFF	Encoder Overheated	The internal temperature of encoder is too high.
A.9F					Option Warning	Warning has occurred in the option (MP940).
A.b1					Reference Speed Input Read Error	The A/D converter for reference speed input is faulty.
A.b2					Reference Torque Input Read Error	The A/D converter for reference torque input is faulty.
A.bF					System Alarm ^{*2}	
A.C1	ON	OFF	ON	OFF	Servo Overrun Detected	The servomotor ran out of control.
A.C8					Absolute Encoder Clear Error and Multi-turn Limit Setting Error	The multi-turn for the absolute encoder was not properly cleared or set.
A.C9					Encoder Communications Error ^{*2}	Communications between SERVOPACK and encoder is not possible.
A.CA					Encoder Parameter Error ^{*2}	Encoder parameters are faulty.
A.Cb					Encoder Echoback Error ^{*2}	Contents of communications with encoder is incorrect.
ACC					Multi-turn Limit Disagreement ^{*3}	Different multi-turn limits have been set in the encoder and SERVOPACK.
A.d0	ON	ON	OFF	OFF	Position Error Pulse Overflow	Position error pulse exceeded parameter (Pn505).
A.E0	OFF	ON	ON	OFF	No Option Unit	No MP940 Option Unit is mounted.
A.E1					Option Timeout	No response from the option board.
A.E2					Option WDC error	MP940 Option WDC error.
A.F1	OFF	ON	OFF	OFF	Power Line Open Phase	One phase is not connected in the main power supply
CPF00	Not specified				Digital Operator Transmission Error	Digital Operator (JUSP-OP02A-2) fails to communicate with SERVOPACK.
CPF01						
A. - -	OFF	OFF	OFF	ON	Not an error	Normal operation status

- * 1. This alarm display appears only within the range of 30 W to 1000 W.
- * 2. These alarms are not reset for the alarm reset signal (/ALM-RST).
Eliminate the cause of the alarm and then turn OFF the power supply to reset the alarms.
- * 3. This alarm will occur for the new version (SGDM-□DA) only.

Note: OFF: Output transistor is OFF (high).

ON: Output transistor is ON (low).

11 Motion Control

This chapter gives an overview of motion control and describes the motion commands.

11.1 Overview of Motion Control	11-2
11.1.1 Motion Control for the MP940-	11-2
11.1.2 Motion Control Methods-	11-2
11.1.3 Examples of Motion Control Applications-	11-5
11.2 Control Modes	11-7
11.2.1 Overview of Control Modes	11-7
11.2.2 Speed Control Mode	11-7
11.2.3 Torque Control Mode-	11-12
11.2.4 Phase Control Mode	11-15
11.2.5 Zero Point Return Mode	11-23
11.3 Position Control	11-28
11.3.1 Prerequisites for Position Control	11-28
11.3.2 Precautions in Changing to Position Control Mode	11-43
11.3.3 Position Control without Using Motion Commands	11-47
11.4 Position Control Using Motion Commands	11-50
11.4.1 Overview of Motion Commands	11-50
11.4.2 Positioning (POSING)	11-52
11.4.3 External Positioning (EX_POSING)	11-58
11.4.4 Zero Point Return (ZRET)	11-61
11.4.5 Interpolation (INTERPOLATE)	11-73
11.4.6 Interpolation with Position Detection (LATCH)	11-74
11.4.7 Fixed Speed Feed (FEED)-	11-75
11.4.8 Fixed Length Feed (STEP)	11-78
11.4.9 Zero Point Setting (ZSET)	11-81

11.1 Overview of Motion Control

This section describes the methods used for motion control and gives some examples of their use.

11.1.1 Motion Control for the MP940

The MP940 Machine Controller provides fully integrated sequence control and motion control.

Connected to the SGDH-□□AE SERVOPACK via the shared memory bus, the MP940 one-axis controller achieves not only simple positioning, but also high-speed and highly accurate synchronous control.

The following figure shows a conceptual diagram of the MP940 system.

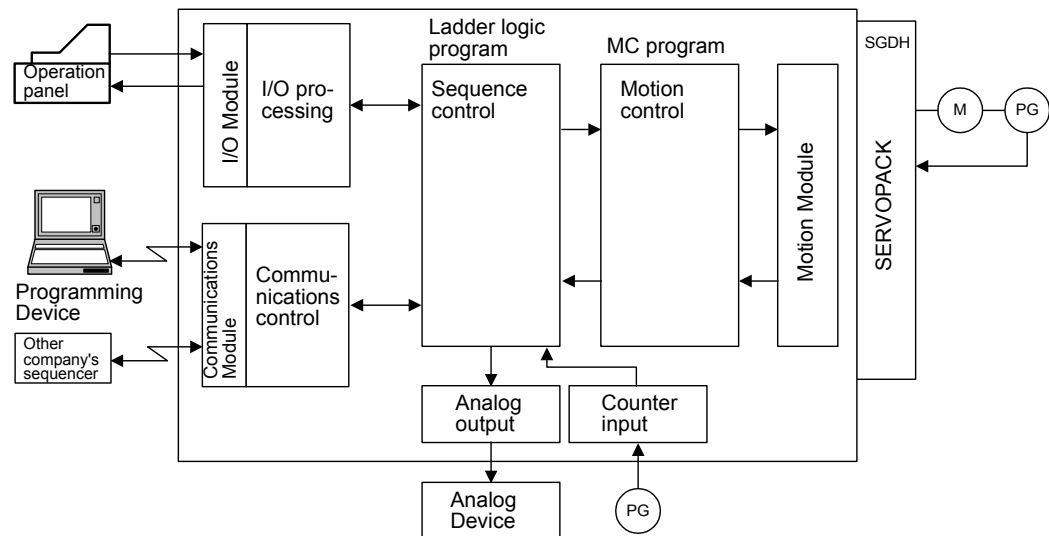

11.1.2 Motion Control Methods

By using MP940 Modules, motions for a wide variety of applications can be controlled. There are two programming methods for controlling motions: Ladder logic programs and motion programs.

An overview of each programming method is given below.

■ Ladder Logic Programming

Ladder logic programs are designed mainly for sequence control. The setting parameters and monitor parameters used as interfaces with the Motion Modules are directly written to and read by the ladder logic programs to perform motion control.

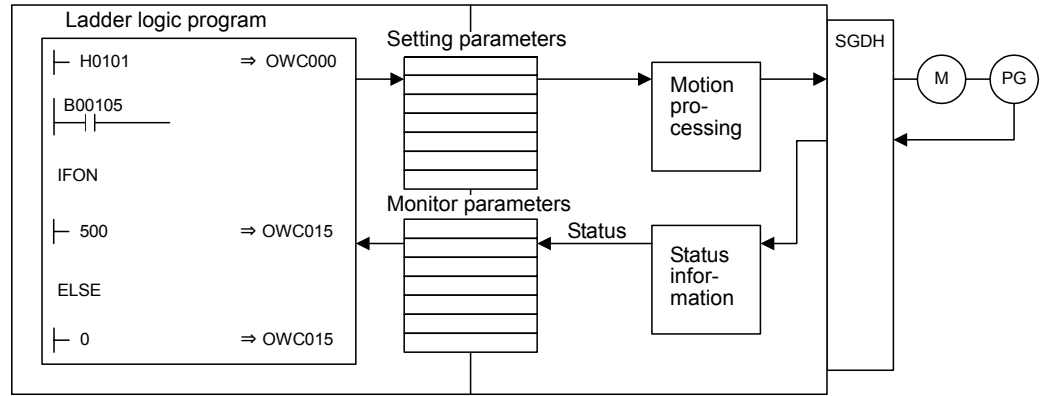

Special operations can be programmed and combined as user functions.

For details, refer to *Chapter 6 Parameters* and descriptions on parameters given for each Motion Module.

■ Motion Programming

The motion programs that have been created perform motion control using a special motion language. Up to 32 programs can be created, and these can also be executed in parallel.

The system performs command completion checks and other overhead processes.

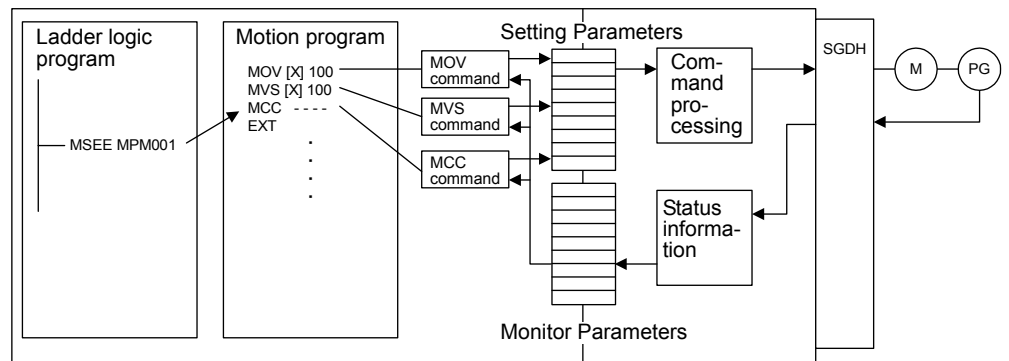

The use of the special motion language enables complex operations to be easily programmed. The special motion commands shown in the following table are provided as standard in the MP9□□ Series.

Com- mands	<p>Axis move commands: 6 types MOV, MVS, ZRN, SKP, MVT, EXM</p> <p>Basic control commands: 6 types ABS, INC, POS, PLN, MVM, PLD</p> <p>Speed and acceleration/deceleration commands: 7 types ACC, DCC, SCC, VEL, IAC, IDC, IFP, FMX</p> <p>High-level control commands: 4 types PFN, INP, SNG, UFC</p> <p>Control commands: 10 types MSEE, TIM, IOW, END, RET, EOX, IF ELSE IEND, WHILE WEND, PFORK JOINTO PJOINT, SFORK JOINTO SJOINT</p> <p>Math and sequence control commands: 32 types =, +, -, *, /, MOD, , ^, &, !, (), S{ }, R{ }, SIN, COS, TAN, ASN, ACS, ATN, SQRT, BIN, BCD, =, <>, >, <, >=, <=, SFR, SFL, BLK, CLR</p>
---------------	--

11.1.3 Examples of Motion Control Applications

The following illustrations show application examples of the MP940.

■ Application Example 1: Labelling Unit

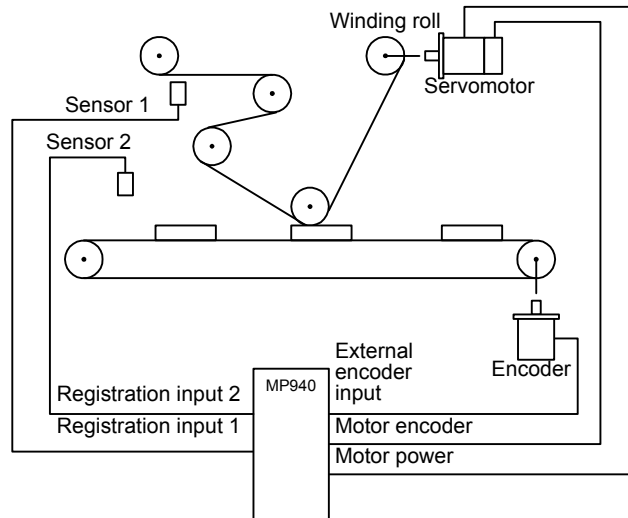

■ Application Example 2: Alignment Unit

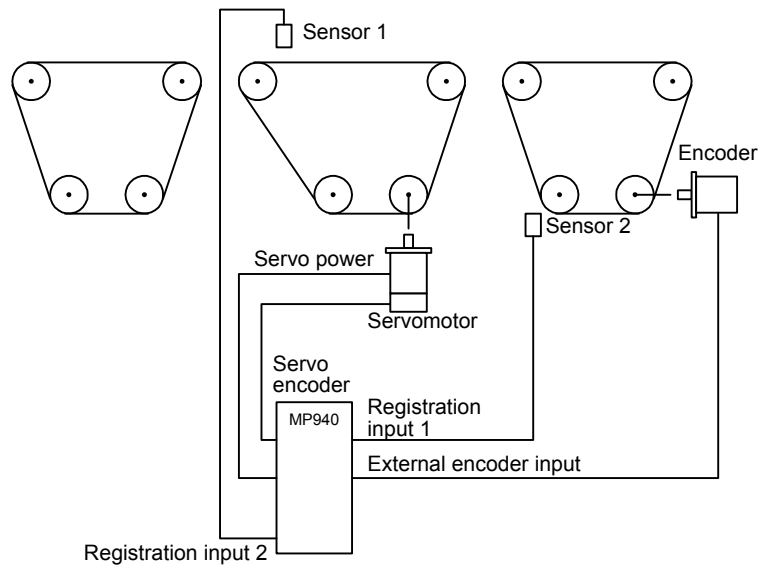

■ Application Example 3: Cut-to-length Unit

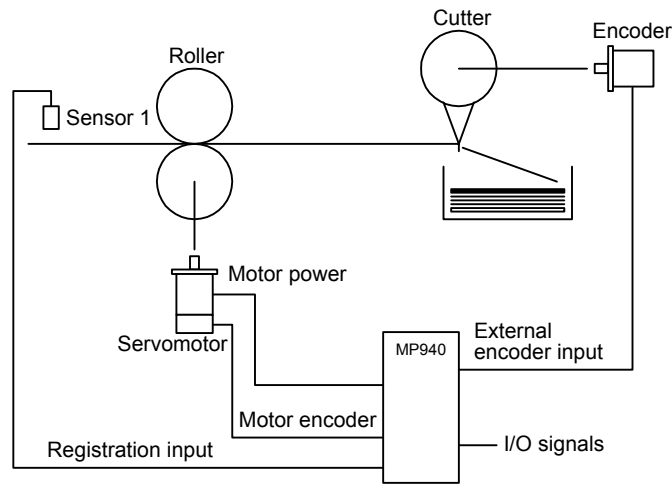

■ Application Example 4: Conveyor Follow-up Processor

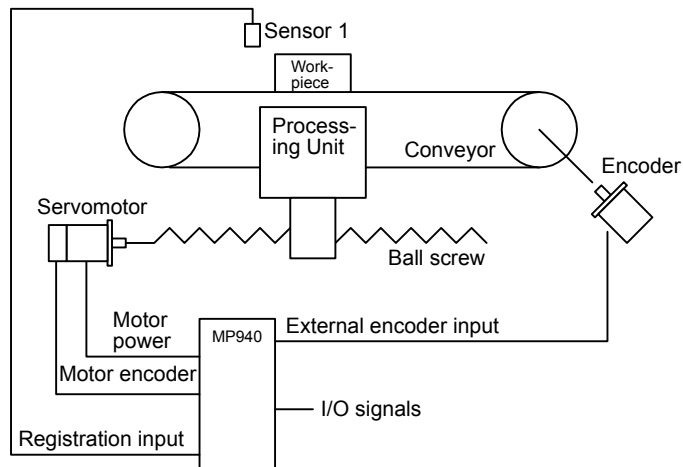

11.2 Control Modes

This section describes the motion control modes that can be used by the MP940.

11.2.1 Overview of Control Modes

Five control modes are available for MP940 Motion Modules. These modes can be switched in real time, according to the purpose.

The following table shows the control mode that can be used by MP940 Motion Modules, and gives an overview and some examples of their uses.

Control Mode	Overview	Typical Applications
Speed Control Mode	Rotates the motor at the specified speed.	Conveyors or main axes
Torque Control Mode	Outputs the specified torque.	Injection molding machines or presses
Position Control Mode*	Specifies the target position and speed. Executes a position loop, identifies the difference to the target position from the encoder, converts the difference to the speed reference, and performs position control.	Conveyors or XY tables
Phase Control Mode	While executing speed control using a standard speed reference, generates the target position from the speed reference, and performs phase control.	Electronic cams or electronic shafts
Zero Point Return Mode*	Performs zero point positioning when an incremental encoder is used.	

- * There are two methods for returning to the zero point:
- Using ZERO POINT RETURN command for position control
 - Using Zero Point Return Mode

11.2.2 Speed Control Mode

■ Overview

This mode is used to rotate the motor at the desired speed.

A speed reference is output to the servodrive according to the specified speed reference, linear acceleration/deceleration time constant, and filter time constant.

The acceleration/deceleration time can be set as desired.

S-curve acceleration/deceleration can be easily performed by the user program (one command).

The Speed Control Mode can also be used for a general-purpose D/A converter. In this case, set the linear acceleration/deceleration time constant and the filter time constant to “0.”

■ Details

Use the following procedure to perform operation in the Speed Control Mode.

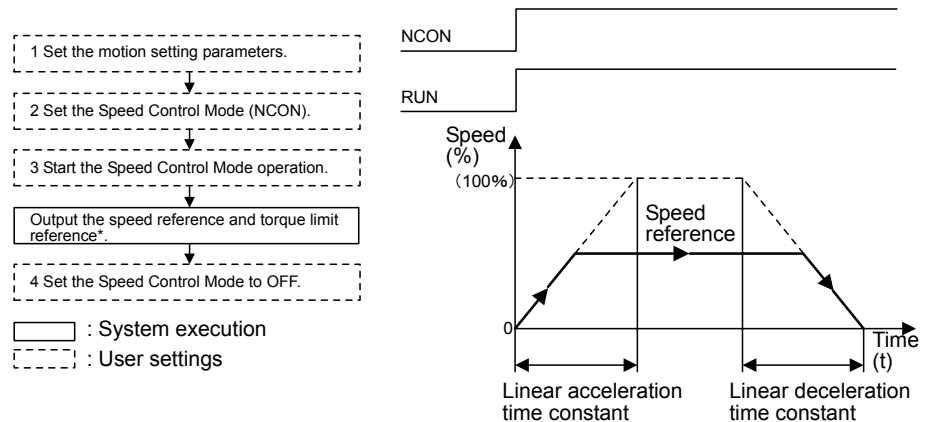

IMPORTANT

When the power is turned ON, the MP940 connected to the SERVOPACK with a bus automatically reads SERVOPACK parameters, such as the encoder pulse and the number of feedback pulses per one motor rotation, which used to be set in the Controller as fixed parameters.

Therefore, the following parameters are not included in the fixed motion parameters of the MP940.

- Encoder selection
- Rotation direction selection when using an absolute encoder
- Rated speed (except for the one used in the simulation mode)
- Number of feedback pulses per one motor rotation (except for the one used in the simulation mode)
- Maximum speed of absolute encoder

The following parameter is fixed with the MP940.

- Pulse counting method selection: Always A/B method \times 4 multiplication.

1. Set the motion parameters to be used in the Speed Control Mode.

The following three methods can be used to set the setting parameters.

- Using the CP-717 Setting Parameter Screen
- Using a ladder logic program
- Using a motion program

Table 11.1 Examples of Setting Parameters

Name	Register No.	Setting Range	Meaning	Setting Example
Positive Torque Limit Setting (TLIMP)	OWC002	-327.68 to 327.67	0.01 = 0.01% 1 = 1%	-100.00 (-100.00%)
Positive Speed Limiter Setting (NLIMP)	OWC004	0.00 to 327.67	0.01 = 0.01% 1 = 1%	130.00 (130.00%)
Negative Speed Limiter Setting (NLIMN)	OWC005	0.00 to 327.67	0.01 = 0.01% 1 = 1%	130.00 (130.00%)
Linear Acceleration Time Constant (NACC)	OWC00C	0 to 32767	Linear acceleration time constant (ms) at speed pattern generation	1000 (1 second)
Linear Deceleration Time Constant (NDEC)	OWC00D	0 to 32767	Linear deceleration time constant (ms) at speed pattern generation	1000 (1 second)
Filter Time Constant Setting (NNUM)	OWC014	0 to 255	For simple S-curve acceleration	0
Speed Reference Setting (NREF)	OWC015	-327.68 to 327.67	Speed reference value 0.01 = 0.01% 1 = 1%	50.00 (50.00%)

2. Select the Speed Control Mode (NCON) (bit 0 of OWC000).
3. Set the Servo ON (RUN) to ON (bit 0 of OWC001).

The speed reference will be output for the axis according to the specified motion parameters.

Even while the Speed Control Mode is being selected, the motion parameter settings can be changed.

4. To stop operation, set the RUN command (RUN) and the Speed Control Mode (NCON) to OFF.

■ User Program Examples

Example of RUN Operation

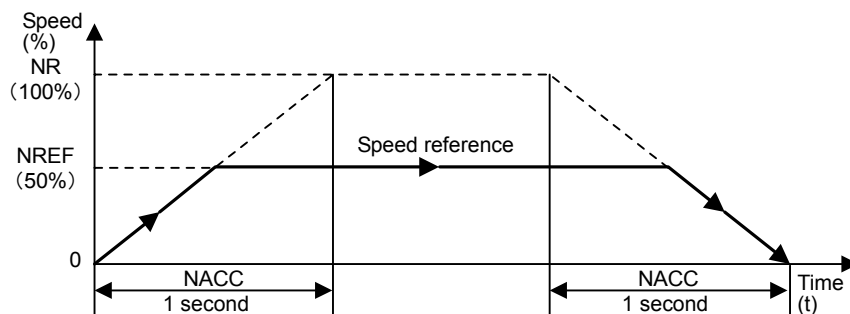

Fig 11.1 Speed Pattern

Ladder Logic Program Example

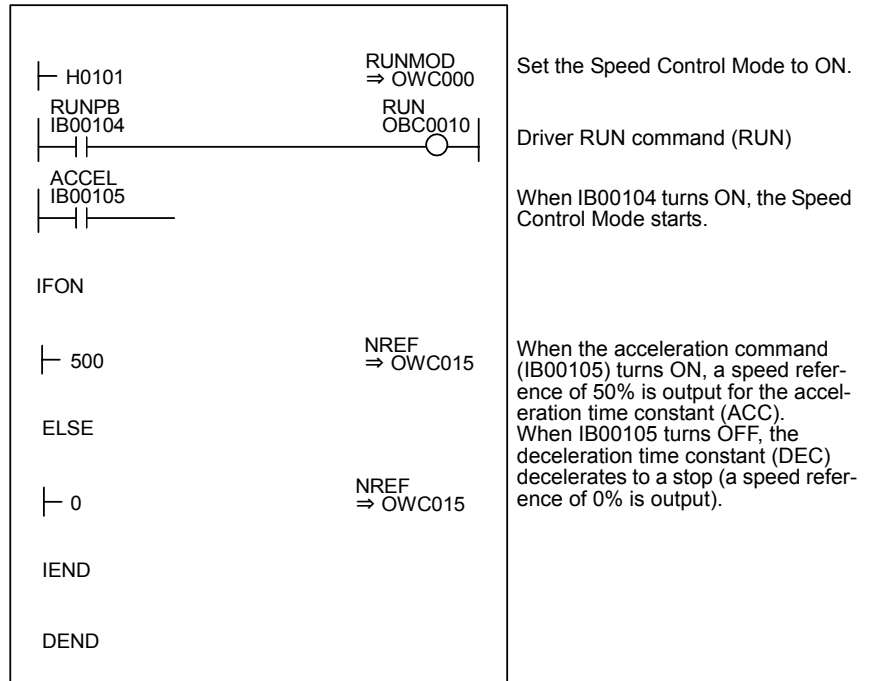

Fig 11.2 RUN Commands (DWG H01)

The example in the above illustration has been greatly simplified. In actual operation, each register can be controlled from the user program.

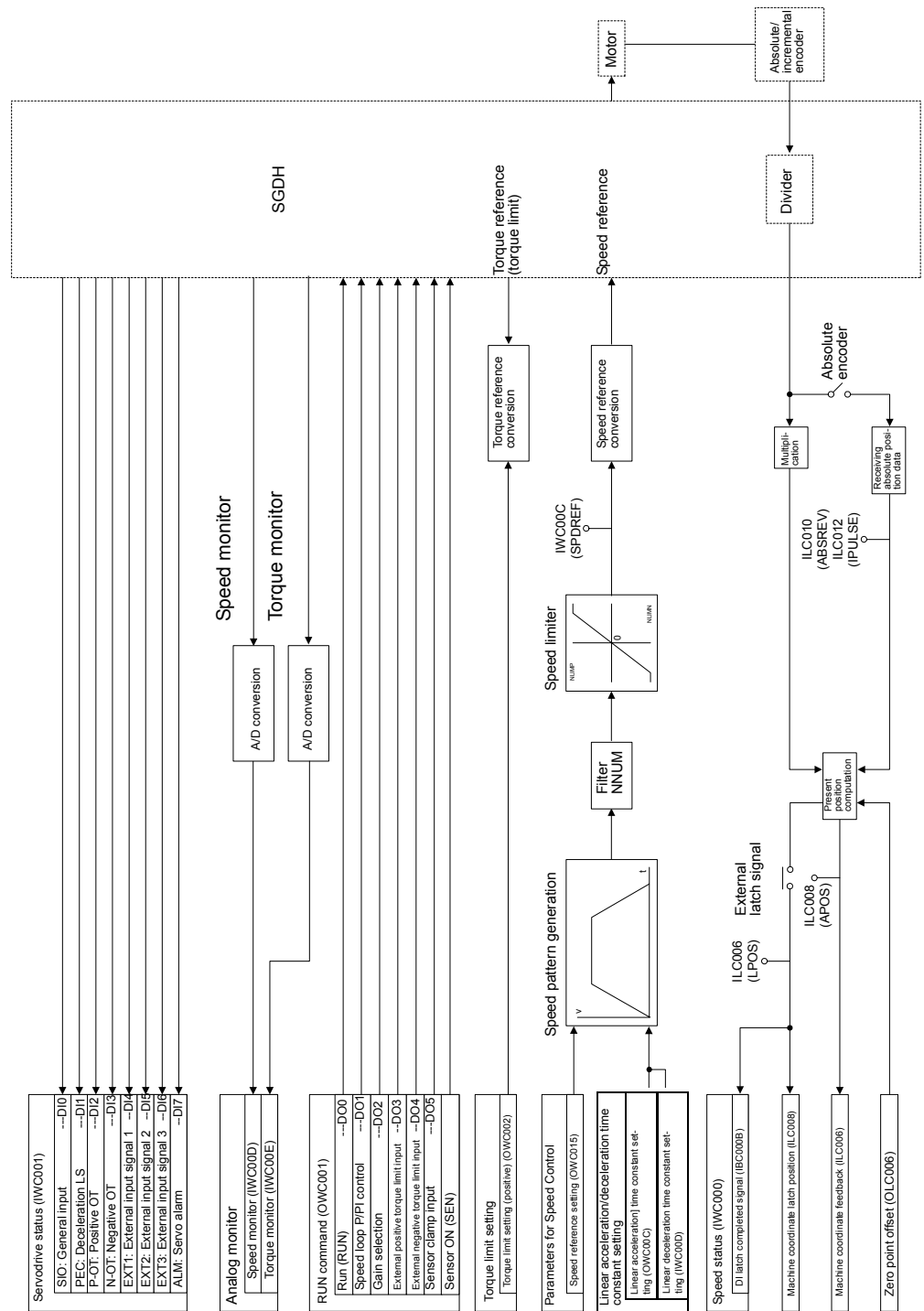

Fig 11.3 MP940 SVA Speed Control Mode Block Diagram

11.2.3 Torque Control Mode

■ Overview

This mode is used to generate a constant torque, regardless of the speed.

Select this mode to keep the metal mold of a plastic molding machine, such as an injection molding machine, at a constant pressure.

When the Torque Control Mode is selected, the specified torque reference and speed limit reference are output by the servodrive.

■ Details

Use the following procedure to perform operations in the Torque Control Mode.

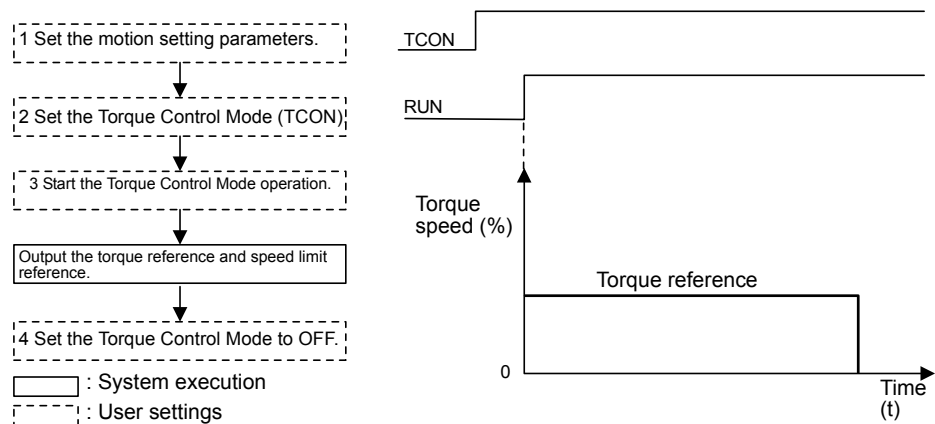

1. Set the motion parameters to be used in the Torque Control Mode.

Table 11.2 Examples of Setting Parameters

Name	Register No.	Meaning	Setting Example
Torque Reference Setting (TREF)	OWC01B	Sets the torque reference value at 0.01%.	50.00 (50.00%)
Speed Limit Setting (NLIM)	OWC01C	Sets the speed limit value at 0.01%.	50.00 (50%)

2. Select the Torque Control Mode (TCON) (bit 1 of OWC000).
3. Set the Servo ON (RUN) to ON (bit 0 of OWC001).

The torque reference and the speed limit reference will be output for the axis according to the specified motion parameters.

Even while the Torque Control Mode is being selected, the motion parameter settings can be changed.

4. To stop operation, set the RUN command (RUN) and the Torque Control Mode (TCON) to OFF.

■ User Program Example

Example of RUN Operation

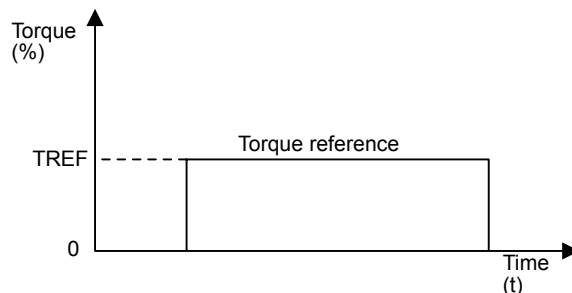

Fig 11.4 Torque Pattern

Ladder Logic Program Example

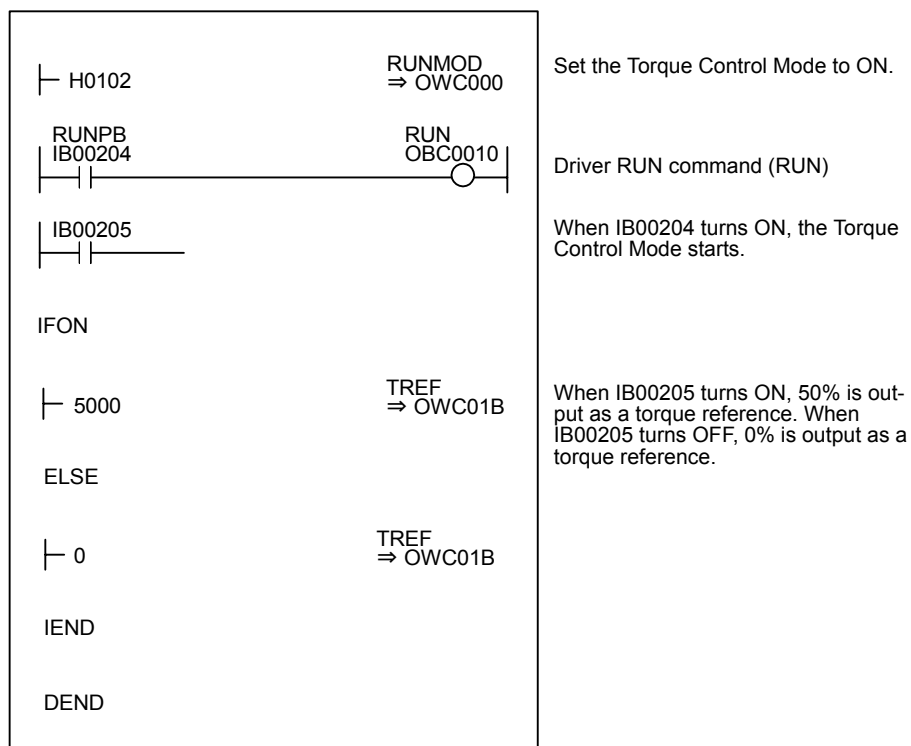

Fig 11.5 RUN Commands (DWG H02)

The example in the above illustration has been greatly simplified. In actual operation, each register can be controlled from the user program.

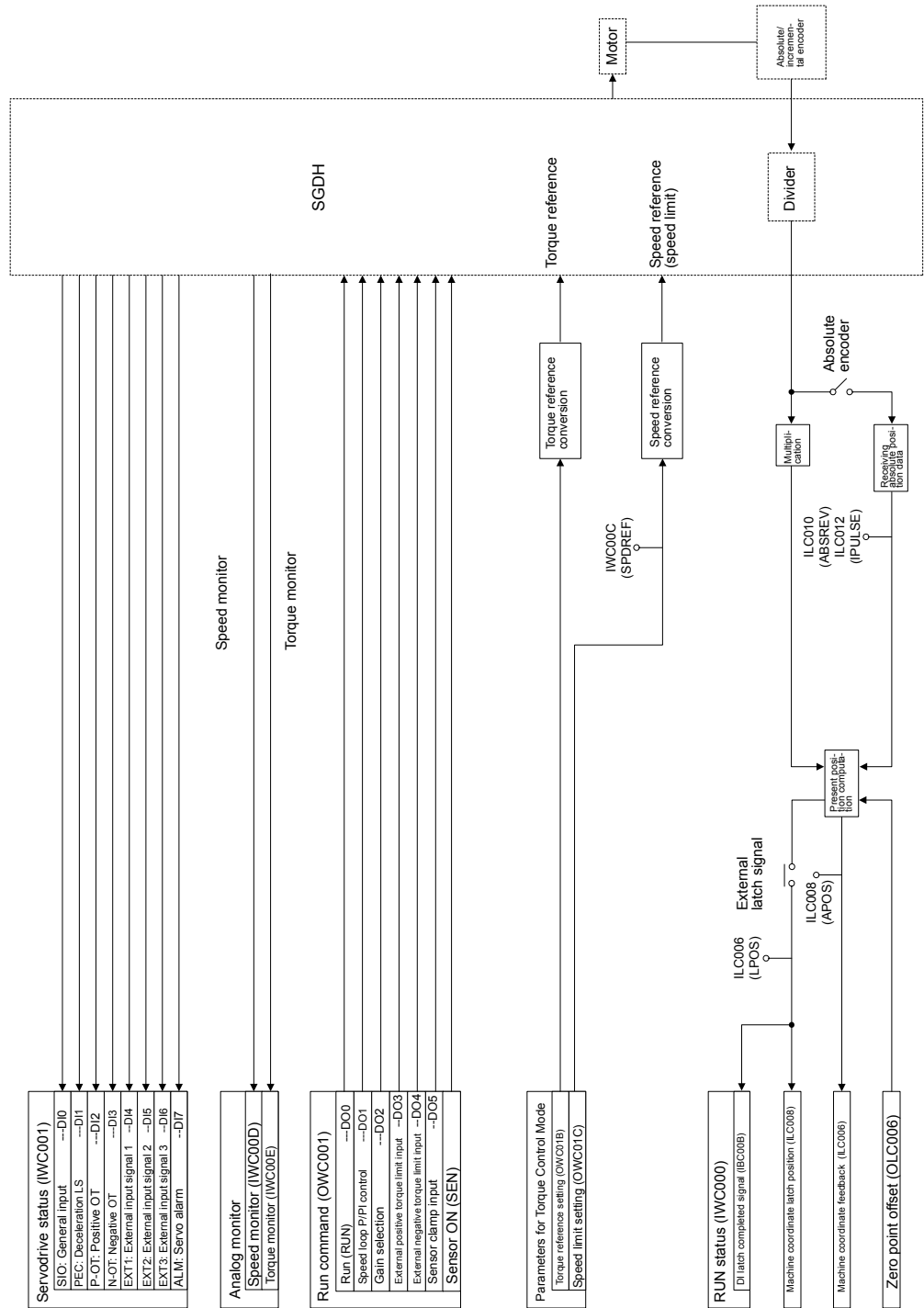

Fig 11.6 MP940 SVA Torque Control Mode Block Diagram

11.2.4 Phase Control Mode

Overview

This mode is used to rotate the motor according to the specified speed reference, and at the same time to strictly control the number of rotations.

Electronic shafts and electronic cams can thus be used in the servomotors of complex machine configurations. Phase alignment and synchronous operation, as well as ratio operation and cam variable speed operation have all been replaced by software.

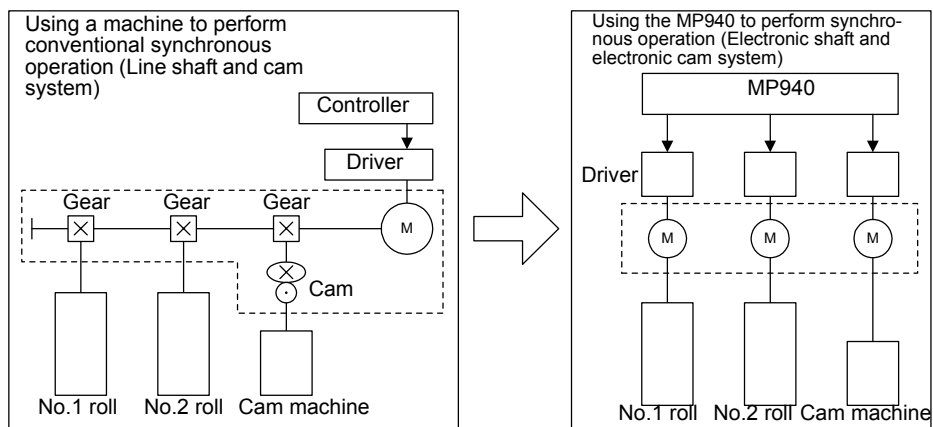
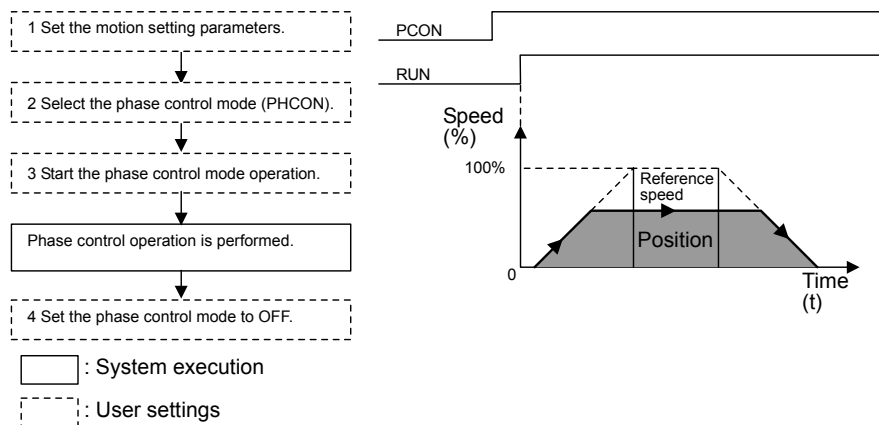

Fig 11.7 Electronic Cam and Electronic Shaft Illustration

Details

Use the following procedure to perform phase control operation.



1. Set the motion parameters. Use the user program to control the reference speed so that no shock occurs.

The following three methods can be used to set the setting parameters.

- Using the CP-717 Setting Parameter Screen
- Using a ladder logic program
- Using a motion program

The following table shows the related parameters when the phase control mode is used.

Table 11.3 Examples of Setting Parameters

Name	Register No.	Setting Range	Meaning	Electronic Shaft Setting Example	Electronic Cam Setting Example
Positive Torque Limit Setting (TLIMP)	OWC002	-327.68 to 327.67	0.01 = 0.01% 1 = 1%	-100.00 (-100.00%)	-100.00 (-100.00%)
Positive Speed Limiter Setting (NLIMP)	OWC004	0.00 to 327.67	0.01 = 0.01% 1 = 1%	130.00 (130.00%)	130.00 (130.00%)
Negative Speed Limiter Setting (NLIMN)	OWC005	0.00 to 327.67	0.01 = 0.01% 1 = 1%	130.00 (130.00%)	130.00 (130.00%)
Error Count Alarm Detection Setting (EOV)	OWC00F	0 to 65535	1 = 1 pulse	65535	65535
Speed Reference Setting (NREF)	OWC015	-327.68 to 327.67	0.01 = 0.01% 1 = 1%	50.00 (50.00%)	Set by the ladder logic program
Phase Bias Setting (PHBIAS)	OLC016	-2^{31} to $2^{31}-1$	1 = 1 pulse	Set by the ladder logic program	Set by the ladder logic program
Speed Compensation Setting (NCOM)	OWC018	-327.68 to 327.67	0.01 = 0.01% 1 = 1%	0.00	0.00
Proportional Gain Setting (PGAIN)	OWC019	0.0 to 3276.7	0.1 = 0.1 /s 1 = 1 /s	1.5 (1.5)	250.0 (250.0)
Integral Time Setting (TI)	OWC01A	0 to 32767	1 = 1 ms	300 (300 ms)	0 (0 ms)

2. Select the Phase Control Mode (PHCON) (bit 3 of OWC000).

At this time, also set Phase Reference Disable (PHREFOFF: bit 7 of OWC000). Normally, this bit is set to OFF for electronic shaft applications, and it is set to ON for electronic cam applications.

3. Set the Servo ON (RUN) to ON (bit 0 of OWC001).

Phase control will be performed for the axis according to the specified motion parameters.

Even while phase control is being performed, the motion parameter settings can be changed.

4. To stop operation, set the RUN command (RUN) and the phase control mode (PHCON) to OFF.

■ User Program Example 1: Electronic Shaft

Example of RUN Operation

Phase control can be called “speed control with position compensation” or “position control with 100% speed feed forward.” “Position” means the motor angle of rotation, and is therefore called “phase control.” An electronic shaft can be configured using this phase control.

The following figure shows a block diagram of a phase control loop.

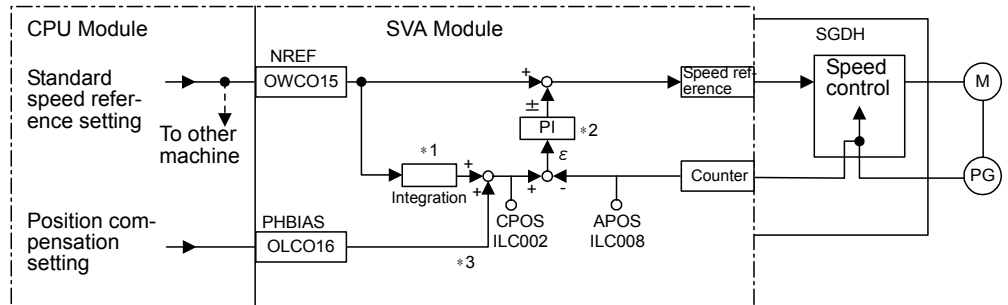

- * 1. Integrates the reference speed reference, and calculates the corresponding position (pulse).
- * 2. Generates the speed reference from the target position (CPOS) and current position (APOS) error ϵ . This is the position (phase) compensation.
- * 3. To move the phase, the distance to be moved (the angle of rotation of the motor axis converted to the number of pulses) can be added as the phase compensation setting.

Fig 11.8 Block Diagram of Phase Control Loop

The rotational phase of the motor can be managed (controlled) using the above method.

This control loop is processed in the SVA Module. Therefore, the user can easily control the electronic shaft simply by selecting the phase control mode on the CPU Module and providing the required parameters for the SVA Module.

Ladder Logic Program Example

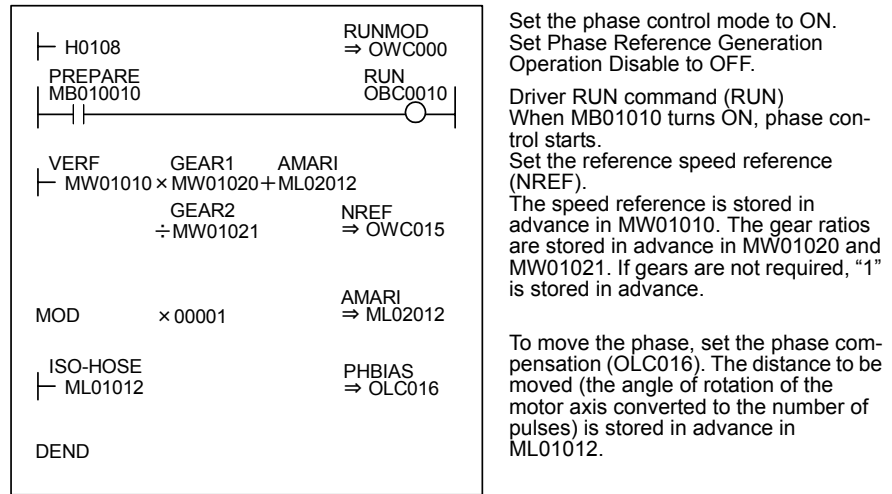

Fig 11.9 RUN Commands (DWG H04)

The example in the illustration on the previous page has been greatly simplified. In actual operation, each register can be controlled from the user program.

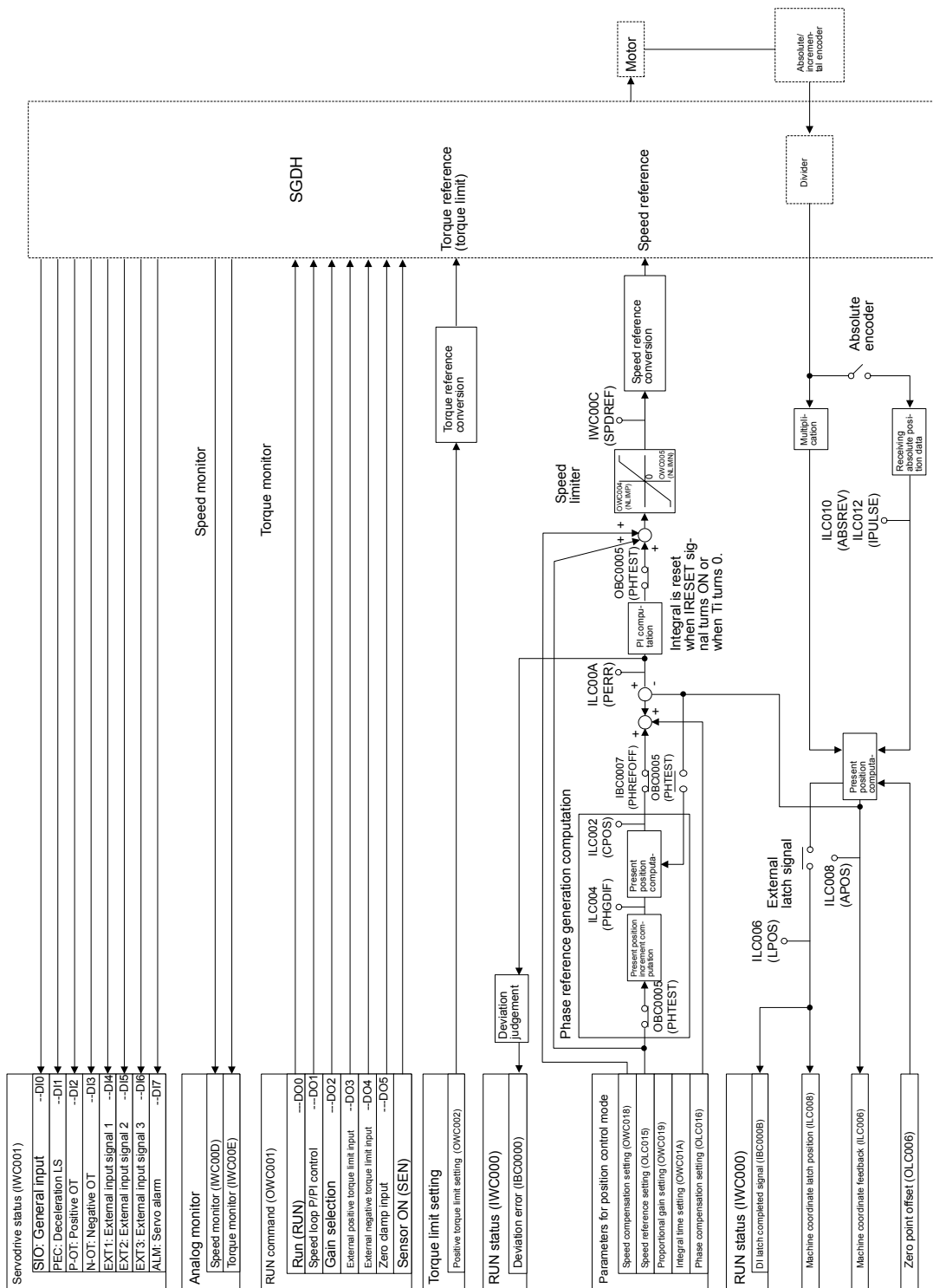

Fig 11.10 MP940 SVA Phase Control Mode Block Diagram

■ User Program Example 2: Electronic Cam

Example of RUN Operation

Cams are one of the conventional methods for changing a rotational movement to a linear movement, and they are used to obtain the desired operation curve (displacement drawing) during a cycle.

- A mechanical cam forms a cam with a shape corresponding to this displacement drawing. Placing a follower on the circumference and rotating the cam enables the desired linear operation to be obtained.
- An electronic cam holds the actual displacement drawing data in the controller as a position pattern, and performs regular position control for the so-called continuous path (CP) by changing the phase.

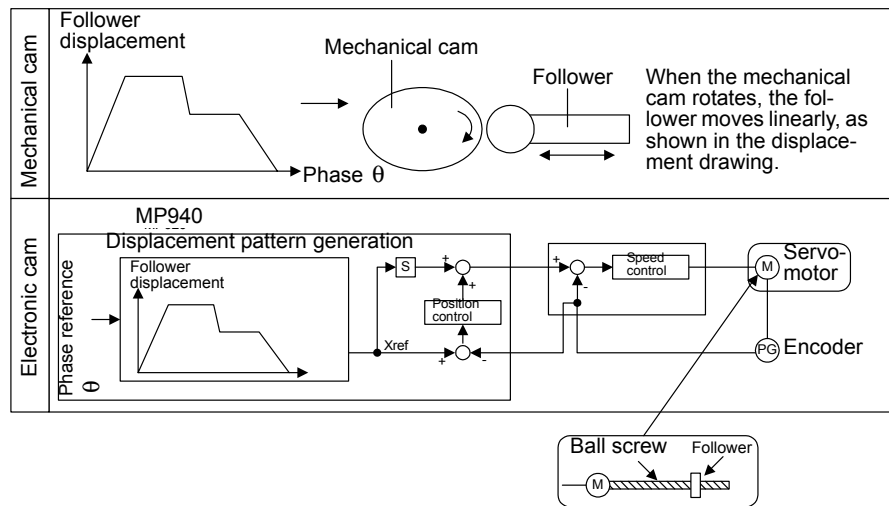

An electronic cam control loop can be configured using phase control. With normal phase control, the position reference is generated by integrating the reference speed reference into the SVA Module (see Fig. 11.11).

An electronic cam control loop cuts the integral circuit of the reference speed reference, and provides the position reference from the phase compensation settings (see Fig. 11.12).

The following illustration shows a block diagram of a phase control loop.

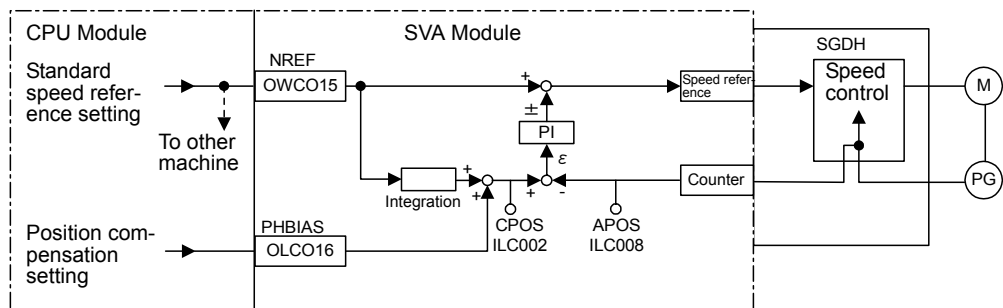

Fig 11.11 Block Diagram of Phase Control Loop

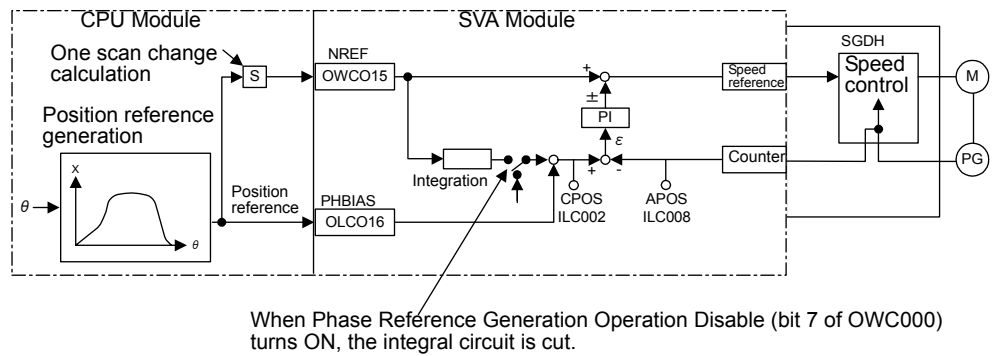
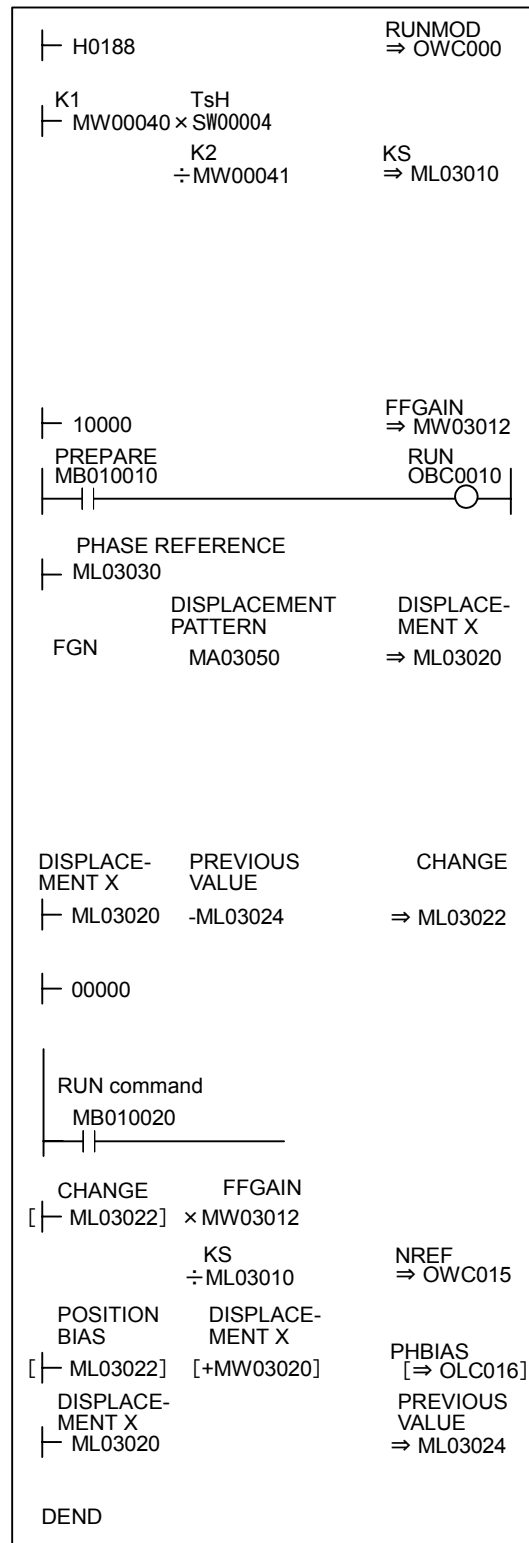

Fig 11.12 Block Diagram of Electronic Cam Control Loop

The electronic cam control loop is processed in the SVA Module. Therefore, the user can easily control the electronic cam simply by selecting the phase control mode on the CPU Module and providing the required parameters for the SVA Module.

Ladder Logic Program Example



Set the phase control mode to ON.
Set Phase Reference Generation Operation Disable to ON.

Calculate the speed scaling constant (ks).

High-speed scan setting: SW0004

$$\frac{NR \times FBppr \times n}{60 \times 10^4} \rightarrow \begin{matrix} \text{Numerator} * MW00040 \\ \text{Denominator} * MW00041 \end{matrix}$$

NR = Rated speed
FBppr = Number of feedback pulses
n = Number of pulse multipliers (1, 2, or 4)

Reduce the fraction to the lowest terms so that it can be stored as one word.

Feed forward gain [10000/100%]

Driver RUN command (RUN)
When MB01010 turns ON, phase control starts.

The phase reference displacement [pulse] is read from the FGN function.

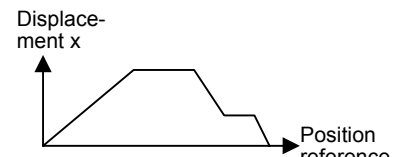

The FGN pattern is set in advance.

Changes [pulses] per scan

When RUN command MB010020 turns ON, the machine operates at the reference speed NREF. When MB010020 turns OFF, the reference speed NREF remains at "0."

Standard speed reference setting [0.01%]

Phase compensation setting [pulse]

Phase reference previous displacement value [pulse]

Fig 11.13 RUN Command (DWG H04)

The example in the above illustration has been greatly simplified. In actual operation, each register can be controlled from the user program.

11.2.5 Zero Point Return Mode

Overview

The zero point return operation returns the machine to the machine-specific zero point. When an incremental encoder is used, the system zero point position data is destroyed if the power supply is disconnected. Therefore, after turning ON the power, the system zero point must be repositioned. As a general rule, a pulse generator (PG) with a zero point pulse and a limit switch showing the zero point area are used to determine the zero point.

There are two zero point return methods. One method uses motion commands, and the other method uses the zero point return control mode. Care is required because zero point return operations are different with these two methods.

Using the zero point return mode is explained below.

When an absolute encoder is used, position reference "0" will be the position control when zero point return is selected.

Details

Use the following procedure to perform operation in the zero point return mode.

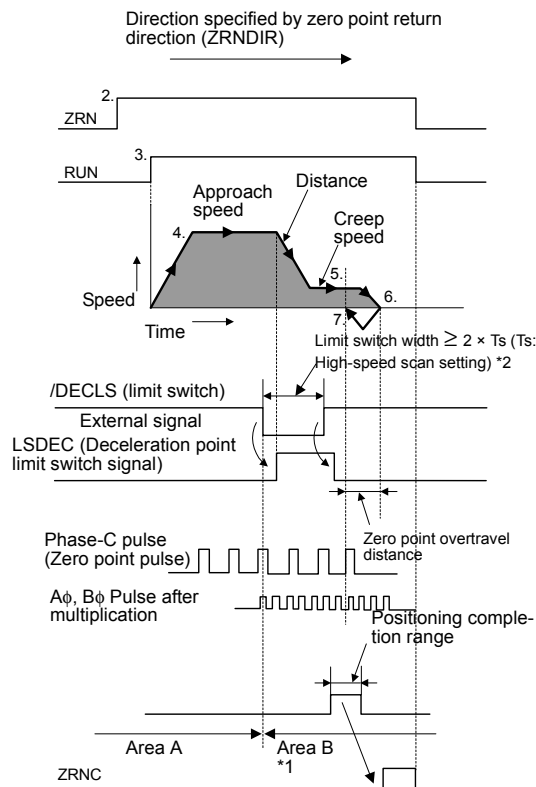
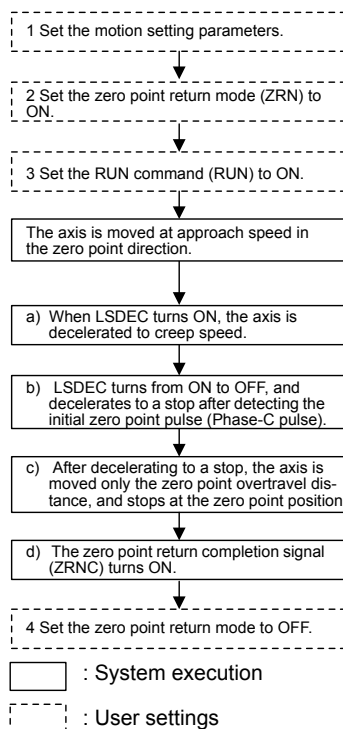

* 1. If the machine is in Area B after the power is turned ON, a return cannot be performed correctly. Be sure to move the machine back to Area A before performing a return.

* 2. The limit switch (/DECLS) width must be at least twice that of the high-speed scan setting.

1. Set the motion parameters.

The following three methods can be used to set the setting parameters.

- Using the CP-717 Setting Parameter Screen
- Using a ladder logic program
- Using a motion program

Table 11.4 Examples of Setting Parameters

Name	Register No.	Setting Range	Meaning	Setting Example
Positive Torque Limit Setting (TLIMP)	OWC002	-327.68 to 327.67	0.01 = 0.01% 1 = 1%	-100.00 (-100.00%)
Positive Speed Limiter Setting (NLIMP)	OWC004	0.00 to 327.67	0.01 = 0.01% 1 = 1%	130.00 (130.00%)
Negative Speed Limiter Setting (NLIMN)	OWC005	0.00 to 327.67	0.01 = 0.01% 1 = 1%	130.00 (130.00%)
Machine Coordinate System Zero Point Offset (ABSOFF)	OLC006	-2^{31} to $2^{31}-1$	1 = 1 reference unit With pulse: 1 = 1 pulse	100 pulses
Approach Speed Setting (NAPR)	OWC00A	0 to 32767	Value (%) for rated speed: 1 = 0.01%	2000 (20.00%)
Creep Speed Setting (NCLP)	OWC00B	0 to 32767	Value (%) for rated speed: 1 = 0.01%	1000 (10.00%)
Linear Acceleration Time Constant (NACC)	OWC00C	0 to 32767	Linear acceleration time constant (ms) at speed pattern generation	1000 (1 second)
Linear Deceleration Time Constant (NDEC)	OWC00D	0 to 32767	Linear deceleration time constant (ms) at speed pattern generation	1000 (1 second)
Positioning Completed Range Setting (PEXT)	OWC00E	0 to 65535	1 = 1 reference unit With pulse: 1 = 1 pulse	10 pulses
Error Count Alarm Detection Setting (EOV)	OWC00F	0 to 32767	1 = 1 reference unit With pulse: 1 = 1 pulse	65535 pulses
Position Loop Gain Setting (KP)	OWC010	0.0 to 3276.7	0.1 = 0.1 /s 1 = 1 /s	30.0 (30.0 /s)
Filter Time Constant (NNUM)	OWC014	0 to 255	For simple S-curved acceleration	0

2. Set the Zero Point Return Mode (ZRN) to ON (bit 4 of OWC000).

3. Set the Servo ON (RUN) to ON (bit 0 of OWC001).

a) The axis will be moved in the direction specified by the Zero Point Return Direction Selection ZRNDIR (bit 9 of OWC000).

b) When the Zero Point Return Deceleration Point Limit Switch LSDEC (bit 15 of OWC001) turns ON, the axis is decelerated to creep speed.

IMPORTANT

A user program must be created to connect the Limit Switch Signal DECLS (the DI signal included in the LIO Module) to the Zero Point Return Deceleration Point Limit Switch LSDEC (bit 15 of OWC001).

- c) When LSDEC turns from ON to OFF, the point detected by the initial zero point pulse (Phase-C pulse) is the zero point position. The axis is decelerated to a stop after detecting the initial zero point pulse.
 - d) After decelerating to a stop, the axis is moved only the zero point overtravel distance at creep speed in the zero point position direction and stops at the zero point position. A zero point position offset value can also be set. (If Machine Coordinate System Zero Point Offset OLC006 is set in advance to 100, the position data will be 100.)
4. End of Zero Point Return Mode

The zero point return operation is completed when the axis enters the positioning completed range. When the zero point return operation is completed, the Zero Point Return Completed Signal ZRNC (bit F of IWC000) turns ON. After checking that the zero point return completion signal (ZRNC) is turned ON, set the RUN command (RUN) and the zero point return mode (ZRN) to OFF.

■ User Program Example

Example of RUN Operation

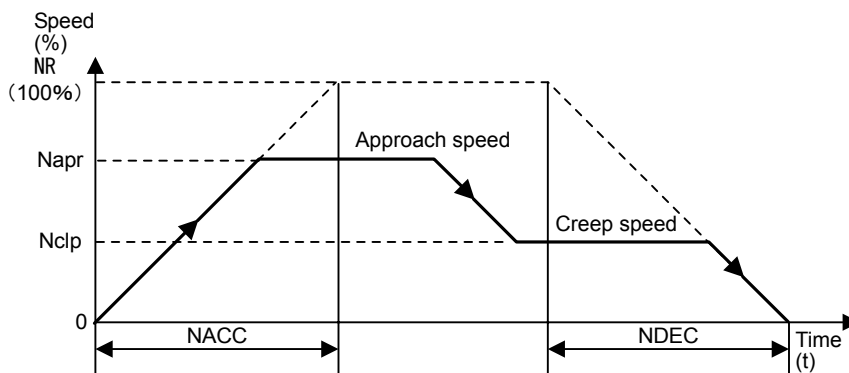

Fig 11.14 Zero Point Return Pattern

Operating Conditions

Input a limit switch signal width at least twice that of the high-speed scan setting.

Ladder Logic Program Example

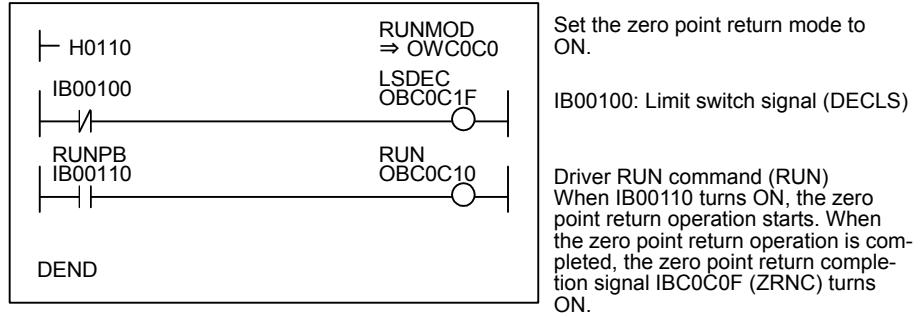

Fig 11.15 RUN Commands (DWG H01)

The example in the above illustration has been greatly simplified. In actual operation, each register can be controlled from the user program.

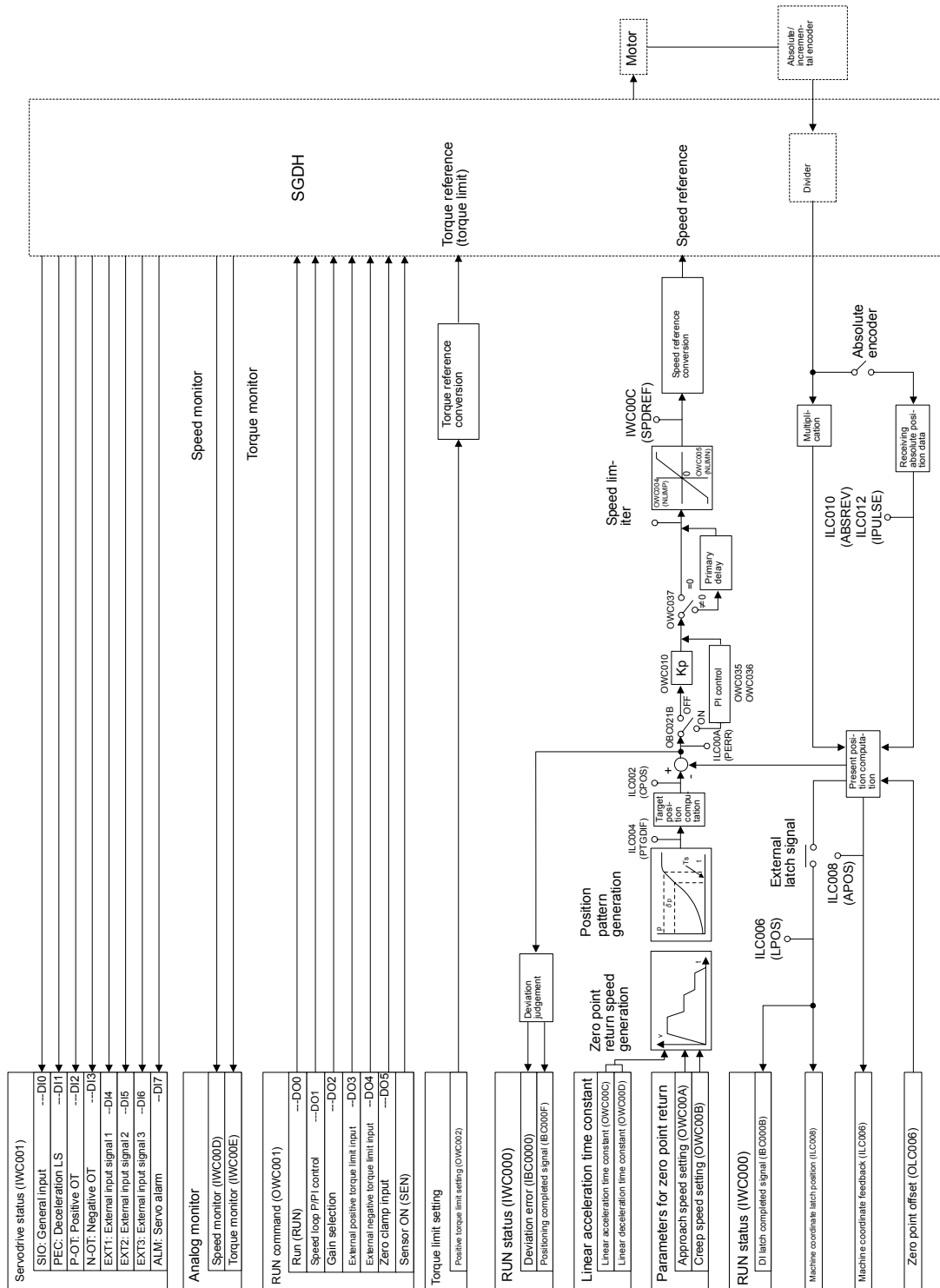

Fig 11.16 MP940 SVA Zero Point Return Mode Block Diagram

11.3 Position Control

This section describes the prerequisites for position control, and position control without using motion commands.

11.3.1 Prerequisites for Position Control

■ Overview of Position Control

With position control, the axis is moved to the target position, stops there, and holds that position (servo clamp).

An incremental encoder or a Yaskawa absolute encoder is used as the position detector. When a Yaskawa absolute encoder is used, the absolute position is stored, even when the power for the machine (positioning device) is disconnected. Therefore, when the power is turned ON again, the zero point return operation is not required.

There are two position control methods. One method uses motion commands (OWC020), and the other method does not use motion commands.

Whether or not motion commands (OWC020) are to be used is set in the motion parameters shown in the following table.

Motion Parameter	Motion Command (OWC020) Not Used	Motion Command (OWC020) Used
Motion fixed parameter No. 14 Bit 7 of Additional Function Selections (Motion Command Selection)	0 (= Not used)	1 (= Used)
Motion setting parameter Bit 8 of RUN Mode Settings (OWC000) (Motion Command Code Enable/Disable)	0 (= Disabled)	1 (= Enabled)

Note: When bit 7 (motion command selection) of motion fixed parameter No. 14 (Additional Function Selections) is not selected for use and bit 8 (motion command code enable) of the RUN Mode Settings (OWC000) motion setting parameter is set to "1" (= enabled), the axis is controlled without motion commands (OWC020).

IMPORTANT

Be sure to set the motion set parameter OWC001 bit 14 (Position Reference Type) to 1 (= incremental addition mode) when using the motion program.

The following table shows the differences when motion commands (OWC020) are used, and when no motion commands are used.

Table 11.5 Differences When Motion Commands are Used/Not Used

Item	Motion Commands (OWC020) Not Used	Motion Commands (OWC020) Used
Reference Unit	Pulse	Pulse, mm, inch, or deg can be selected.
Electronic Gear Function	Not possible	Possible
Finite length position control	Possible	Possible
Infinite length position control that rotates the axis in one direction only, without resetting after one rotation	Possible	Possible
Infinite length position control that resets the axis after one rotation	Not possible	Possible
Position reference	Absolute position mode	Absolute position mode or incremental addition mode can be selected.
Position buffer	Not possible	Possible
Position monitor	Pulse unit	Reference unit
Speed reference	Percentage (%) reference	The percentage (%) reference or the reference unit can be selected.

The meaning of the terms used in the above table and their method of application are discussed below.

■ Reference Unit

The reference units input to the Module are set with the following motion fixed parameter settings.

Pulses, millimeters, degrees, or inches can be used as the reference unit. The reference unit is specified in bits 0 to 3 of motion fixed parameter No. 17 (Motion Controller Function Selection Flags).

The minimum reference unit that can be specified in the Module is determined by the above unit settings and the setting of motion fixed parameter No. 18 (Number of Digits Below Decimal Point).

When motion commands (OWC020) are not used, the unit will be the pulse.

Table 11.6 Minimum Reference Unit (1 Reference Unit)

Number of Digits Below Decimal	Unit	Motion Fixed Parameter No. 17 Bits 0 to 3 of Motion Controller Function Selection Flags			
		Pulse (= 0)	mm (= 1)	deg (= 2)	inch (= 3)
0		1 pulse	1 mm	1 deg	1 inch
1		1 pulse	0.1 mm	0.1 deg	0.1 inch
2		1 pulse	0.01 mm	0.01 deg	0.01 inch
3		1 pulse	0.001 mm	0.001 deg	0.001 inch
4		1 pulse	0.0001 mm	0.0001 deg	0.0001 inch
5		1 pulse	0.00001 mm	0.00001 deg	0.00001 inch

Note: The number of digits below the decimal point is specified in motion fixed parameter No. 18 (Number of Digits Below Decimal Point).

■ Electronic Gear

In contrast to the reference unit input to the Module, the mechanical travel unit is called the “output unit.”

The electronic gear converts position or speed units from reference units (millimeters, degrees, or inches) to output units (millimeters, degrees, or inches).

When the axis at the motor has rotated m times and the mechanical configuration allows the axis at the load to rotate n times, this electronic gear function can be used to make the reference unit equal to the output unit.

The electronic gear function is set in the motion setting parameters shown in the following table.

Table 11.7 Electronic Gear Parameters

Motion Fixed Parameter	Name and Meaning
No. 17 Bit 4 of Motion Controller Function Selection Flags	Electronic gear enabled selection (0: Disabled, 1: Enabled) • Disabled when the unit selected is the pulse. Set Disabled (= 0).
No. 19 Distance Travelled per Machine Rotation	Travel distance per machine rotation • This parameter setting is invalid when Disabled (= 0) is set for the electronic gear enabled selection.
No. 21 Servomotor Gear Ratio	Motor side gear ratio • This parameter setting is invalid when Disabled (= 0) is set for the electronic gear enabled selection.
No. 22 Machine Gear Ratio	Machine side gear ratio • This parameter setting is invalid when Disabled (= 0) is set for the electronic gear enabled selection.

When the unit selected is the pulse and motion commands (OWC020) are not used, the electronic gear function is disabled.

The following table shows the meanings of the above parameters and gives some setting examples.

Table 11.8 Electronic Gear Parameters and Constant Table

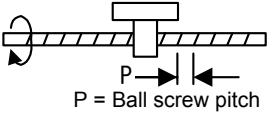
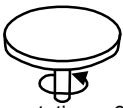
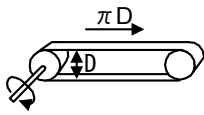
Servo Fixed Parameter No.	Name	Description	Initial Value	
No. 19	Distance Travelled Per Machine Rotation	<ul style="list-style-type: none"> This parameter shows the load travel distance for each rotation of the load axis. Sets the load travel distance value divided by the minimum reference unit. $\text{No. 19} = \frac{\text{Load travel distance for each rotation of the load axis}}{\text{Minimum reference}}$ <ul style="list-style-type: none"> Some examples of the load travel distance are shown below. 	10000	
		Distance Travelled Per Machine Rotation		Load Configuration Examples
		P [mm]		Ball screw  <p>P = Ball screw pitch</p>
		360 [°]		Round table  <p>One rotation = 360°</p>
		πD [mm]		Belt 
		<ul style="list-style-type: none"> No. 19 setting range: 1 to $2^{31} - 1$ [1 = 1 reference unit] Setting Examples <ul style="list-style-type: none"> Load travel distance per load axis rotation = 12 mm Minimum reference unit = 0.001 mm [reference unit: mm, digit number after decimal point: 3] $\text{No.19} = \frac{12\text{mm}}{0.001\text{mm}} = 12000$		

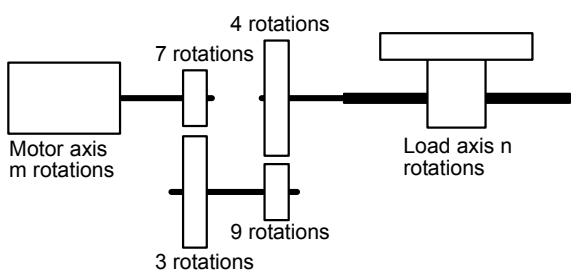
Servo Fixed Parameter No.	Name	Description	Initial Value
No. 21	Servomotor Gear Ratio	<ul style="list-style-type: none"> These parameters are used to set the gear ratio between the motor and the load. When the motor axis has rotated m times and the mechanical configuration allows the load axis to rotate n times, set the following values: $\left\{ \begin{array}{l} \text{No. 21} = m \text{ rotations} \\ \text{No. 22} = n \text{ rotations} \end{array} \right.$ Setting range: 1 to 65,535 [rotations] <p>Setting Examples</p>  $\text{Gear ratio} = \frac{n}{m} = \frac{3}{7} \times \frac{4}{9} = \frac{4}{21}$ <p>Therefore, set the following values: No. 21 = 21 No. 22 = 4</p>	1
No. 22	Machine Gear Ratio		1

Electronic Gear Parameter Setting Example (A): With Ball Screw

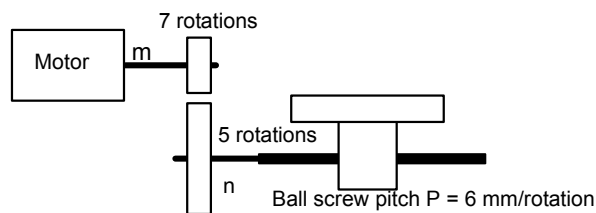

In the above machine system, if the requirement is reference unit = output unit = 0.001 mm, the setting of each parameter will be as follows:

- No.19 = $\frac{6\text{mm}}{0.001\text{mm}} = \mathbf{6000}$
- Gear ratio = $n/m = 5/7$
- No.21 = **7**
- No.22 = **5**

Electronic Gear Parameter Setting Example (B): Rotating Load

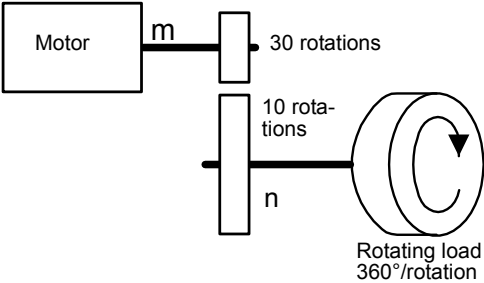

In the above machine system, if the requirement is reference unit = output unit = 0.1°, the setting of each parameter will be as follows:

- No.19 = $\frac{360^\circ}{0.1^\circ} = \mathbf{3600}$
- Gear ratio = $n/m = 10/30 = 1/3$
- No.21 = **3**
- No.22 = **1**

■ Axis Selection

There are two types of position control: Finite length position control, where return and other operations are performed only within a specified range, i.e., within a prescribed positioning interval, and infinite length position control, which is used for rotation in one direction only.

There are two infinite length position control methods. One method involves resetting the conveyor belt or other device to “0” after one rotation; the other method involves rotating the conveyor belt in one direction only, without resetting after one rotation.

Axis selection involves selecting which of these types of position control is to be used. The axis selection is set in bit 5 of motion fixed parameter No. 17 (Motion Controller Function Selection Flags).

When motion commands (OWC020) are not used, axis selection is disabled. (Set as a finite length axis (= 0).)

Table 11.9 Axis Selections

Types of Position Control	Axis Selection
Finite length position control	Finite length axis (= 0)
Infinite length position control that rotates the axis in one direction only, without resetting after one rotation	Finite length axis (= 0)
Infinite length position control that resets the axis after one rotation*	Infinite length axis (= 1)

* The reset position is set in motion fixed parameter No. 23 (Infinite Length Axis Reset Position).

■ Position Reference

There are two methods of setting the position reference: Direct designation, which directly sets the position reference in OLC012, and indirect designation, which specifies the number of the position buffer from which the position reference is stored in OLC012.

There are two direct designation methods: The absolute position reference mode, in which the absolute position is set in OLC012, and the incremental addition mode, in which the present travel distance is added to the previous position reference value (previous value of OLC012).

The following table shows the parameters relating to the position reference.

Table 11.10 Position Reference Parameters

Parameter Type	Parameter No. (Register No.)	Name	Description	Initial Value
Motion Setting Parameters	Bit 12 of OWC001	Position Reference Value Selection	Sets the position reference designation method. <ul style="list-style-type: none"> • 0: Direct designation Directly sets the position data in OLC012. Specifies in bit 14 of OWC001 whether the position data is to be set in the absolute position mode or the incremental addition mode. • 1: Indirect designation Sets the number of the position buffer in OLC012. The absolute position must first be stored in the specified position buffer. 	0
	Bit 14 of OWC001	Position Reference Type	Specifies the type of position data. <ul style="list-style-type: none"> • 0: Absolute position mode Sets the absolute position in OLC012. • 1: Incremental addition mode Adds the present travel distance value to the previous value of OLC012 and sets the result in OLC012.*1 	1
	OLC012	Position Reference Setting	Sets the position data.*2	0

* 1. This parameter is invalid when the position reference value selection is the position buffer (indirect designation).

* 2. The setting data differs according to the setting of the Position Reference Value Selection (bit 12 of OWC001) and the Position Reference Type (bit 14 of OWC001).

IMPORTANT

- When indirect designation is used to specify the position buffer number, the positions stored in the position buffer are treated as absolute positions.
When a motion command (OWC020) is not used, the position reference value set in OLC012 is treated as an absolute position.
- Be sure to set the motion set parameter OWC001 bit 14 (Position Reference Type) to 1 (= incremental addition mode) when using the motion program.

Table 11.11 Position Reference Value Selection

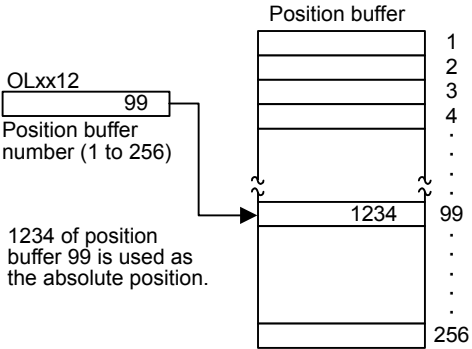
Position Reference Value Selection (Bit 12 of OWC001)	Position Reference Type (Bit 14 of OWC001)	Position Reference (OLC012)
0 (Direct designation)	0 (Absolute position mode)	Sets the absolute position. (Moves to the setting position.) Example: OLC012 ← 10000 OLC012 ← 20000
	1 (Incremental addition mode)	Sets the present travel distance value (increment) added to the previous value of OLC012. OLC012 ← Previous OLC012 + Incremental travel distance Example: When the previous OLC012 = 1,000 and the present travel distance is 500, then: OLC012 ← 1000 + 500 = 1500
1 (Indirect designation)	0 (Absolute position mode)	<p>Sets the position buffer number.</p>  <p>The absolute position must be stored in advance in the position buffer with the specified number.</p>

11

With the position reference for an infinite length axis, the present travel distance (incremental travel distance) is added to the previous position reference (OLC012), and the position reference (OLC012) is reset. The position reference (OLC012) must not be set in the range of 0 to (infinite length axis reset position - 1).

Position Buffers

The position buffers are a collection of position data stored in the SVA Module, and a maximum of 256 points can be stored for each axis. They are used for the position data when POSITIONING and other motion commands are executed. Continuous operation is enabled by storing the position data in advance, and by using a simple program that only specifies the points.

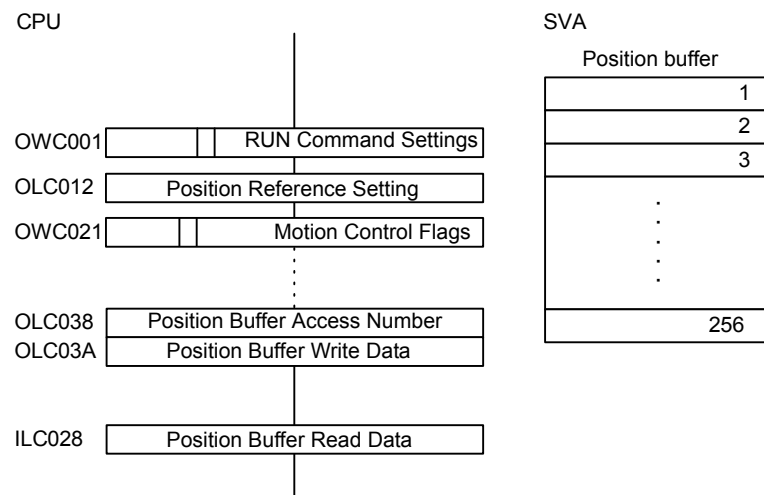

Using the Position Buffers

By first storing in the position buffers the position information for a machine whose operating pattern has been determined in advance, continuous positioning of up to 256 points is enabled simply by refreshing the buffer pointer at the completion of a single-block operation.

Reading/Writing Position Buffers

1. Writing to Position Buffers

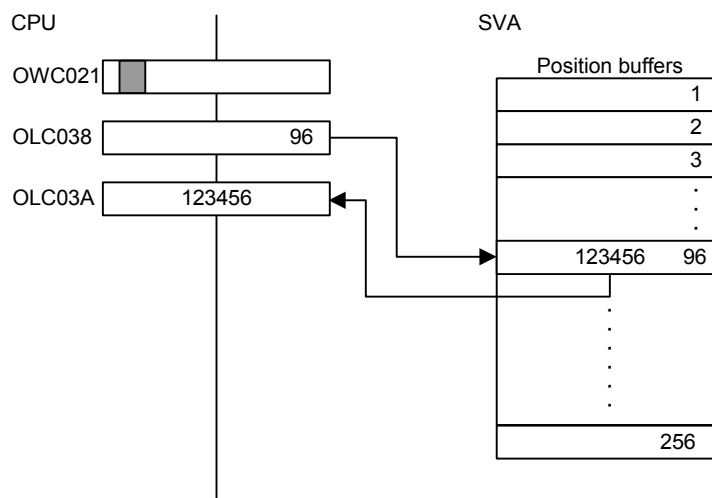

- a) Set the Position Buffer Access Number (OLC038). Any number between 1 and 256 can be set.
- b) Set the Position Buffer Write Data (OLC03A).
- c) Set Position Buffer Write (OBC021E) in the Motion Command Control Flags to ON.

2. Reading Position Buffers

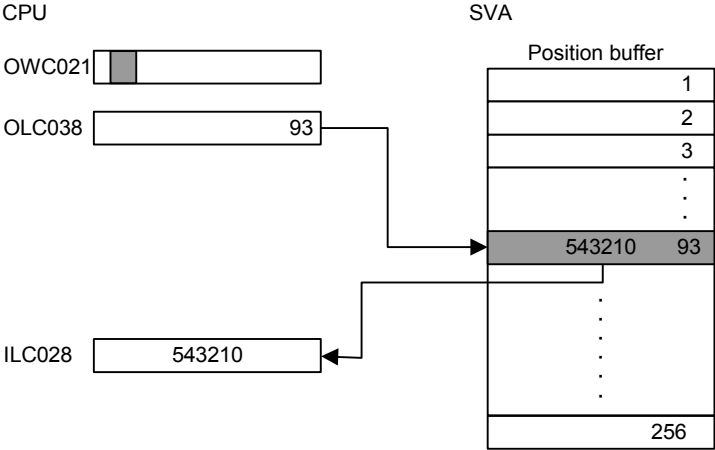

- a) Set the Position Buffer Access Number (OLC038). Any number between 1 and 256 can be set.
- b) Set Position Buffer Read (OBC021F) in the Motion Command Control Flags to ON.
- c) After scanning, the position data specified in Position Buffer Read Data (ILC028) will be stored.



- Position buffers can be used only when motion commands are used in the position control mode.
- The position data specified in the position buffers are absolute position references.

IMPORTANT

The data in the position buffers is deleted by turning OFF the power and resetting the CPU Module Master. Be sure to set the data when the power is turned ON, or before using the position buffers.

Using the Position Buffers as Position References

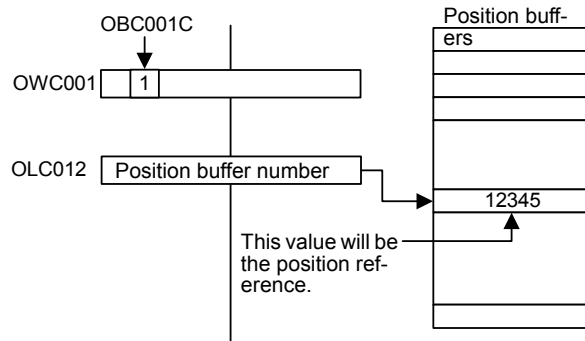

1. Set bit 12 of the RUN Command Settings (OWC001) to ON.
2. Set a position buffer number 1 to 256 in place of the position reference in the Position Reference Setting (OLC012).

In this way, the data for the position buffer number specified in OLC012 functions as the position reference.

■ Position Monitoring

The following table shows the parameters used to monitor positioning.

Table 11.12 Position Monitor Parameters

Motion Monitor Parameter No. (Register No.)	Name	Description
ILC002	Calculated Position in the Machine Coordinate System ¹ (CPOS)	The calculated position of the machine coordinate system managed by the SVA Module is reported. Normally, the position data reported in this parameter will be the target position for each scan.*1
ILC008	Machine Coordinate System Feedback Position (APOS)	The feedback position of the machine coordinate system is reported.*2
ILC018	Machine Coordinate System Reference Position (MPOS)	The position output externally by the SVA Module and the reference position of the machine coordinate system are reported. In machine lock status, this data is not refreshed. (With the machine lock status, the data is not output externally.) When the machine lock function is not used, this position is the same as that in ILC002.
ILC02E	Calculated Reference Coordinate System Position (POS)	This position is significant when the axis selected is an infinite length axis. With an infinite length axis, the target position for each scan corresponding to the position reference in this parameter is reported.*3



¹ Machine Coordinate System

The basic coordinate system that is set according to the zero point return mode execution, the Zero Point Return (ZRET) motion command execution, or the Zero Point Setting (ZSET) motion command operation. The SVA Module manages the positions using this machine coordinate system.

- * 1. When an infinite length axis is selected, a range of 0 to (infinite length axis reset position - 1) is reported.
With the position reference for an infinite length axis, the present travel distance (incremental travel distance) is added to the previous position reference (OLC012), and reset as the position reference (OLC012).
The position reference (OLC012) must not be set in the range of 0 to (infinite length axis reset position - 1).
- * 2. When an infinite length axis is selected, a range of 0 to (infinite length axis reset position - 1) is reported.
- * 3. With a finite length axis, this position is the same as that in ILC002.

■ Speed Reference

There are two methods of setting the speed reference. One method involves using a reference unit for the speed reference setting, such as the rapid traverse speed, approach speed, or creep speed. The other method involves setting the percentage (%) corresponding to the rated speed.

The following table shows the parameters relating to the speed reference.

Table 11.13 Speed Reference Parameters

Parameter Type	Parameter No. (Register No.)	Name	Description
Motion Setting Parameters	Bit 13 of OWC001	Speed Reference Value Selection	Specifies the setting unit for the rapid traverse speed, approach speed, and creep speed, and specifies the register number for the rapid traverse speed. 0: Specifies the speed using a reference unit, and sets the Rapid Traverse Speed in OLC022. 1: Specifies the speed using the percentage (%) corresponding to the rated speed, and sets the Rapid Traverse Speed in OWC015.
	OWC00A	Approach Speed Setting	Sets the zero point return (ZRET) approach speed. The unit varies according to the Speed Reference Selection (bit 13 of OWC001).
	OWC00B	Creep Speed Setting	Sets the zero point return (ZRET) creep speed. The unit varies according to the Speed Reference Selection (bit 13 of OWC001).
	OWC015	Speed Reference Setting	This setting is valid when the Speed Reference Selection (bit 13 of OWC001) is "1." Sets the percentage (1 = 0.01%) corresponding to the rated speed as the rapid traverse speed.
	OLC022	Rapid Traverse Speed	This speed is valid when the Speed Reference Selection (bit 13 of OWC001) is "0." Set the rapid traverse speed using the reference unit.
	OWC02C	Override	Changes the actual rapid traverse speed.

When Motion Commands Are Not Used

When motion commands are not used, the Speed Reference Selection Flags are disabled, and the speed-related parameters have the meanings shown in the following table.

Parameter No.	Name	Description
Bit 3 of OWC001	Speed Reference Value Selection	Invalid
OWC00A	Approach Speed Setting	Specified as a percentage (%) of the rated speed.
OWC00B	Creep Speed Setting	Specified as a percentage (%) of the rated speed.
OWC015	Speed Reference Setting	The rapid traverse speed is specified as a percentage (%) of the rated speed.
OLC022	Rapid Traverse Speed	Invalid
OWC02C	Override	Invalid

When Motion Commands Are Used

When motion commands are used, the meanings of the speed-related parameters differ according to the Speed Reference Selection (bit 13 of OWC001).

Bit 13 of OWC001	Parameter No.	Name	Description
0	OWC00A	Approach Speed Setting	Specified using the reference unit.
	OWC00B	Creep Speed Setting	Specified using the reference unit.
	OWC015	Speed Reference Setting	Invalid
	OWC022	Rapid Traverse Speed	Specified using the reference unit.
	OWC02C	Override	Valid
1	OWC00A	Approach Speed Setting	Specified as a percentage (%) of the rated speed.
	OWC00B	Creep Speed Setting	Specified as a percentage (%) of the rated speed.
	OWC015	Speed Reference Setting	The rapid traverse speed is specified as a percentage (%) of the rated speed.
	OWC022	Rapid Traverse Speed	Invalid
	OWC02C	Override	Valid

The following table shows some examples of the parameter settings.

Table 11.14 Parameter Setting Examples

Parameter Type	Parameter No. (Register No.)	Name	Initial Value
Motion Setting Parameters	Bit 13 of OWC001	Speed Reference Value Selection	0
	OWC00A	Approach Speed Setting	0
	OWC00B	Creep Speed Setting	0
	OWC015	Speed Reference Setting	0
	OWC022	Rapid Traverse Speed	0
	OWC02C	Override*	100%
• Description Pulse counting method = A/B mode (fixed at $\times 4$ multiplication) Rated rotation = 3000 r/min. Feedback pulse = 2048 P/R Rated speed = 3,000 r/min $= 3000 \times 2048 \times 4$ $= 2575000 \text{ ppm}$ Various parameter setting examples are given below.			

* Select Enabled (= 1) in bit 9 (override enabled selection) of motion fixed parameter No. 17.



The rated rotation and feedback pulse per motor rotation are automatically transmitted to the MP940 connected to the SGDH SERVOPACK when the power is turned ON.

The pulse counting method is A/B mode (fixed at $\times 4$ multiplication).

Parameter Setting Examples

1. Speed Reference Value Selection Set to “0”

a) Pulses Selected as the Unit

When you wish to perform operations with the fixed parameters set for a rapid traverse speed of 1,500 r/min, an approach speed of 300 r/min, and a creep speed of 150 r/min, use the following settings.

- $OWC00A = 300 \text{ (r/min)} \times 2048 \times 4 \text{ (ppr)} \div 1000 = 2457 \text{ (= 2457000 ppm)}$
- $OWC00B = 150 \text{ (r/min)} \times 2048 \times 4 \text{ (ppr)} \div 1000 = 1228 \text{ (= 1228000 ppm)}$
- $OWC015 = \text{--- (Invalid)}$
- $OLC022 = 1500 \text{ (r/min)} \times 2048 \times 4 \text{ (ppr)} \div 1000 = 12288 \text{ (= 12288000 ppm)}$
- $OWC02C = 10000 \text{ (100\%)}$

b) Millimeters Selected as the Unit

When you wish to perform operations with the fixed parameters set for a rapid traverse speed of 900 mm/min, an approach speed of 180 mm/min, and a creep speed of 90 mm/min in a machine configuration that moves the axis 10 mm in one rotation, use the following settings

- $OWC00A = 180$
- $OWC00B = 90$
- $OWC015 = \text{--- (Invalid)}$
- $OLC022 = 900$
- $OWC02C = 10000 \text{ (100\%)}$

2. Speed Reference Value Selection Set to “1”

When you wish perform operations with the fixed parameters set for a rapid traverse speed of 1,500 r/min, an approach speed of 300 r/min, and a creep speed of 150 r/min, use the following settings

- $OW_{xx}0A = \frac{300 \text{ (r / min)}}{3000 \text{ (r / min)}} \times 10000 = 1000 \text{ (10.00\%)}$
- $OW_{xx}0B = \frac{150 \text{ (r / min)}}{3000 \text{ (r / min)}} \times 10000 = 500 \text{ (5.00\%)}$
- $OW_{xx}15 = \frac{1500 \text{ (r / min)}}{3000 \text{ (r / min)}} \times 10000 = 5000 \text{ (50.00\%)}$
- $OLC022 = \text{--- (Invalid)}$
- $OWC02C = 10000 \text{ (100\%)}$

3. When you wish to leave the above speed reference settings unchanged, but halve the operating speed, use the following setting.

- $OWC02C = 5000 \text{ (50.00\%)}$

11.3.2 Precautions in Changing to Position Control Mode

Position operations when changing to the position control mode or when changing the position reference in the position control mode are described below.

■ Position Control Using Motion Commands

In relation to the present position, target position, and deceleration start position¹ when changing to the position control mode or when changing the position reference in the position control mode, positioning operations are classified into the following two patterns.

Deceleration start position

The position at which deceleration must be started in order to move to the target position in the value set for the deceleration time.

Pattern 1: Present position < Target position, Present position ≦ Deceleration start position

Speed is decelerated for a time set in the deceleration time setting.

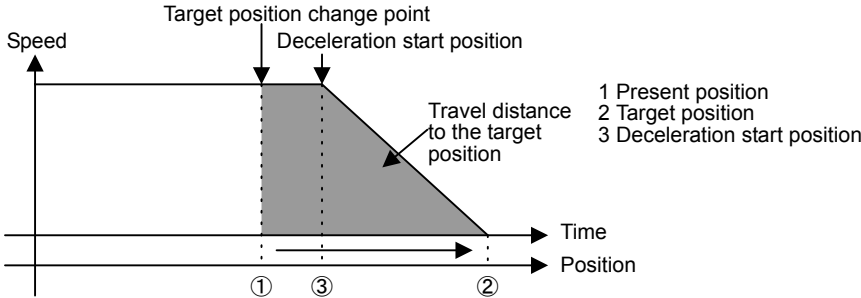

¹ Deceleration start position
The position at which deceleration must be started to position at the target position using the specified deceleration time setting.

Pattern 2: Present position < Target position, Present position > Deceleration start position

Deceleration stops after a time set in the deceleration time setting and then reverses the direction to perform positioning to the target position for a time set in the acceleration time setting.

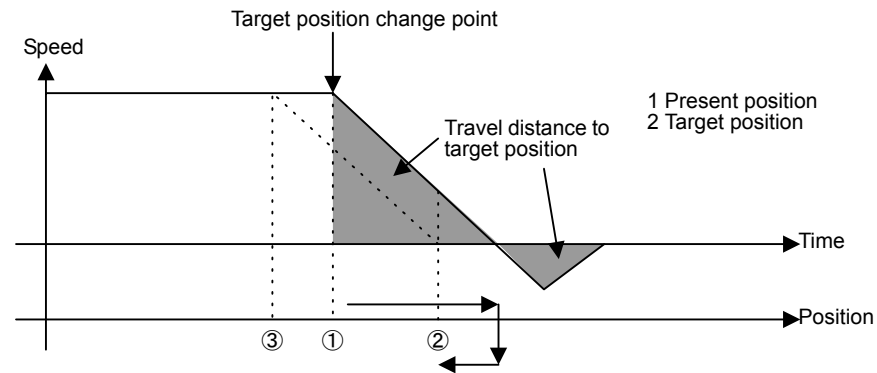

In the above illustration, deceleration should have started at point 3. However, after passing this point, deceleration started from the target position change point and stopped after a set time. From this stop point, positioning was performed to the target position.

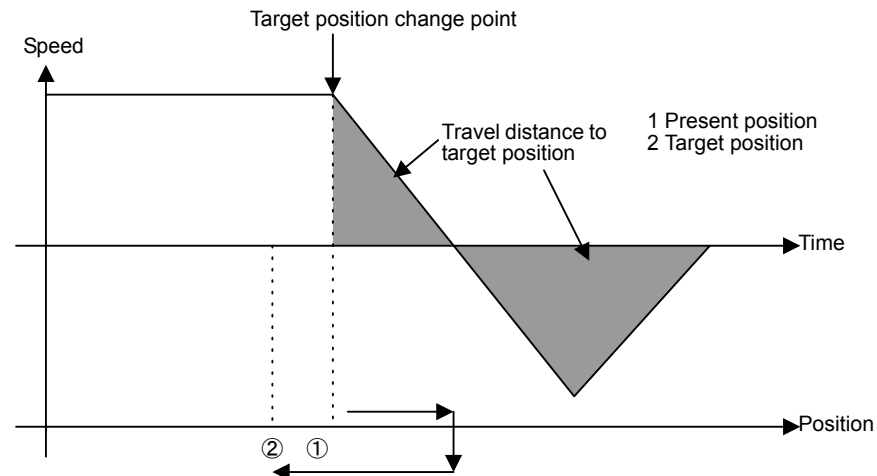

As the target position is located before the present position, the speed is decelerated to a stop and then, from this stop position, positioning is performed to the target position.

■ Position Control without Using Motion Commands

In relation to the zero point position, target position, and deceleration start position when changing to the position control mode or when changing the position reference in the position control mode, positioning operations are classified into the following three patterns.

Pattern 1: Present position < Target position, Present position ≤ Target position

Speed is decelerated for a time set in the deceleration time setting.

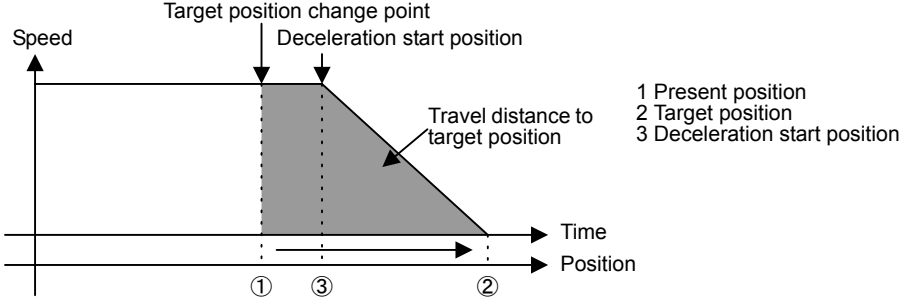

Pattern 2: Present position < Target position, Present position > Deceleration start position

Deceleration starts the time set in the deceleration time setting and comes to a stop when reaching the target position.

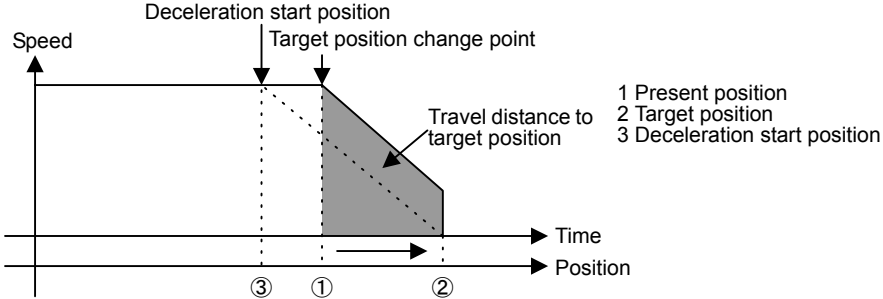

In the above illustration, deceleration should have started at point 3. However, after passing this point, deceleration started from the target position change point and came to a stop when reaching the target position.

Pattern 3: Present position \geq Target position

Deceleration stops after a time set in the deceleration time setting and then reverses the direction to perform positioning to the target position for a time set in the acceleration time setting.

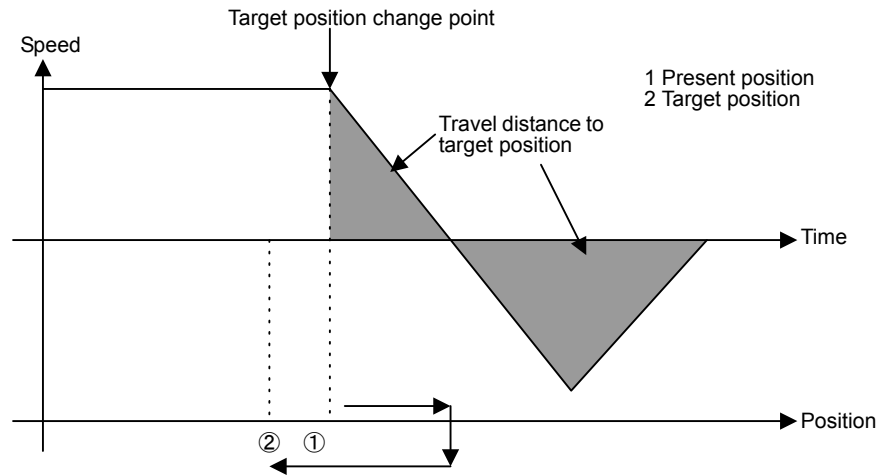

As the target position is located before the present position, the speed is decelerated to a stop and then, from this stop position, positioning is performed to the target position.

11.3.3 Position Control without Using Motion Commands

■ Overview

Position control performs speed acceleration/deceleration according to the related parameters, and positions the axis to the target position of the position reference setting parameter (OLC012).

■ Details

Use the following procedure to perform position control operations without using motion commands.

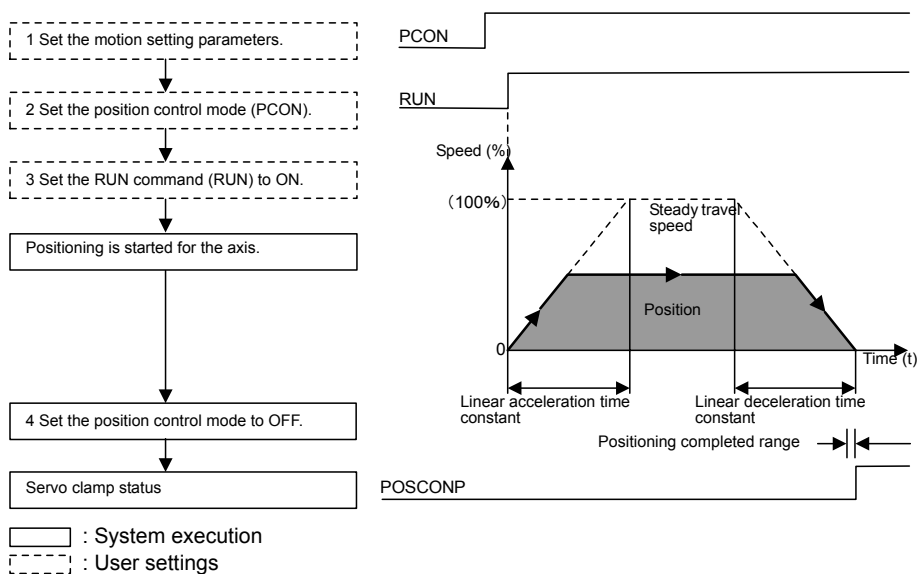

1. Set the motion parameters.

The following three methods can be used to set the setting parameters.

- Using the CP-717 Setting Parameter Screen
- Using a ladder logic program
- Using a motion program

Table 11.15 Examples of Setting Parameters

Name	Register No.	Setting Range	Meaning	Setting Example
Positive Torque Limit Setting (TLIMP)	OWC002	-327.68 to 327.67	0.01 = 0.01% 1 = 1%	-100.00 (-100.00%)
Positive Speed Limiter Setting (NLIMP)	OWC004	0.00 to 327.67	0.01 = 0.01% 1 = 1%	130.00 (130.00%)
Negative Speed Limiter Setting (NLIMN)	OWC005	0.00 to 327.67	0.01 = 0.01% 1 = 1%	130.00 (130.00%)
Machine Coordinate System Zero Point Offset (ABSOFF)	OLC006	-2^{31} to $2^{31}-1$	1 = 1 reference unit With pulse: 1 = 1 pulse	100 pulses

Name	Register No.	Setting Range	Meaning	Setting Example
Linear Acceleration Time Constant (NACC)	OWC00C	0 to 32767	Linear acceleration time constant (ms) at speed pattern generation	1000 (1 second)
Linear Deceleration Time Constant (NDEC)	OWC00D	0 to 32767	Linear deceleration time constant (ms) at speed pattern generation	1000 (1 second)
Positioning Completed Range Setting (PEXT)	OWC00E	0 to 65535	1 = 1 reference unit With pulse: 1 = 1 pulse	10 pulses
Error Count Alarm Detection Setting (EOV)	OWC00F	0 to 32767	1 = 1 reference unit With pulse: 1 = 1 pulse	65535 pulses
Position Loop Gain Setting (KP)	OWC010	0.0 to 3276.7	0.1 = 0.1 /s 1 = 1 /s	30.0 (30.0 /s)
Filter Time Constant (NNUM)	OWC014	0 to 255	For simple S-curved acceleration	0
Feed Forward Gain Setting (Kf)	OWC011	0 to 200	1 = 1%	0
Position Reference Setting (XREF)	OLC012	-2^{31} to $2^{31}-1$	1 = 1 reference unit With pulse: 1 = 1 pulse	10000 pulses
Speed Reference Setting (NREF)	OWC015	-327.68 to 327.67	Speed reference value 0.01 = 0.01% 1 = 1%	50.00 (50.00%)

2. Select the Position Control Mode (PCON) (bit 2 of OWC000).

3. Set the Servo ON (RUN) to ON (bit 0 of OWC001).

The axis is positioned according to the specified motion parameters.

Even during positioning, the motion parameter settings can be changed.

4. To stop position control, set the RUN command (RUN) and the position control mode (PCON) to OFF.

The POSCOMP Positioning Completed Signal (bit D of IWC000) turns ON when the axis enters the positioning completed range. Control continues even when the axis enters the positioning completed range (the axis enters servo clamp status).

■ User Program Example

Example of RUN Operation

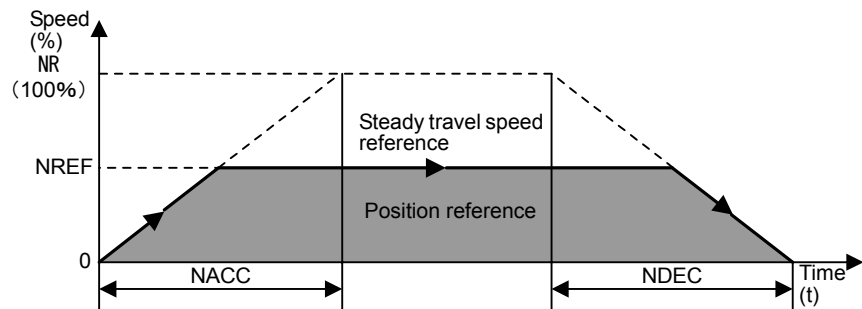

Fig 11.17 Position Pattern

Operating Conditions

In the pattern shown in the above illustration on the previous page, the axis is stopped at an absolute position of 10000 (pulses).

- Position reference: XREF = 10000 (pulses)

Ladder Logic Program Example

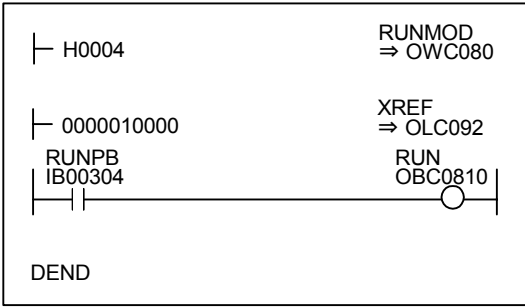

Set the position control mode to ON.

Position reference pulse (XREF)
(Absolute position: 10000)
Driver RUN command (RUN)

When IB00304 turns ON, position control starts, and the axis is moved to absolute position 10000. When absolute position 10000 is reached, the IBC080D positioning completed signal turns ON.

Fig 11.18 RUN Commands (DWG H03)

The example in the above illustration has been greatly simplified. In actual operation, each register can be controlled from the user program.

11.4 Position Control Using Motion Commands

This section describes position control using motion commands.

11.4.1 Overview of Motion Commands

The following table lists the motion commands and gives an overview of each.

Command	Name	Description
1	Positioning (POSING)	<p>Positions the axis at the specified position using the specified acceleration/deceleration time constant and speed.</p>
2	External Positioning (EX_POSING)	<p>Latches a counter when a latch signal (external positioning signal) is input during positioning (POSING), and positions the axis at a position where it has traveled the external positioning travel distance from that position.</p>
3	Zero Point Return (ZRET)	<p>Returns the system to the machine coordinate system zero point. Eight zero return modes are provided.</p>

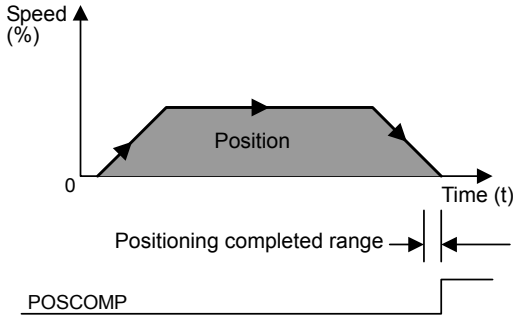
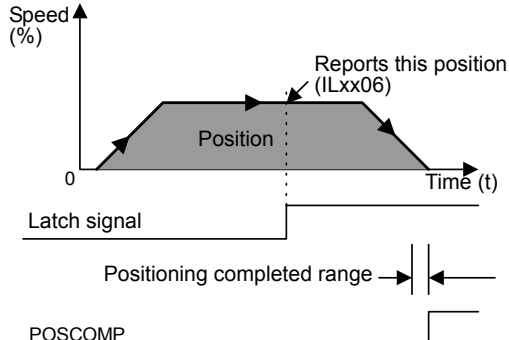
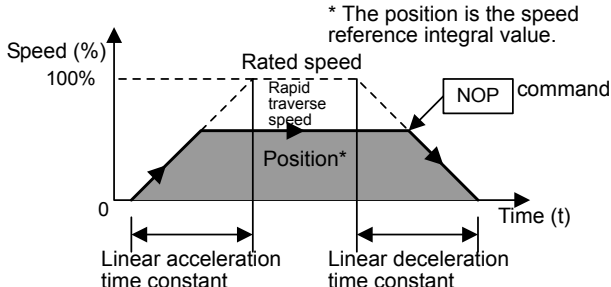
Command	Name	Description
4	Interpolation (INTERPOLATE)	<p>Performs interpolation feeding using the position data distributed from the CPU Module.</p> 
5	Not used.	<p>This command is used by the system. Do not use it in a user program.</p>
6	Interpolation with Position Detection (LATCH)	<p>Latches a counter when a latch signal is input during an interpolation feed operation, and reports the changed latch position to the reference unit system.</p> 
7	Fixed Speed Feed (FEED)	<p>Performs rapid traverse in the infinite length direction at the specified speed and acceleration time.</p> 

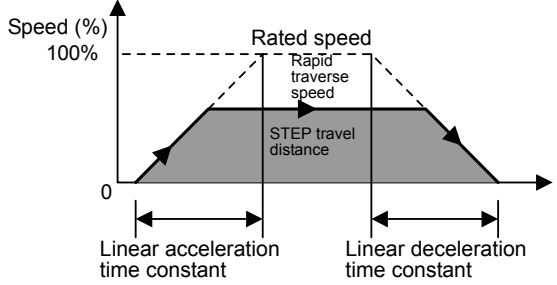
Command	Name	Description
8	Fixed Length Feed (STEP)	<p>Performs STEP travel positioning using the specified direction, speed, and acceleration time constant.</p> 
9	Zero Point Setting (ZSET)	Determines the machine coordinate zero point, and validates the stroke limit check.

11.4.2 Positioning (POSING)

■ Overview

Positions the axis at the position reference position using the specified acceleration/deceleration time constant and the specified rapid traverse speed.

The rapid traverse speed and the position reference value can be changed during operations. When the change in the position reference value is less than the deceleration distance or the reverse direction is used, the system first decelerates to a stop and then is repositioned according to the position reference value.

■ Details

Use the following procedure to perform positioning operations.

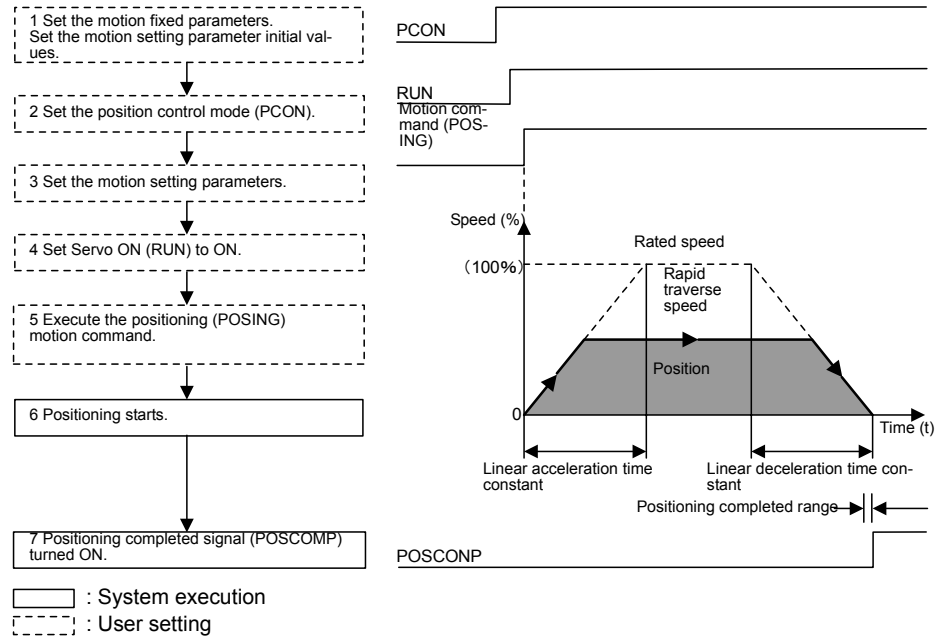

1. Set the initial values for the motion fixed parameters and the motion setting parameters according to the user's machine.

See the setting examples in *6.3 SVA Parameter Details*.

When performing position control using motion commands, be sure to set the following parameters:

- Set “Use (= 1)” in bit 7 (motion command use selection) of motion fixed parameter No. 14 (Additional Function Selections).
 - Set “1 (= Enabled)” in bit 8 (motion command code enabled selection) in the RUN Mode Settings (OWC000) motion setting parameter.
2. Set the Position Control Mode (PCON) (bit 2 of OWC000).
 3. Set the motion setting parameters.
 4. Set Servo ON (RUN) to ON (bit 0 of OWC001).
 5. Set positioning (POSING=1) in the motion command code (OWC020).

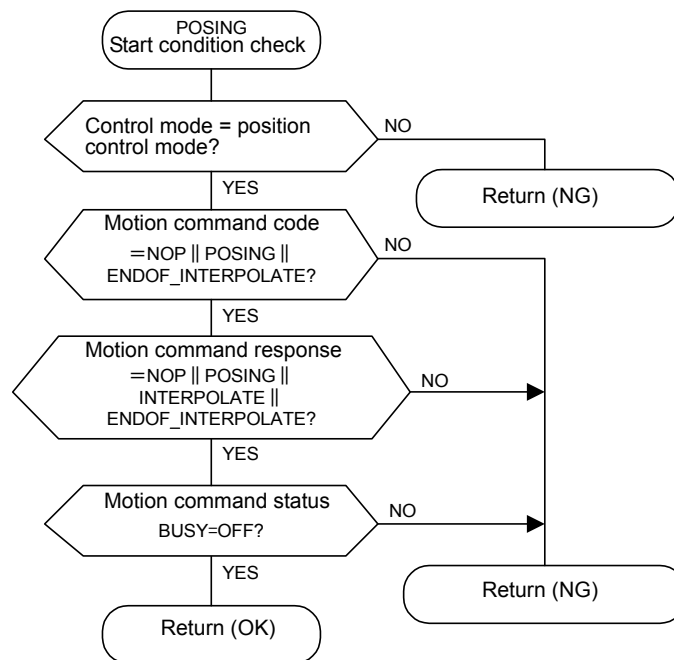

6. Start operation using positioning commands.

Use the specified motion parameters to perform positioning for the axis. Even during positioning, the motion parameter settings can be changed.

The positioning command operations are as follows:

a) Operation Start

Servo ON (bit 0 of OWC001).

Set the positioning (POSING = 1) to motion command code (OWC020).

b) Feed Hold

Set Hold (bit 0 of OWC021) to ON.

At feed hold completion, HOLDL (bit 1 of IWC015) turns ON.

c) Feed Hold Release

Set Hold (bit 1 of OWC021) to OFF. Positioning resumes.

d) Abort

Set Abort (bit 1 of OWC021) to ON, or set NOP (= 0) in the motion command code.

Busy (bit 0 of IWC015) turns ON during abort processing, and turns OFF at completion of the abort.

Note: When the abort has been completed and released (ABORT turns OFF), the following occurs:

- When the Position Reference Type (bit 14 of OWC001) is the absolute position mode (= 0), positioning resumes in the direction of the Position Reference (OLC012).
- When the Position Reference Type (bit 14 of OWC001) is the incremental addition mode (= 1), operations remain stopped until the Reference Position (OLC012) is reset.

- When the axis enters the Positioning Completed Range (OWC00E) after Distribution Completed (bit 2 of IWC015 is ON), the POSCOMP Positioning Completed Signal (bit D of IWC000) turns ON.

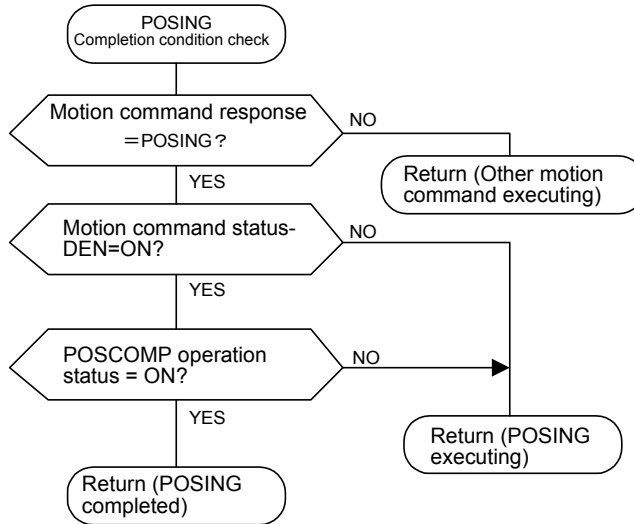

■ User Program Example: Positioning

Example of RUN Operation

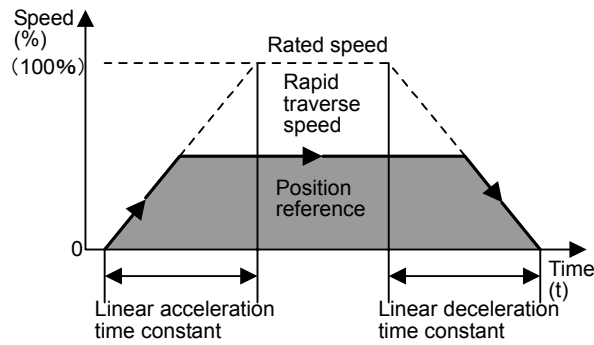

Fig 11.19 Positioning Pattern

Ladder Logic Program Example

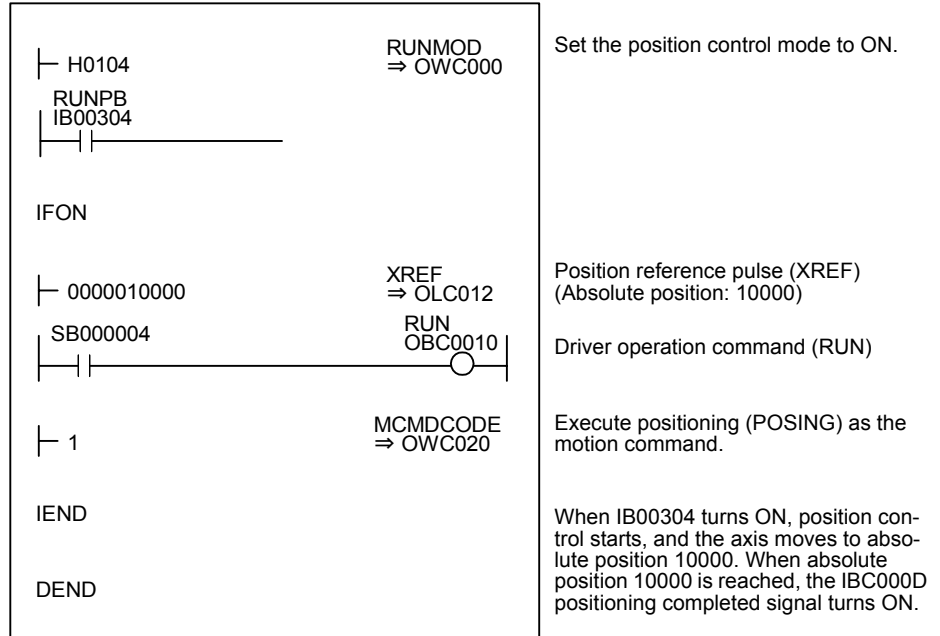

Fig 11.20 Positioning Programming Example (DWG H03)

The example in the above illustration has been greatly simplified. In actual operation, each register can be controlled from the user program.

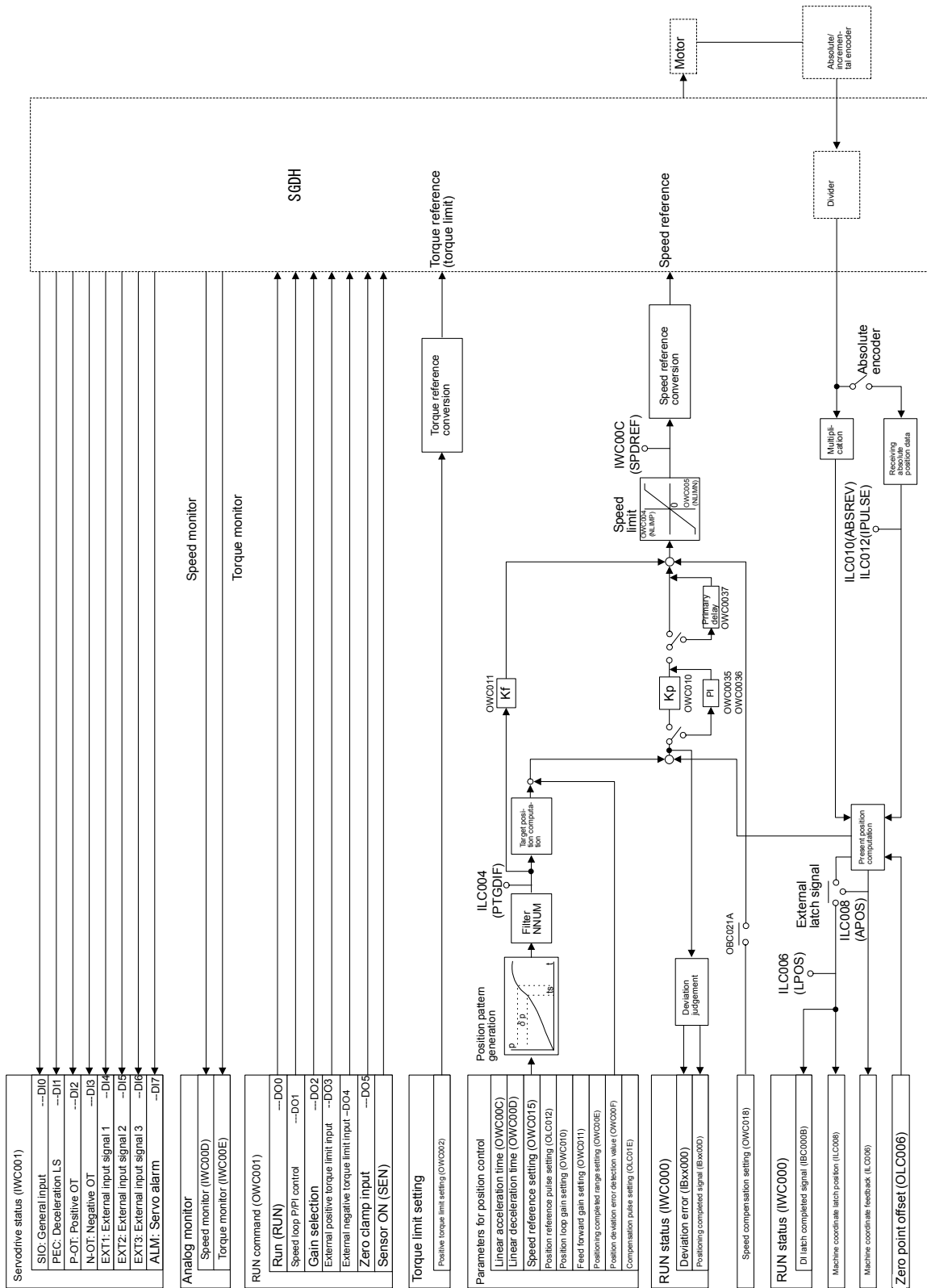

Fig 11.21 MP940 SVA Position Control Mode Block Diagram

11.4.3 External Positioning (EX_POSING)

■ Overview

In the same way as the positioning (POSING) command, the external positioning (EX_POSING) command positions the axis at the position reference position using the specified acceleration/deceleration time constant and the specified rapid traverse speed.

If a latch signal (external positioning signal) is input while at the feed speed, external positioning uses the latch signal to latch the current position, and positions the axis at a position where it has traveled the external positioning travel distance set as a parameter from that position.

The rapid traverse speed and position reference value can be changed even during operation. When the specified external positioning travel distance is less than the deceleration distance, the system first decelerates to a stop and then is repositioned according to the position reference value.

The external positioning travel distance can be changed before the latch signal (external positioning signal) is input.

A specific discrete input (DI input) is used for the latch signal (external positioning signal).

■ Details

Use the following procedure to perform external positioning operations.

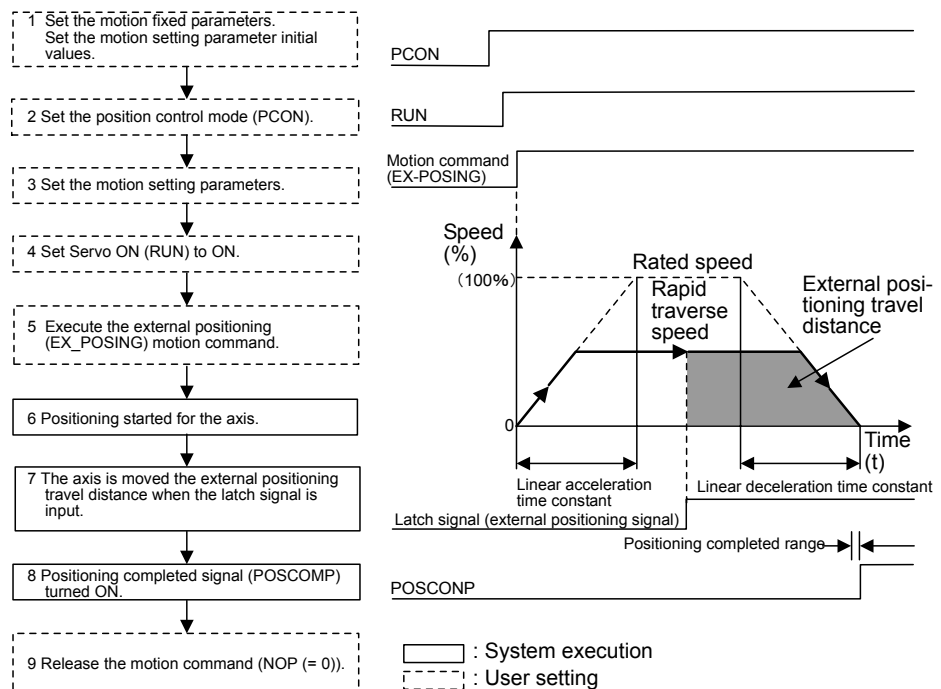

1. Set the initial values for the motion fixed parameters and the motion setting parameters according to the user's machine.
2. Set the Position Control Mode (PCON) (bit 2 of OWC000).

3. Set the motion setting parameters.
4. Set Servo ON (RUN) to ON (bit 0 of OWC001).
5. Set external positioning (EX_POSING=2) in the motion command code (OWC020).
6. Start operation using the external positioning command.

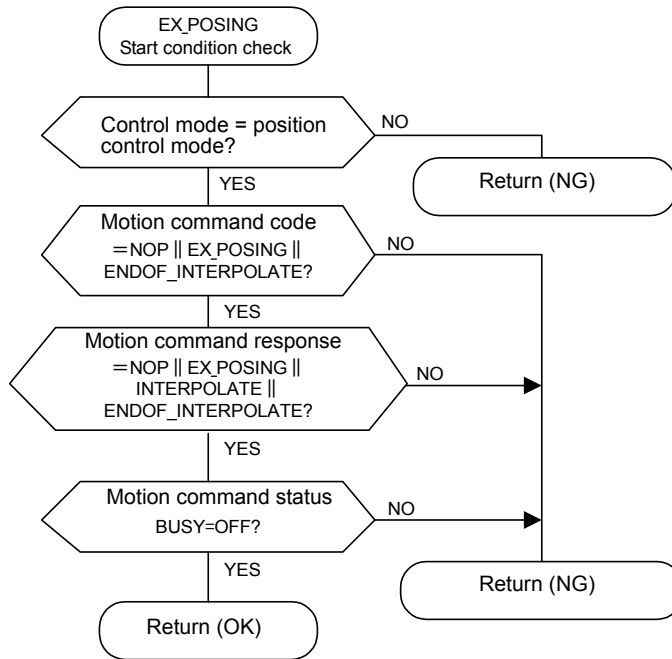

The specified motion parameters are used to position the axis. Even during positioning, the motion parameter setting values can be changed. The external positioning command operations are as follows:

a) Operation Start

Servo ON (bit 0 of OWC001).

Set the external positioning (EX_POSING = 2) to motion command code (OWC020).

b) Feed Hold

Set Hold (bit 0 of OWC021) to ON.

At feed hold completion, HOLDL (bit 1 of IWC015) turns ON.

c) Feed Hold Release

Set Hold (bit 1 of OWC021) to OFF. Positioning resumes.

d) Abort

Set Abort (bit 1 of OWC021) to ON, or set NOP (= 0) in the motion command code.

Busy (bit 0 of IWC015) turns ON during abort processing, and turns OFF at abort completion.

7. When the latch signal is input, the axis moves by the external positioning travel distance (OLC024) and then stops.



At abort completion, operations remain stopped even if the abort is released (ABORT turns OFF) and regardless of whether the Position Reference Type (bit 14 of OWC001) is the absolute position mode (= 0) or the incremental addition mode (= 1).

- When the axis enters the Positioning Completed Range (OWC00E) after Distribution Completed (bit 2 of IWC015 is ON), the POSCOMP Positioning Completed Signal (bit D of IWC000) turns ON.

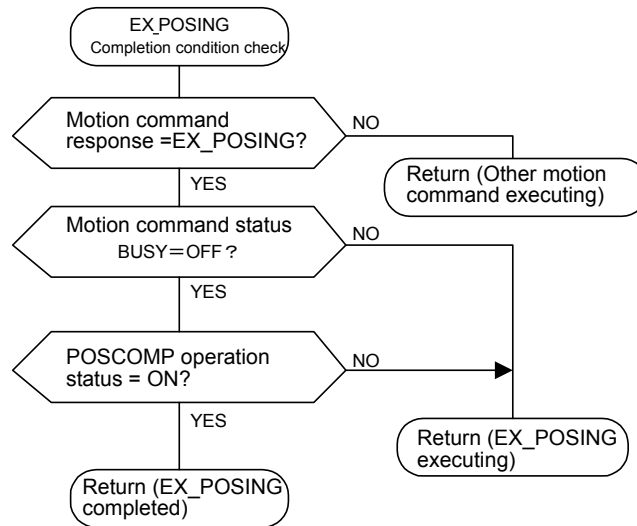

- Once external positioning has been completed, release the external positioning motion command.



External positioning is detected at startup. Therefore, when external positioning has been executed, the motion command must immediately be set to NOP for more than one scan, and external positioning must be reset in a motion command.

■ User Program Example: External Positioning

Example of RUN Operation

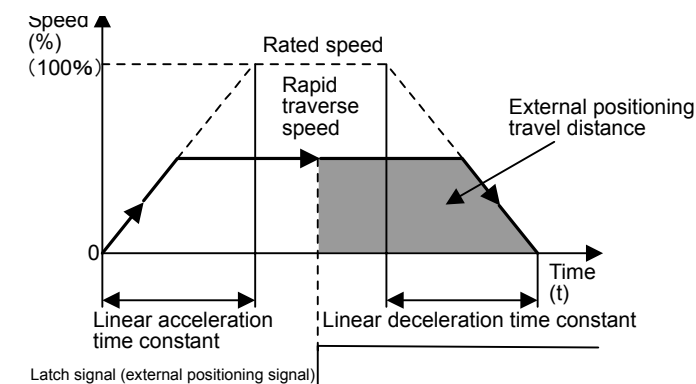

Fig 11.22 Example of an External Positioning Pattern

Ladder Logic Program Example

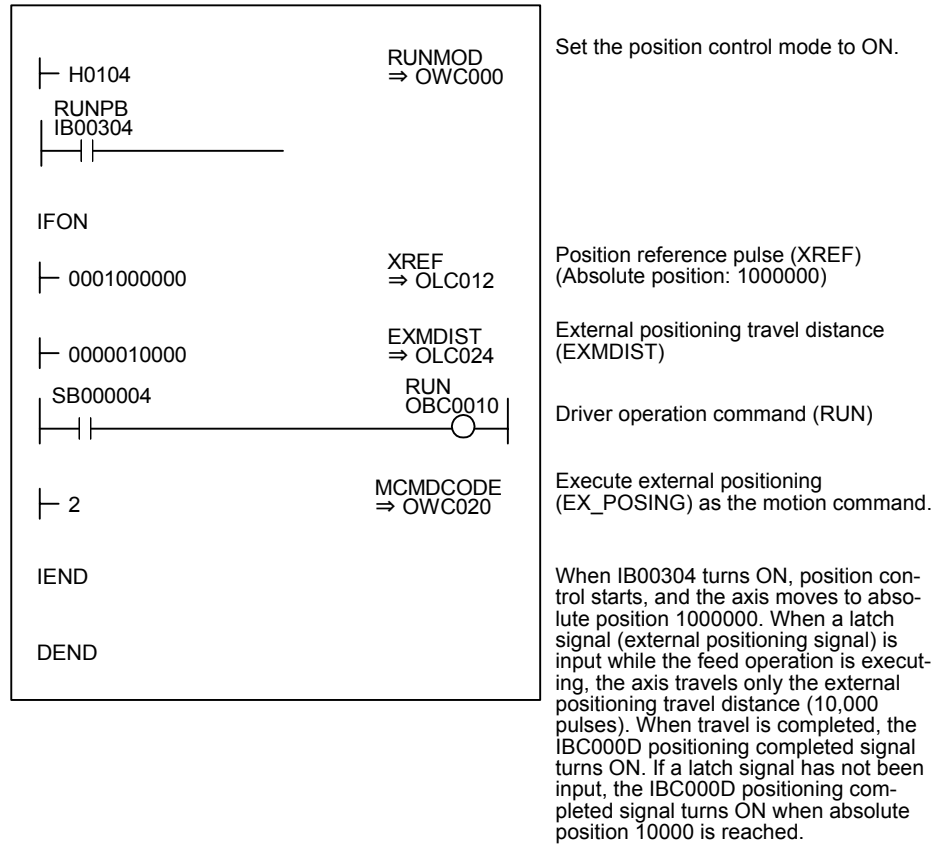

Fig 11.23 External Positioning Programming Example

The example in the above illustration has been greatly simplified. In actual operation, each register can be controlled from the user program.

11.4.4 Zero Point Return (ZRET)

■ Overview

The zero point return operation is used to return to the machine coordinate system zero point.

The machine coordinate system zero point position data is destroyed when the power is turned OFF. Therefore, after turning ON the power, the machine coordinate system zero point must be repositioned. In general, a zero point pulse (Phase-C pulse) and a limit switch showing the zero point area are used to determine the zero point.

There are two zero point return methods. One method uses motion commands, and the other method uses the zero point return mode. Care is required because zero point return operations are different with these two methods.

The method of using motion commands is described below.

For the method of using the zero point return mode, refer to the following section, *Zero Point Return Method*.

■ Zero Point Return Method

The following methods are available with the zero point return (ZRET) motion command.

Zero Point Return Method	Fixed Parameter 31 Setting
DEC1 + Phase-C pulse	0
DEC2 + Phase-C pulse	6
DEC1 + LMT + Phase-C pulse	7
Phase-C pulse	3
DEC1 + ZERO signal	2
DEC2 + ZERO signal	4
DEC1 + LMT + ZERO signal	5
Zero signal	1



- With a limit switch (deceleration limit switch) and a zero point return limit signal, a user program must be created to connect the other external DI signal to the next motion setting parameters.

- Limit Switch Signal*: OBC001F
- Reverse Limit Signal for Zero Point Return: OBC021C
- Forward Limit Signal for Zero Point Return: OBC021D

* Whether a DI signal or OBC001F is used as the limit switch signal is set in the bit 2 in motion fixed parameter No. 14 (Additional Function Selections).

- A limit switch (deceleration limit switch) signal's polarity can be reversed using the setting of bit 10 (Deceleration Limit Switch Inversion Selection) in motion fixed parameter No. 17 (Motion Controller Function Selection Flags). The default is 0 (do not reverse).

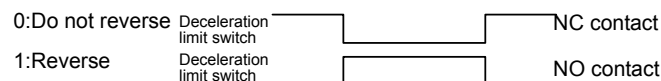

- Refer to 11.2.5 *Zero Point Return Mode* for details.
- The zero point return method is set in b0 to b7 of fixed parameter No. 31 (Zero Point Return Method).

Details on each method are given next.

■ DEC1 + Phase-C Pulse

This method is used to perform zero point return using a limit switch (deceleration limit switch) and a zero point signal (Phase-C pulse) by rapid traverse using linear acceleration/deceleration (with a dog width).

The limit switch is used with a mechanical configuration such as the one shown in the following illustration.

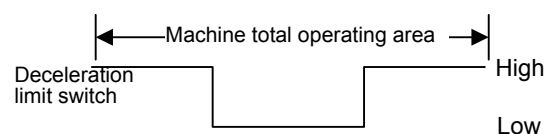

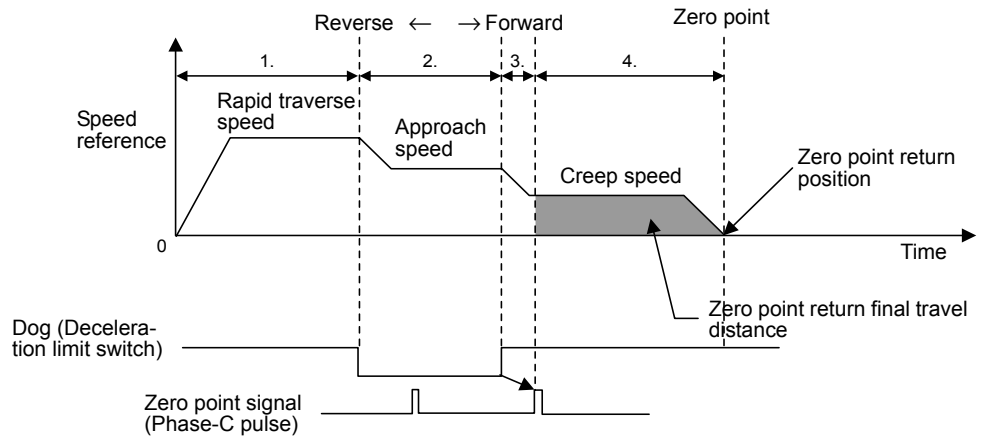

1. The axis travels at rapid traverse speed in the direction specified in the motion setting parameter (OBC0009).
2. The axis decelerates to approach speed at the falling edge of the dog (deceleration limit switch) signal.
3. The axis decelerates to creep speed at the rising edge of the dog (deceleration limit switch) signal.
4. When the dog is high, the axis stops after traveling only the zero point return final travel distance (OLC02A) from the initial zero point signal (Phase-C pulse), and that position will be the machine coordinate system zero point.

IMPORTANT

Automatic return is not performed with this zero point return method. Where zero point return to a position is not possible, use a manual operation to return to the zero point.

■ DEC2 + Phase-C Pulse

This method is used to perform zero point return using a limit switch (deceleration limit switch) and a zero point signal (Phase-C pulse) by rapid traverse using linear acceleration/deceleration (without a dog width).

The method is used when limit switches are used in the following machine configuration.

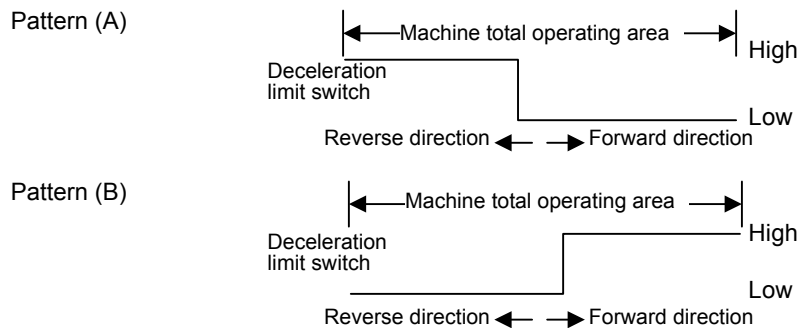



- With this method, the axis recognizes the machine position by the deceleration limit switch ON/OFF status, and automatically performs a return operation. Be sure to perform zero point return under the same conditions.
- With pattern (B), set the deceleration limit switch inversion selection (bit 10) of motion fixed parameter No. 17 to ON.

Zero Point Return Operation Started with the Dog (Deceleration Limit Switch) Signal in the High Area

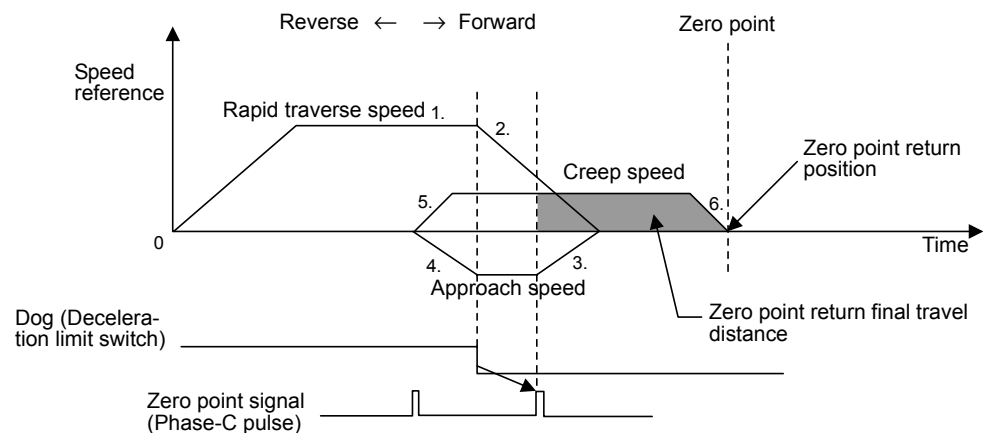

1. The axis travels at rapid traverse speed in the forward direction.
2. The axis decelerates at the falling edge of the dog (deceleration limit switch) signal.
3. The axis travels at approach speed in the reverse direction.
4. The axis decelerates at the rising edge of the dog (deceleration limit switch) signal.
5. The axis travels at creep speed in the forward direction.
6. After the falling edge of the dog (deceleration limit switch) is detected, the axis stops after traveling only the zero point return final travel distance (OLC02A) from the initial zero point signal, and that position will be the machine coordinate system zero point.

Zero Point Return Operation Started with the Dog (Deceleration Limit Switch) Signal in the Low Area

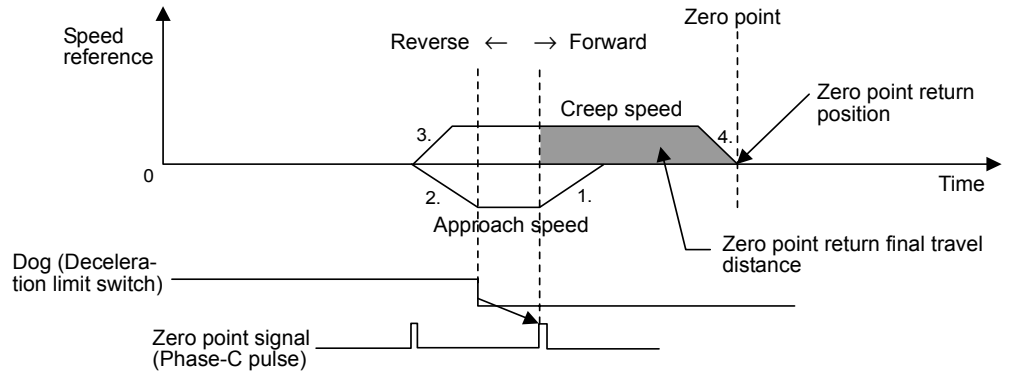

1. The axis travels at creep speed in the forward direction.
2. The axis decelerates at the rising edge of the dog (deceleration limit switch) signal.
3. The axis travels at approach speed in the reverse direction.
4. After the falling edge of the dog (deceleration limit switch) is detected, the axis stops after traveling only the zero point return final travel distance (OLC02A) from the initial zero point signal, and that position will be the machine coordinate system zero point.

■ DEC1 + LMT + Phase-C Pulse

This method is used to perform zero point return using a limit switch (deceleration limit switch), a zero point return limit signal, and a zero point signal (Phase-C pulse) by rapid traverse using linear acceleration/deceleration (with a dog width).

The limit switch (deceleration limit switch) and the zero point return limit signal are used with a mechanical configuration such as the one shown in the following illustration.

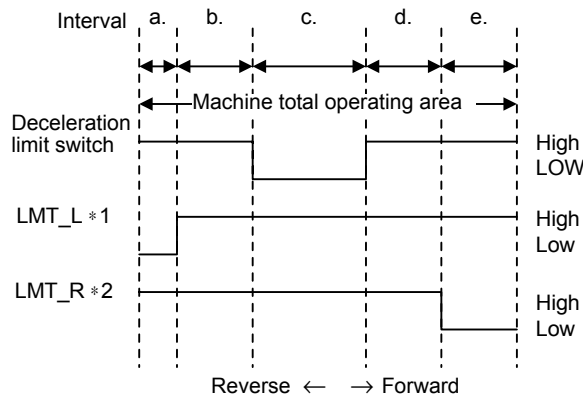

* 1. Zero point return reverse limit signal (OBC021C)

* 2. Zero point return forward limit signal (OBC021D)

Zero Point Return Operation Started and Interval (a) Used

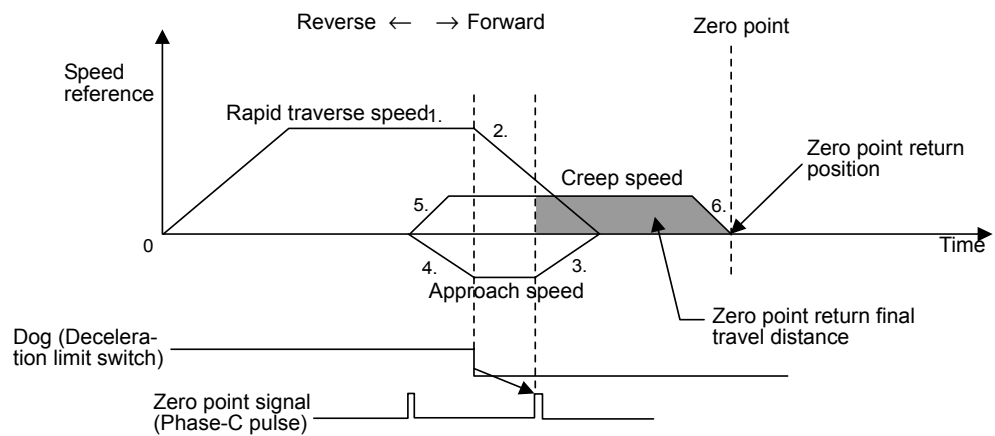

1. The axis travels at rapid traverse speed in the forward direction.
2. The axis decelerates at the falling edge of the dog (deceleration limit switch) signal.
3. The axis travels at approach speed in the reverse direction.
4. The axis decelerates at the rising edge of the dog (deceleration limit switch) signal.
5. The axis travels at creep speed in the forward direction.
6. After the falling edge of the dog (deceleration limit switch) is detected, the axis stops after traveling only the zero point return final travel distance (OLC02A) from the initial zero point signal, and that position will be the machine coordinate system zero point.

Zero Point Return Operation Started and Interval (b) Used

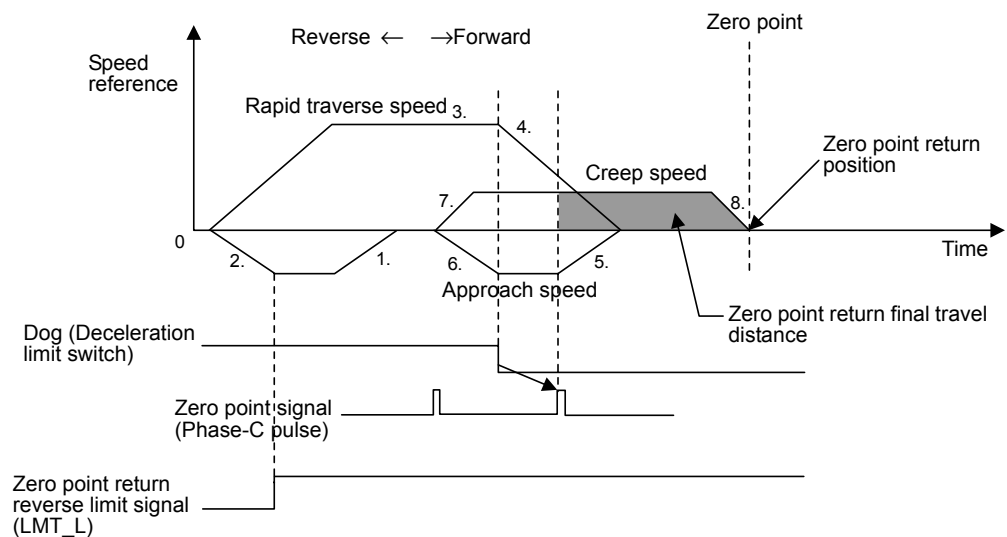

1. The axis travels at approach speed in the reverse direction.
2. The axis decelerates at the falling edge of the zero point return reverse limit signal (LMT_L).

3. The axis travels at rapid traverse speed in the forward direction.
4. The axis decelerates at the falling edge of the dog (deceleration limit switch) signal.
5. The axis travels at approach speed in the reverse direction.
6. The axis decelerates at the rising edge of the dog (deceleration limit switch) signal.
7. The axis travels at creep speed in the forward direction.
8. After the falling edge of the dog (deceleration limit switch) is detected, the axis stops after traveling only the zero point return final travel distance (OLC02A) from the initial zero point signal, and that position will be the machine coordinate system zero point.

Zero Point Return Operation Started and Interval (c) Used

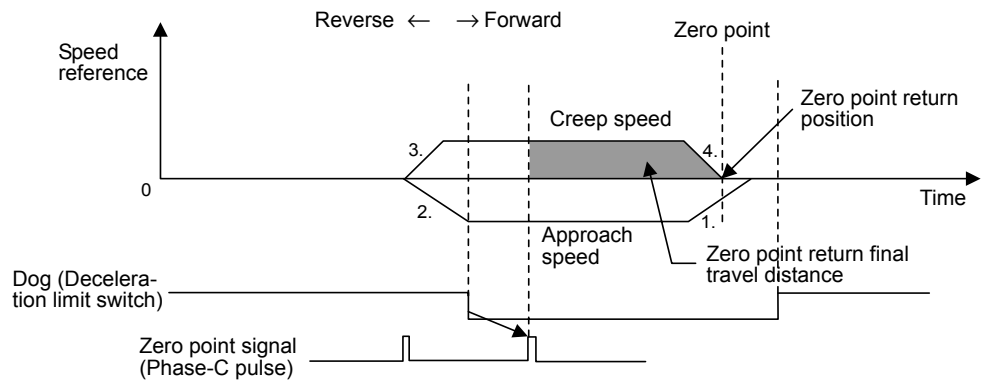

1. The axis travels at approach speed in the reverse direction.
2. The axis decelerates at the rising edge of the dog (deceleration limit switch) signal.
3. The axis travels at creep speed in the forward direction.
4. After the falling edge of the dog (deceleration limit switch) is detected, the axis stops after traveling only the zero point return final travel distance (OLC02A) from the initial zero point signal, and that position will be the machine coordinate system zero point.

Zero Point Return Operation Started and Intervals (d) & (e) Used

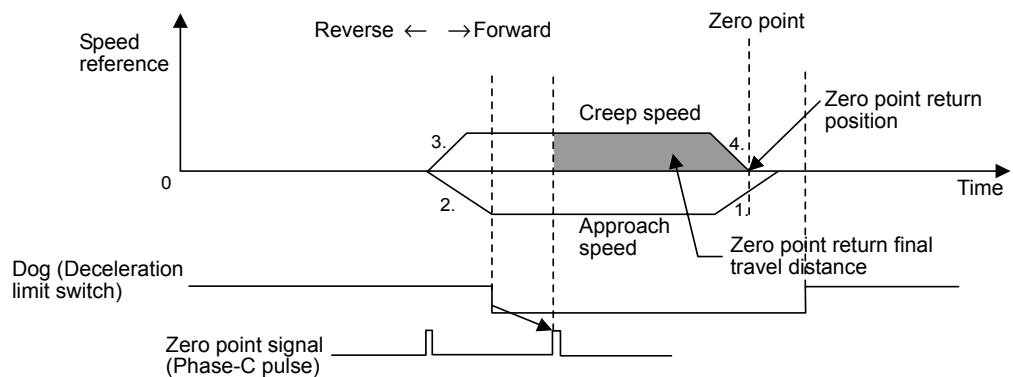

1. The axis travels at approach speed in the reverse direction.
2. The axis decelerates at the rising edge of the dog (deceleration limit switch) signal.

3. The axis travels at creep speed in the forward direction.
4. After the falling edge of the dog (deceleration limit switch) is detected, the axis stops after traveling only the zero point return final travel distance from the initial zero point signal, and that position will be the machine coordinate system zero point.

■ Phase-C Pulse

This method is used to perform zero point return using only a zero point signal (Phase-C pulse) by rapid traverse using linear acceleration/deceleration.

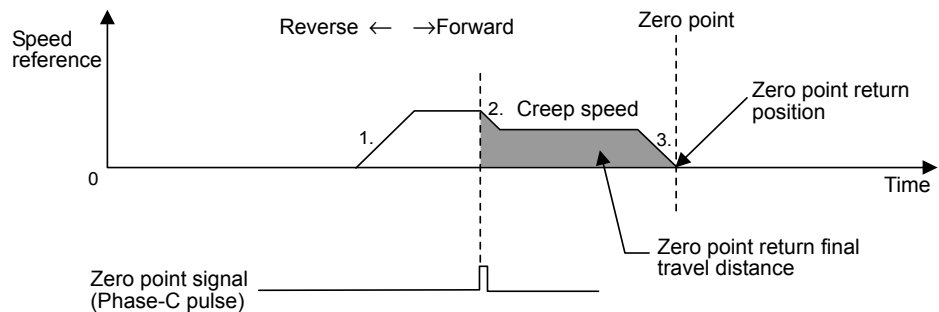

1. The axis travels at approach speed in the direction specified in the motion setting servo parameter (OBC0009).
2. The axis decelerates to creep speed after detecting the initial zero point signal.
3. The axis stops after traveling only the zero point return final travel distance from the initial zero point signal, and that position will be the machine coordinate system zero point.

■ DEC1 + ZERO Signal

Zero point return is performed using a ZERO signal (DI signal) in place of the Phase-C pulse used in the DEC1 + Phase-C Pulse described previously.

For details, see *DEC1 + Phase-C Pulse* described previously.

■ DEC2 + ZERO Signal Method

Zero point return is performed using a ZERO signal (DI signal) in place of the Phase-C pulse used in the DEC2 + Phase-C Pulse described above.

For details, see *DEC2 + Phase-C Pulse*.

■ DEC1 + CMT + ZERO Signal Method

Zero point return is performed using a ZERO signal (DI signal) in place of the Phase-C pulse used in the DEC1 + CMT + Phase-C Pulse described above.

For details, see *DEC1 + CMT + Phase-C Pulse*.

■ ZERO Signal Method

Zero point return is performed using a ZERO signal (DI signal) in place of the Phase-C pulse used in the Phase-C Pulse described above.

For details, see Phase-C Pulse.

IMPORTANT

The EXT2 signal of the SERVOPACK is used for the ZERO signal (DI signal).

■ Example of the Zero Point Return Operations

Use the following procedure to perform zero point return operations.

The following illustration shows an example of the DEC1 + Phase-C pulse method.

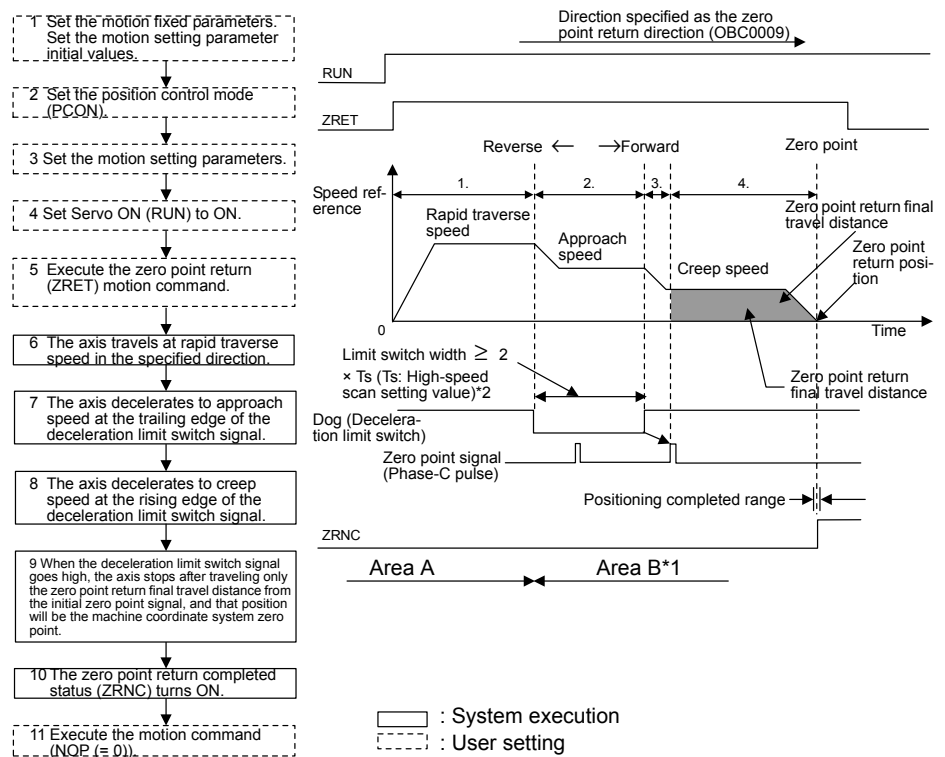

1. Set the initial values for the motion fixed parameters and the motion setting parameters according to the user's machine.
2. Set the Position Control Mode (PCON) (bit 2 of OWC000).
3. Set the motion setting parameter to be used with zero point return (ZRET).
4. Set Servo ON (RUN) to ON (bit 0 of OWC001).
5. Set zero point return (ZRET = 3) in the motion command code (OWC020).
6. Start operation using the zero point return (ZRET).

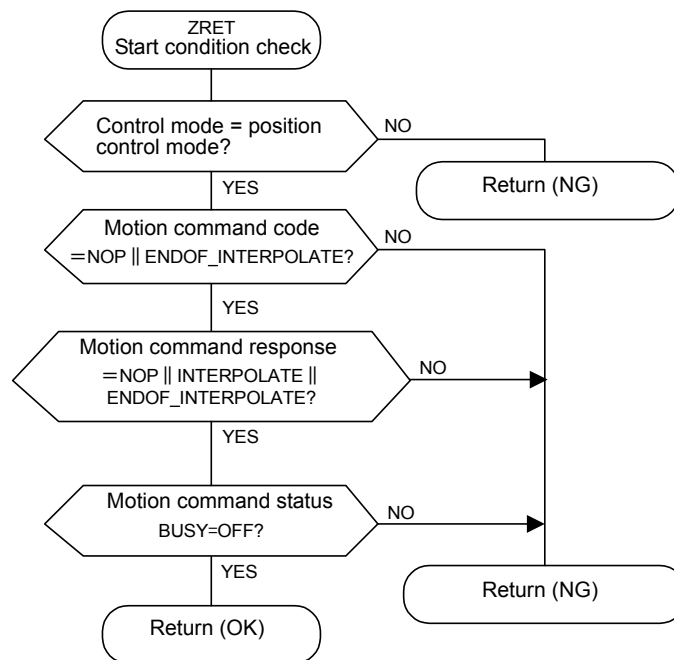

The axis travels at rapid traverse speed in the direction specified by the zero point return direction selection (OBC0009).

The motion parameter setting values cannot be changed during a zero point return operation.

The zero point return command operations are as follows:

a) Operation Start

Servo ON (bit 0 of OWC001).

Set the zero point return (ZRET = 3) to motion command code (OWC020).

b) Feed Hold

Not possible.

c) Abort

Set Abort (bit 1 of OWC021) to ON, or set NOP (= 0) in the motion command code.

Busy (bit 0 of IWC015) turns ON during abort processing, and turns OFF at abort completion.

Note: Even when the abort is completed and the abort is released (ABORT turns OFF), operations remain stopped.

7. The axis decelerates to approach speed at the falling edge of the dog (deceleration limit switch) signal.
8. The axis decelerates to creep speed at the rising edge of the dog (deceleration limit switch) signal.
9. When the dog goes high, the axis stops after traveling only the zero point return final travel distance (OLC02A) from the initial zero point signal (Phase-C pulse), and that position will be the machine coordinate system zero point.

A zero point position offset value can also be set. (If Machine Coordinate System Zero

Point Offset OLC006 is set in advance to 100, the position data will be 100.)

10. The zero point return operation is completed when the axis enters the Positioning Completed Range (OWC00E) after Distribution Completed (bit 2 of IWC015 is ON). When the zero point return operation is completed, the ZRNC Zero Point Return Completed (bit 6 of IWC015) turns ON.

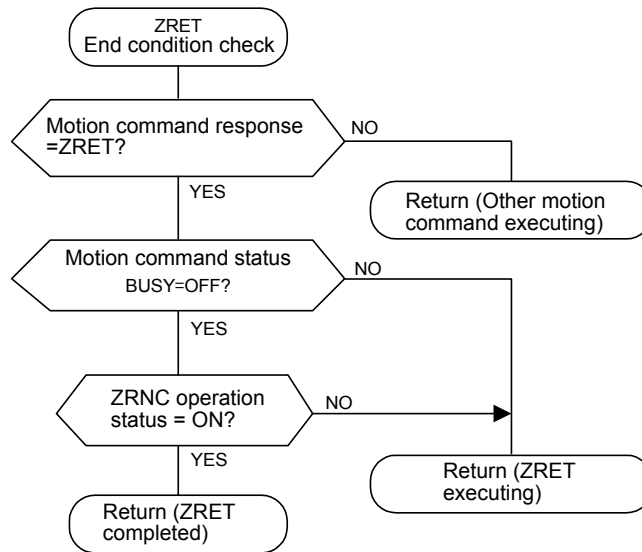

11. After checking that the ZRNC Zero Point Completed (bit 6 of IWC015) is ON, set NOP (= 0) in the motion command code (OWC020).

IMPORTANT

- If the machine is in Area B after the power is turned ON, the return cannot be performed correctly. Be sure to move the machine back to Area A before performing a return.
- The deceleration limit switch width must be at least twice that of the high-speed scan setting value. The criteria for the deceleration limit switch width (L) can be calculated using the formula shown below.

- T_s (s) = High-speed scan set value (ms)/1000

- F (m/s) = $K \times \{NR \times n \times FBppr\} / 60$

f : 100% speed (m/s)

K : Weight of 1 pulse (m/pulse)

NR : Rated rotation speed (r/min)

$FBppr$: Feedback pulse resolution (ppr)

n : Pulse magnification (1, 2, or 4)

- t (s) = Linear acceleration/deceleration time (s)

- α (m/s²) = f/t

If α = acceleration/deceleration time constant (m/s²), the following equation applies.

$$L = 1/2 \times \alpha (2 \times T_s)^2 = 2\alpha T_s^2$$

- When a short distance is set for the zero point return final travel distance, the axis returns to the zero point after the zero point has been passed once.

User Program Example: Zero Point Return

- Example of RUN Operation

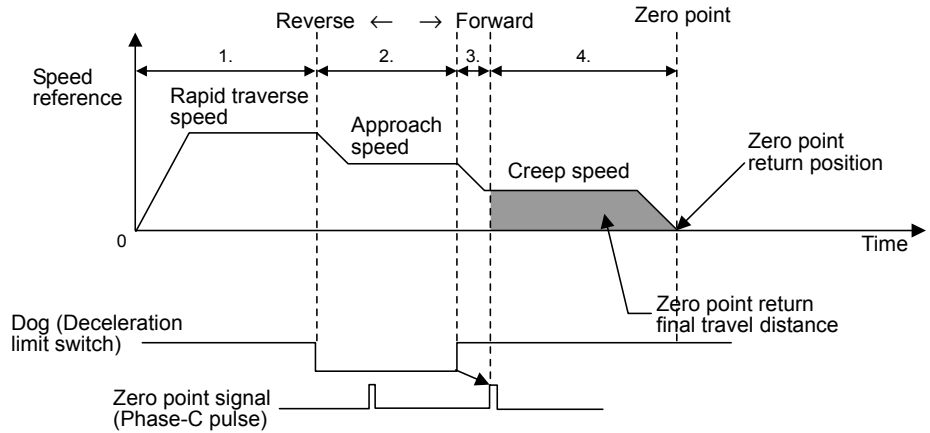

Fig 11.24 Example of a Zero Point Pattern (DEC1 + Phase-C Pulse Signal Method)

- Ladder Logic Program Example

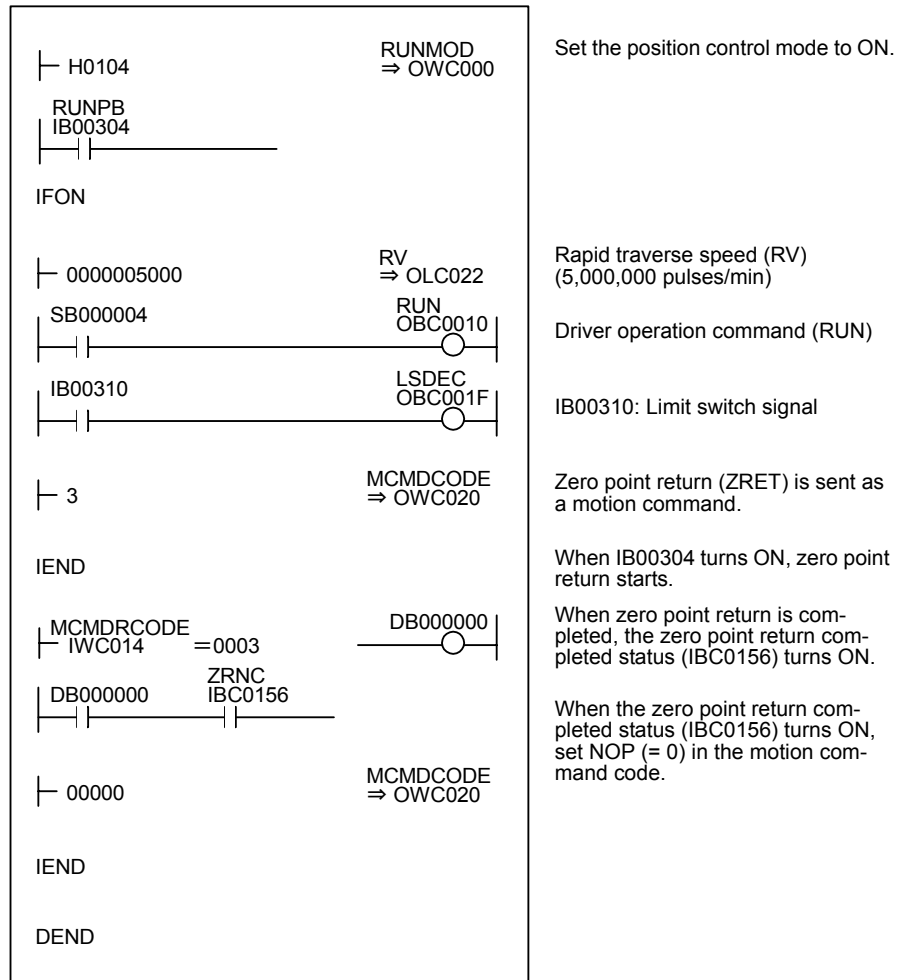

Fig 11.25 Zero Point Return Programming Example (DWG H03)

The example in the above illustration has been greatly simplified. In actual operation, each register can be controlled from the user program.

11.4.5 Interpolation (INTERPOLATE)

■ Overview

This command performs interpolation feeding using the position data distributed from the CPU Module.

■ Details

Use the following procedure to perform interpolation feed operations.

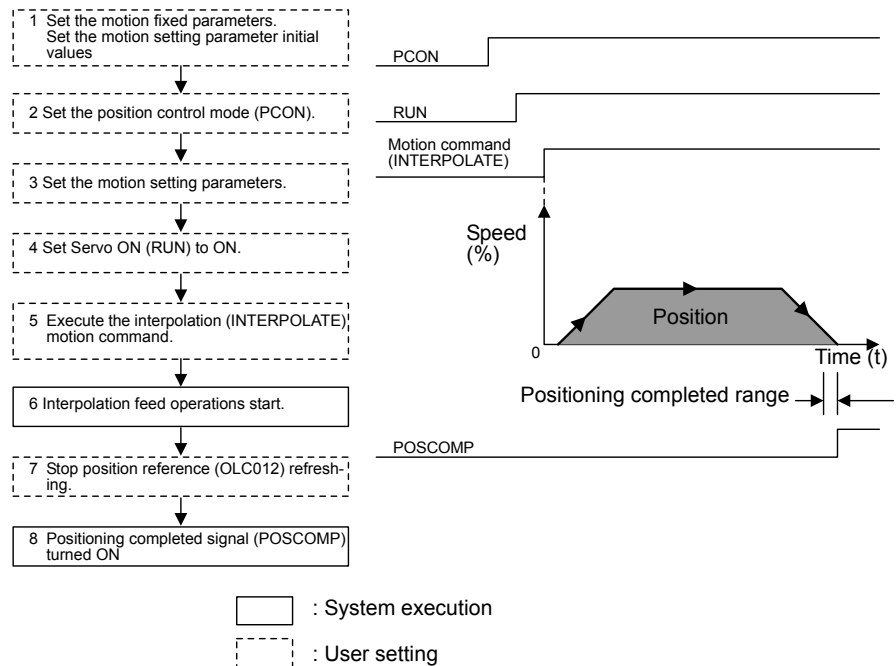

1. Set the initial values for the motion fixed parameters and the motion setting parameters according to the user's machine.
2. Set the Position Control Mode (PCON) (bit 2 of OWC000).
3. Set the Position Reference Setting (OLC012).

If required, set any motion setting parameters to use with interpolation (INTERPOLATE), such as the Filter Constant (OWC014).

4. Set Servo ON (RUN) to ON (bit 0 of OWC001).
5. Set interpolation (INTERPOLATE=4) in the motion command code (OWC020).

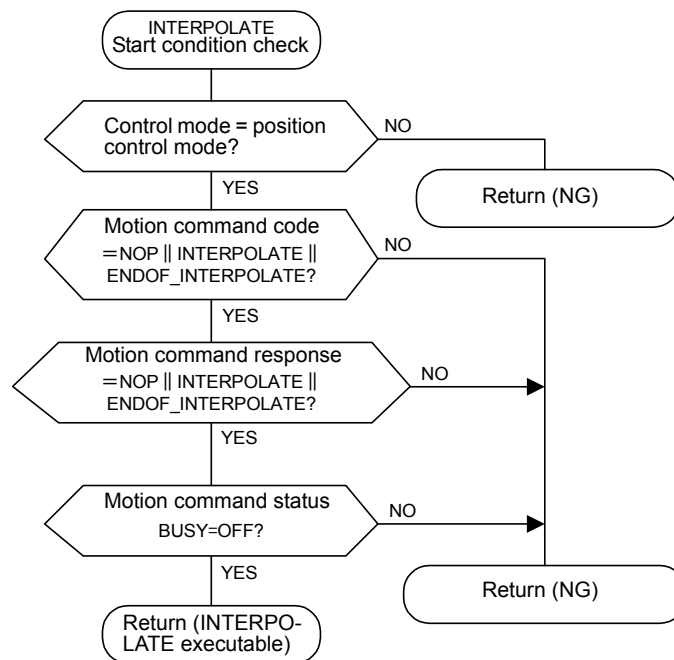

6. When interpolation (INTERPOLATE) is set as the motion command, the axis performs interpolation feed using the specified motion parameter.
7. Stop refreshing the position reference (OLC012).
8. When the axis enters the Positioning Completed Range (OWC00E) after Distribution Completed (bit 2 of IWC015 is ON), the POSCOMP Positioning Completed Signal (bit D of IWC000) turns ON.

11.4.6 Interpolation with Position Detection (LATCH)

■ Overview

In the same way as for an interpolation feeding, the latch signal is used to latch the current position counter while the interpolation feed is being executed, and reports the changed latch position converted to the reference unit system.

A specific discrete input (DI input) is used for the latch signal.

■ Details

For details on interpolation operations, refer to *11.4.5 Interpolation (INTERPOLATE)*.

IMPORTANT

When latching is performed again after current position counter latching has been executed once by the latch signal, first set the motion command to NOP for 1 scan or more, and then execute the LATCH command.

Settings will be set as follows by the fixed parameter 13 (DI latch detection signal selection): 0: EXT3; 1: Phase C.

11.4.7 Fixed Speed Feed (FEED)

■ Overview

This command performs rapid traverse in the infinite length direction using the specified acceleration/deceleration time constant and the specified rapid traverse speed.

The rapid traverse speed can be changed during operations.

The axis decelerates to a stop when NOP (= 0) is set in the motion command code (OWC020).

■ Details

Use the following procedure to perform fixed speed feed operations.

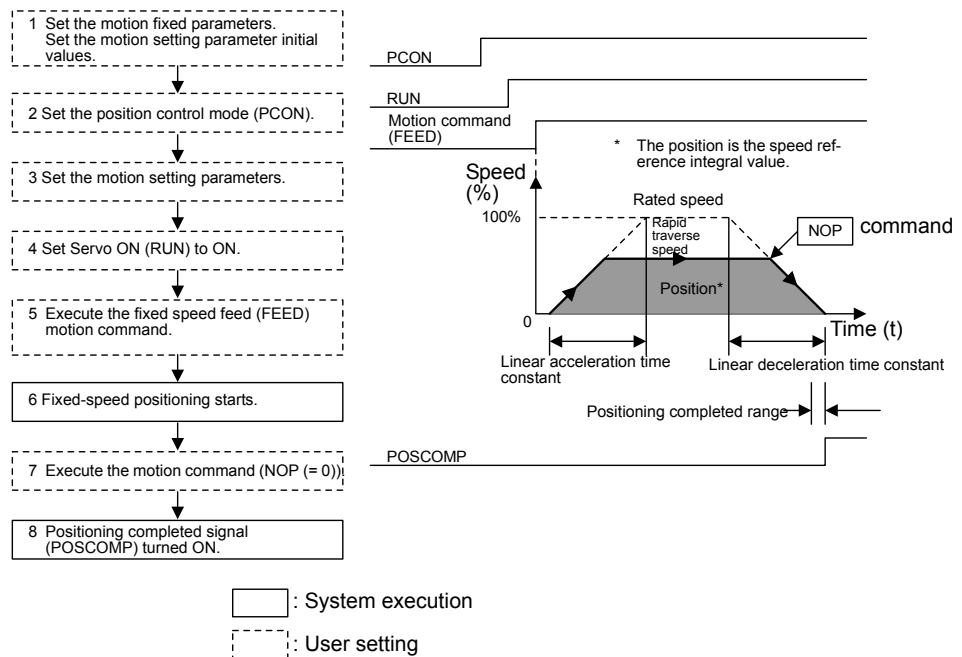

1. Set the initial values for the motion fixed parameters and the motion setting parameters according to the user's machine.
2. Set the Position Control Mode (PCON) (bit 2 of OWC000).
3. Set the Rapid Traverse Speed (OLC022 or OWC015).
Set the motion setting parameter to be used with fixed speed feed (FEED).
4. Set Servo ON (RUN) to ON (bit 0 of OWC001).
5. Set fixed speed feed (FEED=7) in the motion command code (OWC020).
6. Start operation using the fixed speed feed (FEED).

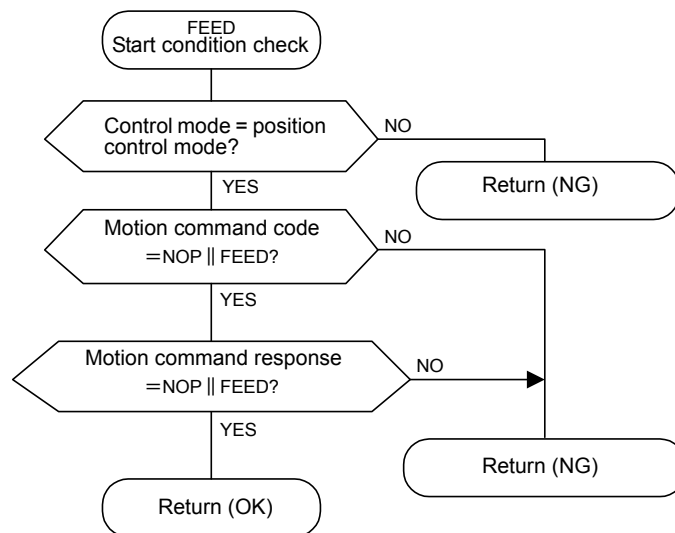

The axis performs fixed speed feed using the specified motion parameter.

Fixed speed feed cannot be temporarily stopped.

7. To stop (abort) fixed speed feed, set NOP (= 0) in the motion command code (OWC020).
8. When the axis enters the Positioning Completed Range (OWC00E) after Distribution Completed (bit 2 of IWC015 is ON), the POSCOMP Positioning Completed Signal (bit D of IWC000) turns ON.

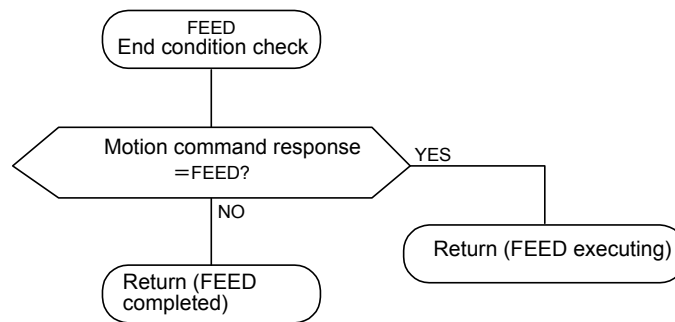

■ User Program Example: Fixed Speed Feed

Example of RUN Operation

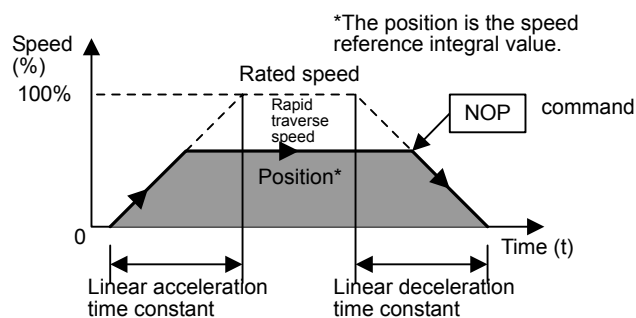

Fig 11.26 Example of a Fixed Speed Feed Pattern

Ladder Logic Program Example

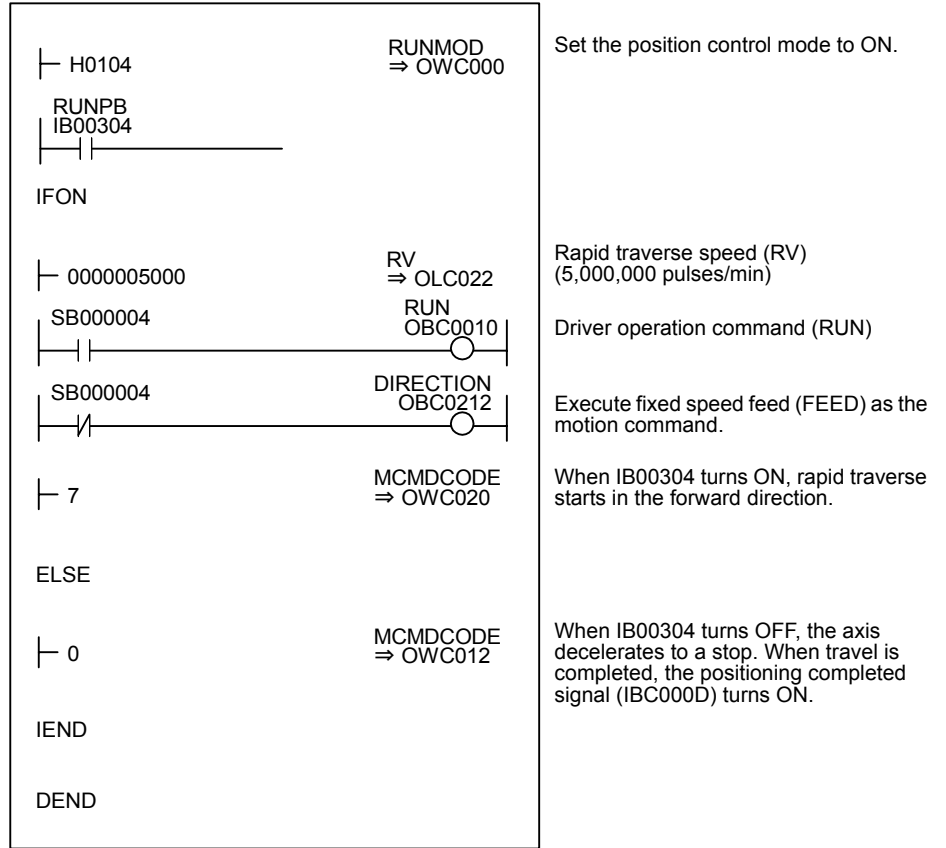

Fig 11.27 Fixed Speed Feed Programming Example (DWG H03)

The example in the above illustration has been greatly simplified. In actual operation, each register can be controlled from the user program.

11.4.8 Fixed Length Feed (STEP)

■ Overview

This command positions the axis at rapid traverse speed in the specified direction for only the specified travel distance (STEP travel distance) using the specified acceleration/deceleration time constant.

The rapid traverse speed can be changed during operations.

When you change the travel distance during operations, the changed value will be incorporated when the next fixed length feed (STEP) is executed.

■ Details

Use the following procedure to perform fixed length feed operations.

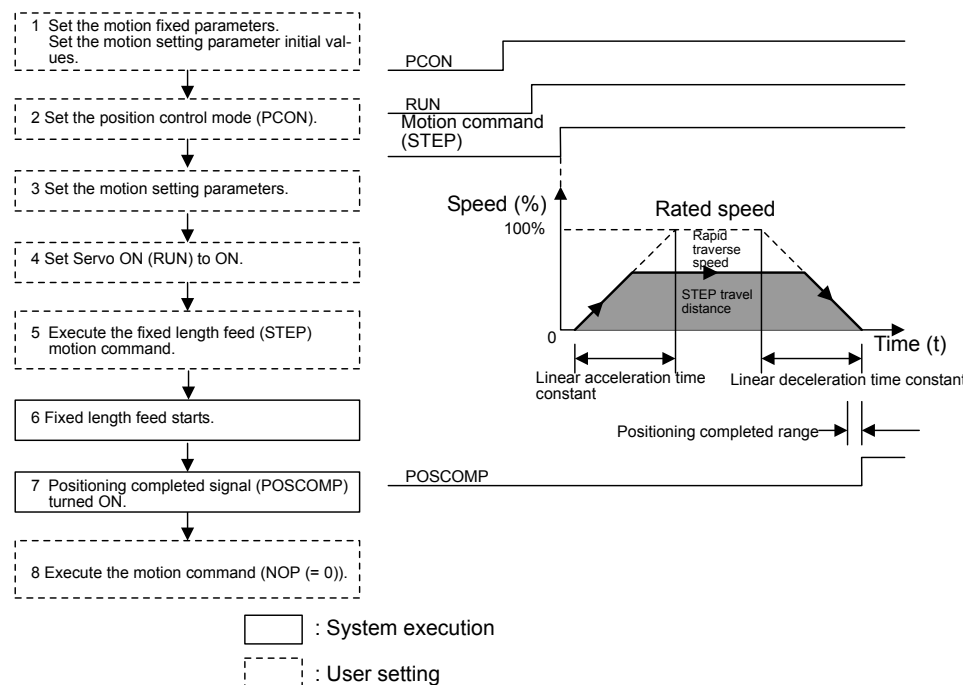

1. Set the initial values for the motion fixed parameters and the motion setting parameters according to the user's machine.
2. Set the Position Control Mode (PCON) (bit 2 of OWC000).
3. Set the Step travel distance (OLC028) and the Rapid Traverse Speed (OLC022 or OWC015).
Set the motion setting parameter to be used with fixed length feed (STEP).
4. Set Servo ON (RUN) to ON (bit 0 of OWC001).
5. Set fixed length feed (STEP = 8) to the motion command code (OWC020).
6. Start operation using the fixed length feed (STEP).

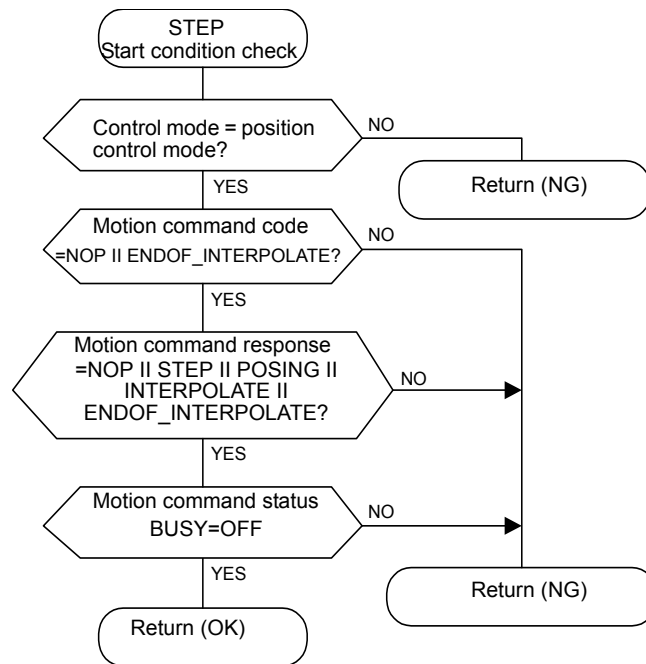

The axis performs positioning using the specified motion parameter. Even during fixed length feed operations, the motion parameter settings can be changed.

The fixed length feed command operations are as follows:

a) Operation Start

Set Servo ON (bit 0 of OWC001) to ON.

Set fixed length feed (STEP=8) in the motion command code (OWC020).

b) Feed Hold

Set Hold (bit 0 of OWC021) to ON.

At feed hold completion, HOLDL (bit 1 of IWC015) turns ON.

c) Feed Hold Release

Set Hold (bit 1 of OWC021) to OFF. Positioning resumes.

d) Abort

Set Abort (bit 1 of OWC021) to ON, or set NOP (= 0) in the motion command code.

Note: Even when the abort is completed and the abort is released (ABORT turns OFF), operations remain stopped.

7. When the axis enters the Positioning Completed Range (OWC00E) after Distribution Completed (bit 2 of IWC015 is ON), the POSCOMP Positioning Completed Signal (bit D of IWC000) turns ON.

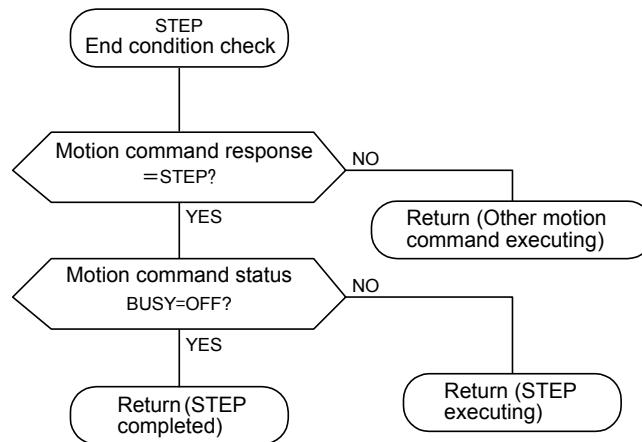

8. Once positioning has been completed, the fixed length feed motion command is released.

Note: Fixed length feed is detected at the rising edge. Therefore, when fixed length feed has been executed, the motion command must be set to NOP for 1 scan or more, and fixed length feed must be reset as the motion command.

■ User Program Example: Fixed Length Feed

Example of RUN Operation

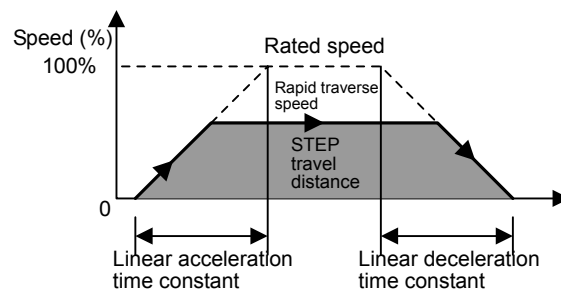

Fig 11.28 Example of a Fixed Length Feed Pattern

■ Overview

When the zero point setting is executed, the current position will be the machine coordinate system zero point. Therefore, the zero point can be set without performing a zero point return operation.

When a stored stroke limit is used, be sure to execute a zero point return operation or a zero point setting.

■ Details

Use the following procedure to set the zero point.

1. Move the machine to the zero point using fixed speed feed, fixed length feed, or manual operation.
2. Set the Position Control Mode (PCON) (bit 2 of OWC000).

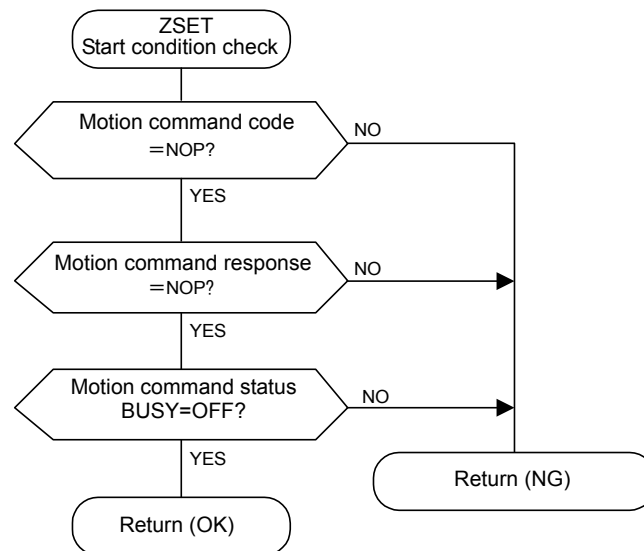

Note: Set “Use (= 1)” in bit 7 (motion command use selection) of motion fixed parameter No. 14 (Additional Function Selections). Set “1 (= Enabled)” in bit 8 (motion command code enabled selection) of the RUN Mode Selection (OWC000) motion setting parameter.

3. Set the zero point setting (ZSET = 9) in the motion command code (OWC020).

Note: Servo ON (bit 0 of OWC001) may be either ON or OFF. The zero point setting (ZRET) command cannot be executed when the axis is traveling if motion fixed parameter No. 3 (Encoder Selection) is set in the absolute encoder (= 1) and bit 5 (axis selection) of motion fixed parameter No. 17 (Motion Controller Function Selection Flags) is set to “infinite length axis” (= 1).

4. When the zero point setting has been completed, Zero Point Setting Completed (bit 3 of IWC015) and the Zero Point Return Completed (bit 6 of IWC015) turn ON.

A Dimensions



This appendix shows external dimensions of the MP940 Module.

A.1 External of MP940 Module -----A-2
A.2 Dimensions of MP940D -----A-2

A.1 External of MP940 Module

Description: MP940

Model: JEPMC-MC400

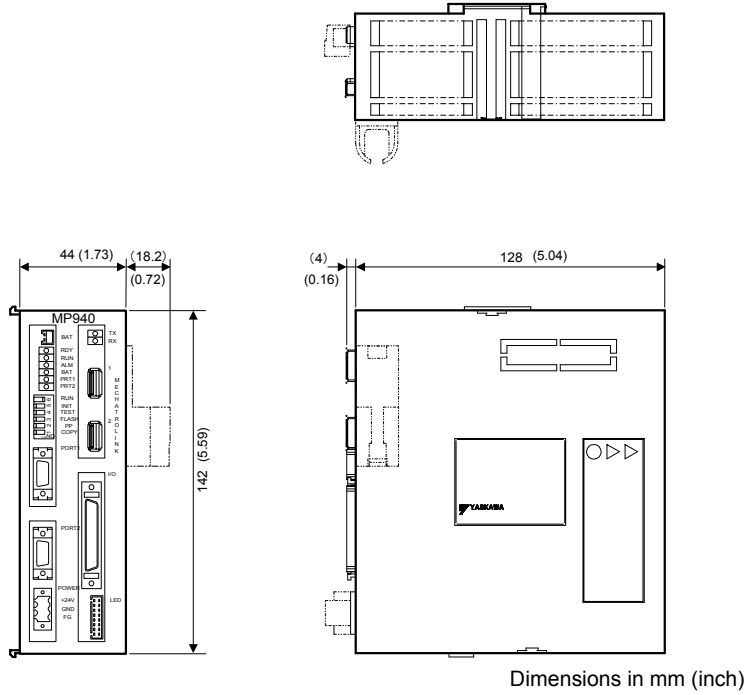

A.2 Dimensions of MP940D

Description: MP940D

Model: JEPMC-MC410

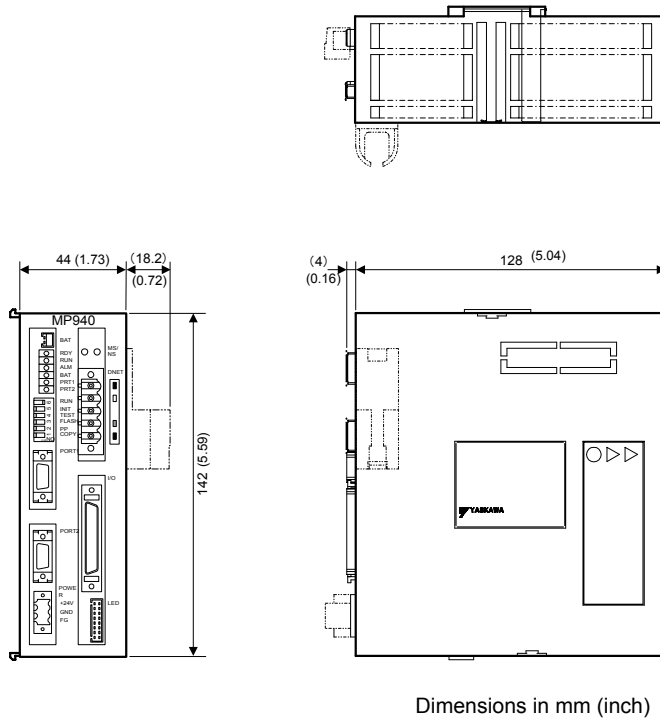

B Lists of Parameters

This section provides lists of SGDH SERVOPACK parameters, switches, input signal selections, output signal selections, auxiliary functions, and monitor modes.

B.1 Classification of Parameters	-----	B-2
B.2 Parameters	-----	B-2
B.3 Switches	-----	B-6
B.4 Input Signal Selections	-----	B-10
B.5 Output Signal Selections	-----	B-11
B.6 Auxiliary Functions	-----	B-12
B.7 Monitor Modes	-----	B-13

B.1 Classification of Parameters

Parameters can be classified into the following types.

Type	Parameter No.	Description
Function Selection Constants	Pn000 to Pn005	Selects control mode, and basic functions and application functions, such as stop method if an alarm occurs.
Gain Related Constants	Pn100 to Pn123	Sets values for speed loop gain, and position loop gain, etc.
Position Related Constants	Pn200 to Pn208	Sets position control parameters, such as type of reference pulse input and electronic gear ration settings, etc.
Speed Related Constants	Pn300 to Pn308	Sets the speed control parameters, such as the speed reference input gain, the soft start acceleration and deceleration time settings, etc.
Torque Related Constants	Pn400 to Pn409	Sets the torque control parameters, such as torque reference input gain, forward and reverse torque limit settings, etc.
Sequence Related Constants	Pn500 to Pn512	Sets the output conditions for sequence signals, select and change I/O signals and allocations.
Other Constants	Pn600 to Pn601	Reserved constants, and specifies the capacity of external regenerative resistance.
Execution of Auxiliary Functions	Fn000 to Fn012	Executes support functions such as JOG mode operation, etc.
Monitor Modes	Un000 to Un00D	Monitors speed and torque reference values, and checks I/O signal ON/OFF, etc.

B.2 Parameters

The following list shows parameters and their settings.

Category	Parameter No.	Name	Unit	Lower Limit	Upper Limit	Default Setting	Reference
Function Selection Constants	Pn000	Function Selection Basic Switches (See note 3.)	-	-	-	0000	
	Pn001	Function Selection Application Switches 1	-	-	-	0000	
	Pn002	Function Selection Application Switches 2 (See note 3.)	-	-	-	0000	
	Pn003	Function Selection Application Switches 3 (See note 3.)	-	-	-	0002	
	Pn004	Reserved constants	-	-	-	0	
	Pn005	Function Selection Application Switches 5	-	-	-	0	

Category	Parameter No.	Name	Unit	Lower Limit	Upper Limit	Default Setting	Reference
Gain Related Constants	Pn100	Speed Loop Gain	Hz	1	2000	40	
	Pn101	Speed Loop Integral Time Constant	0.01 ms	15	51200	2000	
	Pn102	Position Loop Gain	1/s	1	2000	40	
	Pn103	Inertia Ratio	%	0	10000	100	
	Pn104	2nd Speed Loop Gain	Hz	1	2000	40	
	Pn105	2nd Speed Loop Integral Time Constant	0.01 ms	15	51200	2000	
	Pn106	2nd Position Loop Gain	1/s	1	2000	40	
	Pn107	Bias	r/min	0	450	0	
	Pn108	Bias Width Addition	reference units	0	250	7	
	Pn109	Feed-forward	%	0	100	0	
	Pn10A	Feed-forward Filter Time Constant	0.01 ms	0	6400	0	
	Pn10B	Gain-related Application Switches	-	-	-	0000	
	Pn10C	Mode Switch Torque Reference	%	0	800	200	
	Pn10D	Mode Switch Speed Reference	r/min	0	10000	0	
	Pn10E	Mode Switch Acceleration	10 r/min/s	0	3000	0	
	Pn10F	Mode Switch Error Pulse	reference units	0	10000	0	
	Pn110	Online Autotuning Switches	-	-	-	0000	
Pn111	Speed Feedback Compensation (See note 2.)	%	1	100	100		
Gain Related Constants	Pn112	Fixed parameters (Do not change.)	%	0	1000	100	
	Pn113		-	0	10000	1000	
	Pn114		-	0	400	200	
	Pn115		-	0	1000	32	
	Pn116		-	0	1000	16	
	Pn117		%	20	100	100	
	Pn118		%	50	100	100	
	Pn119		1/s	1	2000	50	
	Pn11A		0.1%	1	2000	1000	
	Pn11B		Hz	1	150	50	
	Pn11C		Hz	1	150	70	
	Pn11D		%	0	150	100	
	Pn11E		%	0	150	100	
	Pn11F		Ms	0	2000	0	
	Pn120		0.01 ms	0	51200	0	
Pn121	Hz	10	250	50			
Pn122	Hz	0	250	0			
Pn123	%	0	100	0			

B

Category	Parameter No.	Name	Unit	Lower Limit	Upper Limit	Default Setting	Reference
Position Related Constants	Pn200	Position Control Reference Selection Switches (See note 3.)	-	-	-	0000	
	Pn201	PG Divider (See note 3.)	P/r	16	16384	16384	
	Pn202	Electronic Gear Ratio (Numerator) (See note 3.)	-	1	65535	4	
	Pn203	Electronic Gear Ratio (Denominator) (See note 3.)	-	1	65535	1	
	Pn204	Position Reference Accel/Decel Constant	0.01 ms	0	6400	0	
	Pn205	Multi-turn Limit Setting (See notes 1 and 3.)	rev	0	65535	65535	
	Pn206	Fixed parameter (Do not change.)	P/R	513	32768	16384	
	Pn207	Position Control Function Switches (See note 3.)	-	-	-	0000	
	Pn208	Position Reference Movement Averaging Time	0.01 ms	0	6400	0	
Speed Related Constants	Pn300	Speed Reference Input Gain	0.01 V/rated speed	150	3000	600	
	Pn301	Speed 1	r/min	0	10000	100	
	Pn302	Speed 2	r/min	0	10000	200	
	Pn303	Speed 3	r/min	0	10000	300	
	Pn304	Jog Speed	r/min	0	9999	500	
	Pn305	Soft Start Acceleration Time	ms	0	10000	0	
	Pn306	Soft Start Deceleration Time	ms	0	10000	0	
	Pn307	Speed Reference Filter Time Constant	0.01 ms	0	65535	40	
	Pn308	Speed Feed-forward Filter Time Constant	0.01 ms	0	65535	0	
Torque related constants	Pn400	Torque Reference Input Gain	0.1 V/rated torque	10	100	30	
	Pn401	Torque Reference Filter Time Constant	0.01 ms	0	65535	100	
	Pn402	Forward Torque Limit	%	0	800	800	
	Pn403	Reverse Torque Limit	%	0	800	800	
	Pn404	Forward External Torque Limit	%	0	800	100	
	Pn405	Reverse External Torque Limit	%	0	800	100	
	Pn406	Emergency Stop Torque	%	0	800	800	
	Pn407	Speed Limit during Torque Control	r/min	0	10000	10000	
	Pn408	Torque Function Switches	-	-	-	0000	
	Pn409	Notch Filter Frequency	Hz	50	2000	2000	

Category	Parameter No.	Name	Unit	Lower Limit	Upper Limit	Default Setting	Reference
Se- quence related constants	Pn500	Positioning Completed Width	reference units	0	250	7	
	Pn501	Zero Clamp Level	r/min	0	10000	10	
	Pn502	Rotation Detection Level	r/min	1	10000	20	
	Pn503	Speed Coincidence Signal Output Width	r/min	0	100	10	
	Pn504	NEAR Signal Width	reference units	1	250	7	
	Pn505	Overflow Level	256 reference units	1	32767	1024	
	Pn506	Brake Reference Servo OFF Delay Time	10 ms	0	50	0	
	Pn507	Brake Reference Output Speed Level	r/min	0	10000	100	
	Pn508	Timing for Brake Reference Output during Motor Operation	10 ms	10	100	50	
	Pn509	Momentary Hold Time	ms	20	1000	20	
	Pn50A	Input Signal Selections 1 (See note 3.)	-	-	-	2100	
	Pn50B	Input Signal Selections 2 (See note 3.)	-	-	-	6543	
	Pn50C	Input Signal Selections 3 (See note 3.)	-	-	-	8888	
	Pn50D	Input Signal Selections 4 (See note 3.)	-	-	-	8888	
	Pn50E	Output Signal Selections 1 (See note 3.)	-	-	-	3211	
	Pn50F	Output Signal Selections 2 (See note 3.)	-	-	-	0000	
	Pn510	Output Signal Selections 3 (See note 3.)	-	-	-	0000	
	Pn511	Input Signal Selections 5 (See note 3.)	-	-	-		
Pn512	Output Signal Reversal Settings	-	-	-	0		
Other constants	Pn600	Regenerative Resistor Capacity (See note 4.)	10 W	0	1000	0	
	Pn601	Fixed parameter (Do not change.)	-	0	1000	0	

* 1. The multi-turn limit is enabled only when the absolute encoder mode is set to 2. With all other settings, the multi-turn limit will be processed as 65535 even if the setting data is changed.

- The multiturn limit must be changed only for special applications. Changing this limit inappropriate or unintentionally can be dangerous.

* 2. The setting of parameter Pn111 is valid only when parameter Pn110.1 is set to 0.

- * 3. After changing these parameters, turn OFF the main circuit and control power supplies and then turn them ON again to enable the new settings.
- * 4. Normally set to “0”. When using an External Regenerative Resistor, set the capacity (W) of the regenerative resistor.

Note: The shaded parameters are reserved for system use and cannot be set.

B.3 Switches

The following list shows the switches and their default settings.

Parameter	Digit Place	Name	Setting	Contents	Default Setting
Pn000 Function Selection Basic Switches	0	Direction Selection	0	Sets CCW as forward direction.	0
			1	Sets CW as forward direction (reverse rotation mode).	
	1	Control Method Selection	0	Speed control (analog reference)	0
			1	Position control (pulse train reference)	
			2	Torque control (analog reference)	
			3	Internal set speed control (contact reference)	
			4	Internal set speed control (contact reference)/Speed control (analog reference)	
			5	Internal set speed control (contact reference)/Position control (pulse train reference)	
			6	Internal set speed control (contact reference)/Torque control (analog reference)	
			7	Position control (pulse train reference)/Speed control (analog reference)	
			8	Position control (pulse train reference)/Torque control (analog reference)	
			9	Torque control (analog reference)/Speed control (analog reference)	
			A	Speed control (analog reference)/Zero clamp	
			B	Position control (pulse train reference)/Position control (Inhibit)	
	2	Axis Address	0 to F	-	0
3	Reserved		-	0	

Parameter	Digit Place	Name	Setting	Contents	Default Setting
Pn001 Function Selection Application Switches	0	Servo OFF or Alarm Stop Mode	0	Stops the motor by applying dynamic brake (DB).	0
			1	Stops the motor by applying dynamic brake (DB) and then releases DB.	
			2	Makes the motor coast to a stop state without using the dynamic brake (DB).	
	1	Overtravel Stop Mode	0	Stops the motor using the dynamic brake (DB).	0
			1	Sets the torque of Pn406 to the maximum value, decelerates the motor to a stop, and then sets it to servolock state.	
			2	Sets the torque of Pn406 to the maximum value, decelerates the motor to a stop, and then sets it to coasting state.	
	2	AC/DC Power Input Selection	0	Not applicable to DC power input: Input AC power supply through L1, L2, and (L3) terminals.	0
			1	Applicable to DC power input: Input DC power supply through (+)1 and (-) terminals.	
	3	Warning Code Output Selection	0	ALO1, ALO2, and ALO3 output only alarm codes.	0
			1	ALO1, ALO2, and ALO3 output both alarm codes and warning codes. While warning codes are output, ALM signal output remains ON (normal state).	
Pn002 Function Selection Application Switches	0	Speed Control Option (T-REF Terminal Allocation)	0	None	0
			1	Uses T-REF as an external torque limit input.	
			2	Uses T-REF as a torque feed-forward input.	
	1	Torque Control Option (V-REF Terminal Allocation)	0	None	0
			1	Uses V-REF as an external speed limit input.	
	2	Absolute Encoder Usage	0	Uses absolute encoder as an absolute encoder.	0
			1	Uses absolute encoder as an incremental encoder.	
			2	Uses absolute encoder as an absolute encoder. Uses multi-turn limit.	
	3	Reserved constant	0	-	0

B

Parameter	Digit Place	Name	Setting	Contents	Default Setting
Pn003 Function Selection Application Switches	0	Analog Monitor 1 Torque Reference Monitor	0	Motor speed: 1 V/1000 r/min.	2
			1	Speed reference: 1 V/1000 r/min.	
	1	Analog Monitor 2 Speed Reference Monitor	2	Torque reference: 1 V/100%	0
			3	Position error: 0.05 V/1 reference unit	
			4	Position error: 0.05 V/100 reference unit	
			5	Reference pulse frequency (converted to r/min): 1 V/1000 r/min.	
			6	Motor speed × 4: 1 V/250 r/min.	
			7	Motor speed × 8: 1 V/125 r/min.	
			8	Fixed parameters (Do not change.)	
			9		
			A		
			B		
	C				
D					
2	Reserved	-	-	0	
		-	-	0	
		-	-	0	
Pn005 Function Selection Application Switches	0	Brake Control Function Selection	0	Uses the SERVOPACK brake sequence.	0
			1	Uses the host controller brake sequence.	0
	1	Reserved	0		0
	2	Reserved	0		0
	3	Reserved	0		0
Pn10B	0	Mode Switch Selection	0	Uses internal torque reference as the condition (Level setting: Pn10C)	0
			1	Uses speed reference as the condition (Level setting: Pn10D)	
			2	Uses acceleration as the condition (Level setting: Pn10E)	
			3	Uses error pulse as the condition (Level setting: Pn10F)	
			4	No mode switch function available	
	1	IP control	0	PI control	0
			1	IP control	
	2	Reserved	0	-	0
	3	Reserved	0	-	0

Parameter	Digit Place	Name	Setting	Contents	Default Setting	
Pn110 Online Au- totuning Switches	0	Online Autotuning Method	0	Tunes only at the beginning of operation.	0	
			1	Always tunes.		
			2	Does not perform autotuning.		
	1	Speed Feedback Compensation Selection	0	Enabled	0	
			1	Disabled		
	2	Friction Compensation Selection	0	Friction compensation: Disabled	0	
			1	Friction compensation: Small		
			2	Friction compensation: Large		
	3	Reserved Constant (Do not change.)	0	-	0	
			1	-		
	Pn200 Position Control Referenc- es Selec- tion Switches	0	Reference Pulse Form	0	Sign + pulse, positive logic	0
				1	CW + CCW, positive logic	
2				Phase A + Phase B (× 1), positive logic		
3				Phase A + Phase B (× 2), positive logic		
4				Phase A + Phase B (× 4), positive logic		
5				Sign + pulse, negative logic		
6				CW + CCW, negative logic		
7				Phase A + Phase B (× 1), negative logic		
8				Phase A + Phase B (× 2), negative logic		
9				Phase A + Phase B (× 4), negative logic		
1		Error Counter Clear Signal Form	0	Clears error counter when the signal goes high.	0	
			1	Clears error counter at the rising edge of the signal.		
			2	Clears error counter when the signal goes low.		
			3	Clears error counter at the falling edge of the signal.		
2		Clear Operation	0	Clears error counter at the baseblock.	0	
			1	Does not clear error counter. (Possible to clear error counter only with CLR signal.)		
			2	Clears error counter when an alarm occurs.		
3		Filter Selection	0	Reference input filter for line driver signals.	0	
			1	Reference input filter for open collector signals.		

B

B.4 Input Signal Selections

The following list shows input signal selections and their default settings.

Parameter	Digit Place	Name	Setting	Contents	Default Setting
Pn50A	0	Input Signal Allocation Mode	0	Sets the input signal allocation for the sequence to the same one as for the SGDB SERVOPACK. (See note.)	0
			1	Possible to freely allocate the input signals.	
	1	/S-ON Signal Mapping (Servo ON when low.)	0	Inputs from the SI0 (CN1-40) input terminal.	0: SI0
			1	Inputs from the SI1 (CN1-41) input terminal.	
			2	Inputs from the SI2 (CN1-42) input terminal.	
			3	Inputs from the SI3 (CN1-43) input terminal.	
			4	Inputs from the SI4 (CN1-44) input terminal.	
			5	Inputs from the SI5 (CN1-45) input terminal.	
			6	Inputs from the SI6 (CN1-46) input terminal.	
			7	Sets signal ON	
			8	Sets signal OFF	
			9	Inputs the reverse signal from the SI0 (CN1-40) input terminal.	
			A	Inputs the reverse signal from the SI1 (CN1-41) input terminal.	
			B	Inputs the reverse signal from the SI2 (CN1-42) input terminal.	
C	Inputs the reverse signal from the SI3 (CN1-43) input terminal.				
D	Inputs the reverse signal from the SI4 (CN1-44) input terminal.				
E	Inputs the reverse signal from the SI5 (CN1-45) input terminal.				
F	Inputs the reverse signal from the SI6 (CN1-46) input terminal.				
2	/P-CON Signal Mapping (P control when low.)	0 to F	Same as above.	1: SI1	
3	P-OT Signal Mapping (Over-travel when high.)	0 to F	Same as above.	2: SI2	
Pn50B	0	N-OT Signal Mapping (Over-travel when high.)	0 to F	Same as above.	3: SI3
	1	/ALM-RST Signal Mapping (Alarm reset when low.)	0 to F	Same as above.	4: SI4
	2	/P-CL Signal Mapping (Torque control when low.)	0 to F	Same as above.	5: SI5
	3	/N-CL Signal Mapping (Torque control when low.)	0 to F	Same as above.	6: SI6

Parameter	Digit Place	Name	Setting	Contents	Default Setting
Pn50C	0	/SPD-D Signal Mapping (Internal Set Speed Selection)	0 to F	Same as above.	8: OFF
	1	/SPD-A Signal Mapping (Internal Set Speed Selection)	0 to F	Same as above.	8: OFF
	2	/SPD-B Signal Mapping (Internal Set Speed Selection)	0 to F	Same as above.	8: OFF
	3	/C-SEL Signal Mapping (Control Mode Switching)	0 to F	Same as above.	8: OFF
Pn50D	0	/ZCLAMP Signal Mapping (Zero Clamping)	0 to F	Same as above.	8: OFF
	1	/INHIBIT Signal Mapping (Disabling Reference Pulse)	0 to F	Same as above.	8: OFF
	2	/G-SEL Signal Mapping (Gain Switching)	0 to F	Same as above.	8: OFF
	3	(Reserved)	0 to F	Same as above.	8: OFF
Pn511	0	/DEC signal mapping (decrements when signal is ON (low)).	0 to F	Same as above.	8: OFF
	1	/EXT1 signal mapping (external latch when signal is ON (low)).	0 to F	Same as above.	8: OFF
	2	/EXT2 signal mapping (external latch when signal is ON (low)).	0 to F	Same as above.	8: OFF
	3	/EXT3 signal mapping (external latch when signal is ON (low)).	0 to F	Same as above.	8: OFF

Note: When Pn50A.0 is set to 0 for the SGDB SERVOPACK, only the following modes are compatible: Pn50A.1=7, Pn50A.3=8, and Pn50B.0=8.

B.5 Output Signal Selections

Parameter	Digit Place	Name	Setting	Contents	Default Setting
Pn50E	0	/COIN Signal Mapping	0	Disabled.	1: SO1
			1	Outputs from the SO1 (CN1-25, 26) output terminal.	
			2	Outputs from the SO2 (CN1-27, 28) output terminal.	
			3	Outputs from the SO3 (CN1-29, 30) output terminal.	
	1	/V-CMP Signal Mapping	0 to 3	Same as above.	1: SO1
	2	/TGON Signal Mapping	0 to 3	Same as above.	2: SO2
	3	/S-RDY Signal Mapping	0 to 3	Same as above.	3: SO3

Parameter	Digit Place	Name	Setting	Contents	Default Setting
Pn50F	0	/CLT Signal Mapping	0 to 3	Same as above.	0: Not used
	1	/VLT Signal Mapping	0 to 3	Same as above.	0: Not used
	2	/BK Signal Mapping	0 to 3	Same as above.	0: Not used
	3	/WARN Signal Mapping	0 to 3	Same as above.	0: Not used
Pn510	0	/NEAR Signal Mapping	0 to 3	Same as above.	0: Not used
	1	Reserved	0	-	0
	2	Reserved	0	-	0
	3	Reserved	0	-	0
Pn512	0	Output Signal Reversal for SO1 (CN1-25 and 26)	0	Output signal is not reversed.	0: Not reversed
			1	Output signal is reversed.	
	1	Output Signal Reversal for SO2 (CN1-27 and 28)	0	Output signal is not reversed.	0: Not reversed
			1	Output signal is reversed.	
	2	Output Signal Reversal for SO3 (CN1-29 and 30)	0	Output signal is not reversed.	0: Not reversed
			1	Output signal is reversed.	
	3	Reserved	-	-	0

Note: 1. When more than one signal is allocated to the same output circuit, data is output using OR logic.

2. Depending on the control mode, undetected signals are treated as OFF. For example, in the speed control mode, the /COIN signal is treated as OFF.

3. Types of /WARN signals: Overload and regenerative overload.

B.6 Auxiliary Functions

The following list shows the available auxiliary functions.

Parameter	Function
Fn000	Alarm traceback data display.
Fn001	Rigidity setting during online autotuning.
Fn002	JOG mode operation.
Fn003	Zero-point search mode.
Fn004	(Fixed parameter)
Fn005	Parameter settings initialization.
Fn006	Alarm traceback data clear.
Fn007	Writing to EEPROM inertia ratio data obtained from online autotuning.
Fn008	Absolute encoder multi-turn reset and encoder alarm reset.
Fn009	Automatic tuning of analog (speed, torque) reference offset
Fn00A	Manual adjustment of speed reference offset.
Fn00B	Manual adjustment of torque reference offset
Fn00C	Manual zero-adjustment of analog monitor output.
Fn00D	Manual gain-adjustment of analog monitor output.
Fn00E	Automatic offset-adjustment of motor current detection signal.
Fn00F	Manual offset-adjustment of motor current detection signal.

Parameter	Function
Fn010	Password setting (protects parameters from being changed).
Fn011	Motor models display.
Fn012	Software version display.
Fn013	Multi-turn limit setting change when a Multi-turn Limit Disagreement Alarm (A.CC) occurs.

B.7 Monitor Modes

The following list shows the available auxiliary functions.

Parameter	Content of Display	Unit	Remarks
Un000	Actual motor speed	r/min	-
Un001	Input speed reference	r/min	-
Un002	Internal torque reference	%	Value for rated torque
Un003	Rotation angle 1	pulse	Number of pulses from the zero point
Un004	Rotation angle 2	deg	Angle from the zero point (electrical angle)
Un005	Input signal monitor	-	-
Un006	Output signal monitor	-	-
Un007	Input reference pulse speed	r/min	-
Un008	Error counter value	reference units	Amount of position error
Un009	Accumulated load rate	%	Value for the rated torque as 100% Displays effective torque in 10-s cycle.
Un00A	Regenerative load rate	%	Value for the processable regenerative power as 100% Displays effective torque in 10-s cycle.
Un00B	Power consumed by DB resistance	%	Value for the processable power when dynamic brake is applied as 100% Displays effective torque in 10-s cycle.
Un00C	Input reference pulse counter	-	Displayed in hexadecimal.
Un00D	Feedback pulse counter	-	Displayed in hexadecimal.

B

C Motion Parameter Tables

This section explains the meaning of, and difference between using or not using the motion parameters.

C.1 Motion Fixed Parameters	-----	C-2
C.2 Motion Setting Parameters	-----	C-5
C.3 Motion Monitoring Parameters	-----	C-12



C.1 Motion Fixed Parameters

Motion fixed parameters are set only once unless there is a configurational, specification, or other machine-related change. They are set from the Fixed Parameter Setting Screen on the CP-717.

Table C.1 Motion Fixed Parameters

No.	Name	Bit Name (Setting Range)	Meaning	Remarks
1	Axis Selection (USESEL)	0 or 1 (Default = 1)	0: Not used 1: Use	
7	Rated Motor Speed Setting (NR)	1 to 32000	1 = 1 r/min	Used in simulation mode
13	DI Latch Signal Selection (DIINTSEL)	0 or 1 (Default = 0)	0: DI input signal 1: C pulse input signal	
14	Additional Function Selections (AFUNCSEL)	Bit 0 to 1: Not used.	-	-
		Bit 2: LIMITSEL	Limit Switch Signal Selection	0: Use OBC001F. 1: Use the DI signal.
		Bit 3 to 6: Not used.	-	-
		Bit 7: MCMDSSEL	Motion Command Code Selection	0: Not used. 1: Use.
		Bit 8 to 11: Not used.	-	-
		Bit 12 to 15: EOV_MULTI	Deviation error detection coefficient	0 to 15
15	Not used.	-	-	-
16	Simulation Mode Selection	0 to 2 (Default = 0)	0: Normal operation mode	
			1: Simulation mode	
17	Motion Controller Function Selection Flags (SVFUNCSEL)	Bit 0 to 3: 0 to 7 CMD_UNIT	Reference Unit Selection	0: pulse (Electronic gear disabled)
				1: mm
				2: deg
				3: inch
		Bit 4: USE_GEAR	Electronic Gear Selection	0: Disabled 1: Enabled
		Bit 5: PMOD_SEL	Axis Selection	0: Finite length axis 1: Infinite length axis
		Bit 6: USE_BKRSH	Backlash Compensation Enabled Selection	0: Disabled 1: Enabled
		Bit 7: USE_SLIMP	Positive Software Limit Selection	0: Disabled 1: Enabled
		Bit 8: USE_SLIMN	Negative Software Limit Selection	0: Disabled 1: Enabled
		Bit 9: USE_OV	Override Selection	0: Disabled 1: Enabled
Bit 10: INV_DEC	Deceleration Limit Switch Inversion Selection	0: Do not reverse. 1: Reverse.		

No.	Name	Bit Name (Setting Range)	Meaning	Remarks
17	Motion Controller Function Selection Flags (SVFUNCSEL) (Contd.)	Bit 11 to 12: Not used.	-	-
		Bit 13: OVT1_SEL	Positive Overtravel Selection	0: Disabled 1: Enabled
		Bit 14: OVT2_SEL	Negative Overtravel Selection	0: Disabled 1: Enabled
18	Number of Digits Below Decimal Point (DECNUM)	0 to 5 (Default = 3)	Sets the number of digits right of the decimal point in commands. (Example) With 3 digits right of the decimal point mm: 1 reference unit = 0.001 mm deg: 1 reference unit = 0.001 deg inch: 1 reference unit = 0.001 inch	Minimum reference unit is determined by this parameter as well as by the Reference Unit Selection (see fixed servo parameter no. 17.).
19	Distance Traveled Per Machine Rotation (PITCH)	1 to $2^{31}-1$ (Default = 10000)	1 = 1 reference unit	
21	Servomotor Gear Ratio (GEAR_MOTOR)	1 to 65535 (Default = 1)	1 = 1 rotation	
22	Machine Gear Ratio (GEAR_MACHINE)	1 to 65535 (Default = 1)	1 = 1 rotation	
23	Infinite Length Axis Reset Position (POS MAX)	1 to $2^{31}-1$ (Default = 360000)	1 = 1 reference unit	
27	Positive Software Limit (SLIMP)	-2^{31} to $2^{31}-1$ (Default = $2^{31}-1$)	1 = 1 reference unit	
29	Negative Software Limit (SLIMN)	-2^{31} to $2^{31}-1$ (Default = 2^{31})	1 = 1 reference unit	
31	Zero Point Return Method (ZRETSEL)	0 to 7 (Default = 0)	0: DEC1 + Phase-C pulse	
			1: ZERO	
			2: DEC1 + ZERO	
			3: Phase-C pulse	
			4: DEC2 + ZERO	
			5: DEC1 + LMT + ZERO	
			6: DEC2 + Phase-C pulse	
			7: DEC1 + LMT + Phase-C pulse	
32	Backlash Compensation (BKLSH)	0 to 32767 (Default = 0)	1 = 1 reference unit	
33	Number of Feedbacks per Motor Rotation	4 to 2147483647	1 = 1 pulse/rev (Set using $\times 4$)	Used in simulation mode

No.	Name	Bit Name (Setting Range)	Meaning	Remarks
36	Bias Speed for Exponential Acceleration and Deceleration Filter (EXPBIAS)	0 to 32767	1 = 10 ⁿ reference units/min.	
37 to 48	Not used.	-	-	-

C.2 Motion Setting Parameters

Motion setting parameters serve as instructions to SVA Modules. They are located at the top of high-speed scans and are sent together to SVA Modules. Motion can be controlled simply by setting parameters in these registers.

Table C.1 Motion Setting Parameters

No.	Name	Register No.	Bit Name (Setting Range)	Meaning	Remarks
1	RUN Mode Settings (RUNMODE)	OWC000	Bit 0: NCON	Speed Reference Output Mode	
			Bit 1: TCON	Torque Reference Output Mode	
			Bit 2: PCON	Position Control Mode	
			Bit 3: PHCON	Phase Control Mode	
			Bit 4: ZRN	Zero Point Return Mode	
			Bit 5: PHTEST	Phase Control Test Signal	
			Bit 6: ACR	Alarm Clear	
			Bit 7: PHREFOFF	Phase Reference Disable	
			Bit 8: MCDSEL	0: Motion command code (OWC020) disabled 1: Motion command code (OWC020) enabled	
			Bit 9: ZRNDIR	Zero Point Return Direction Selection 0: Negative (deceleration) 1: Positive (acceleration)	
			Bit 10: ABSRD	Absolute Position Read Request	
			Bit 11:	Feed forward Compensation During Control Mode Switching	
			Bit 12:	Not used.	
			Bit 13: DIINTREQ	DI Latch Request	
			Bit 14:	Not used.	
Bit 15: IRESET	Phase Control Integration Reset				
2	RUN Command Settings (SVRUNCMD)	OWC001	Bit 0: RUN (D00)	RUN Servo ON	
			Bit 1: P-CON	Speed Loop P/PI Switching	
			Bit 2: G-SEL	Gain Selection	
			Bit 3: P-CL	Forward External Torque Control Input	
			Bit 4: N-CL	Reverse External Torque Control Input	
			Bit 5: ZCLAMP	Zero Clamp Input	
			Bit 6: PHSCZNSEL	Phase Control Mode Synchronous Scan Selection 0: H scan 1: S scan	
			Bit 7: PSCANSEL	Control Loop Synchronous Scan Selection 0: H scan 1: S scan	
			Bit 8: ACCSEL	Select Acceleration/Deceleration Function ON/OFF during Simple Positioning 0: H scan 1: S scan	

No.	Name	Register No.	Bit Name (Setting Range)	Meaning	Remarks
2	RUN Command Settings (SVRUNCMD) (Contd.)	OWC001	Bit 9: SEGSEL	Position Control Mode Segment partition function ON/OFF selection 0: ON 1: OFF	
			Bit 10:	Not used.	
			Bit 11:	Not used.	
			Bit 12: USE_BUF	Position Reference Value Selection 0: OLC012 1: Position buffer	
			Bit 13: SPDTYPE	Speed Reference Value Selection 0: OLC022 valid for rapid traverse speed. Approach speed (OWC00A) and creep speed (OWC00B) unit is 1 = 10n reference units/min. 1: OWC015 valid for rapid traverse speed. Approach speed (OWC00A) and creep speed (OWC00B) unit is 1 = 0.01%.	
			Bit 14: XREFTYPE	Position Reference Type 0: Position reference (OLC012) is an absolute position. 1: Position reference (OLC012) is an incremental value.	
3	Positive Torque Limit Setting (TLIMP)	OWC002	-32768 to 32767 (Default = -30000)	1 = 0.01% (-30000 = -300.00%)	
4	Not used.	OWC003	-	Set to "0."	
5	Positive Speed Limiter Setting (NLIMP)	OWC004	0 to 32767 (Default = 15000)	1 = 0.01% (15000 = 150.00%)	
6	Negative Speed Limiter Setting (NLIMN)	OWC005	0 to 32767 (Default = 15000)	1 = 0.01% (15000 = 150.00%)	
7	Machine Coordinate System Zero Point Offset Setting (ABSOFF)	OLC006	-2^{31} to $2^{31}-1$ (Default = 0)	1 = 1 reference unit 1 = 1 pulses for pulse unit	
9	Not used.	OLC008	-	Set to "0."	

No.	Name	Register No.	Bit Name (Setting Range)	Meaning	Remarks
11	Approach Speed Setting (Napr)	OWC00A	0 to 32767 (Default = 0)		The unit will vary with the speed reference selection (OBC001D). When the speed reference value selection = 0. 1 = 10 ⁿ reference units/min (n = Number of digits below decimal) Pulse unit: 1 = 1,000 pulses/min (PO-01: 1 = 100 pulses/min.) mm unit: 1 = 1 mm/min deg unit: 1 = 1 deg/min inch unit: 1 = 1inch/min When the speed reference value selection = 1. 1 = 0.01% (1000 = 10.00%)
12	Creep Speed Setting (Nclp)	OWC00B	0 to 32767 (Default = 0)		
13	Linear Acceleration Time Constant (NACC)	OWC00C	0 to 32767 (Default = 0)	1 = 1ms (300ms)	
14	Linear Deceleration Time Constant (NDEC)	OWC00D	0 to 32767 (Default = 0)	1 = 1ms (300ms)	
15	Positioning Completed Range Setting (PEXT)	OWC00E	0 to 65535 (Absolute value) (Default = 10)	1 = 1 reference unit 1 = 1 pulses for pulse unit	
16	Error Count Alarm Detection Setting (EOV)	OWC00F	0 to 65535 (Absolute value) (Default = 65535)	1 = 1pulse (0 = No error detection)	
17	Position Loop Gain Setting (kp)	OWC010	0 to 32767 (Default = 300)	1 = 0.1/s (300 = 30.0)	
18	Feed Forward Gain Setting (kf)	OWC011	0 to 200 (Default = 0)	1 = 1% (10 = 10%)	
19	Position Reference Setting or Position Buffer Number (XREF)	OLC012	-2 ³¹ to 2 ³¹ -1 (Default = 0)	1 = 1 reference unit 1 = 1 pulses for pulse unit Position reference value selection When (OBC001C) = 1 Position buffer no. (1 to 256)	
21	Filter Time Constant Setting (NNUM)	OWC014	Constant during Position Control Mode and S-curved (moving average) movement with the Speed Reference Output Mode and motion command disabled. 0 to 255 (1 = 1 time) (0 = 1 = No averaging)		
			Constant during S-curved (moving average) movement when bits 4 to 7 at OWC021 are set to "2." 0 to 255 (1 = 1 time) (0 = 1 = No averaging) SVB range is 0 to 65535 (1 = 0.1 ms)		
			Constant during exponential acceleration/deceleration when bits 4 to 7 at OWC021 are set to "1." 0 to 32767 (1 = 1 ms) SVB range is 0 to 65535 (1 = 0.1 ms)		
22	Speed Reference Setting (NREF)	OWC015	-32768 to 32767 (Default = 0)	1 = 0.01% (5000 = 50.00%)	

C

No.	Name	Register No.	Bit Name (Setting Range)	Meaning	Remarks
23	Phase Bias Setting (PHBIAS)	OLC016	-2^{31} to $2^{31}-1$ (Default = 0)	1 = 1pulse	
25	Speed Compensation Setting (NCOM)	OWC018	-32768 to 32767 (Default = 0)	1 = 0.01% (100 = 1.00%)	
26	Proportional Gain Setting (Pv)	OWC019	0 to 32767 (Default = 300)	1 = 0.1/s (300 = 30.0)	
27	Integral Time Setting (Ti)	OWC01A	0 to 32767 (Default = 300)	1 = 1ms (0 = No integration) (300 = 0.300s)	
28	Torque Reference Setting (TREF)	OWC01B	-32768 to 32767 (Default = 0)	1 = 0.01% (10000 = 100.00%)	
29	Speed Limit Setting (NLIM)	OWC01C	-32768 to 32767 (Default = 15000)	1 = 0.01% (15000 = 150.00%)	
31	Pulse Bias Setting (PULBIAS)	OLC01E	-2^{31} to $2^{31}-1$ (Default = 0)	1 = 1 pulse	
33	Motion Command Code (MCMDCODE)	OWC020	0 to 65535 (Default = 0)	0: NOP	NO command
				1: POSING	Positioning
				2: EX_POSING	External position
				3: ZRET	Zero point return
				4: INTERPOLATE	Interpolation
				5: ENDOF_INTERPOLATE	Interpolation end segment
				6: LATCH	Interpolation with latch
				7: FEED	Feed
				8: STEP	Step
				9: ZSET	Zero point setting
10 to 65535: Not used.					

No.	Name	Register No.	Bit Name (Setting Range)	Meaning	Remarks
34	Motion Command Control Flags (MCMDCTRL) (Default = 0, all bits OFF)	OWC021	Bit 0: HOLD	Command Hold	
			Bit 1: ABORT	Command Abort	
			Bit 2: DIRECTION	Direction of Movement 0: Forward 1: Reverse	
			Bit 3: LAGRST	No Primary Lag (Same as primary lag Time Constant = 0)	
			Bit 4 to 7: FILTERTYPE	Filter Type Selection 0: No filter. 1: Exponential filter (exponential acceleration/deceleration) 2: Movement averaging filter (simple S-curved acceleration/deceleration)	
			Bit 8: POS_PPI	Position Loop P/PI Switch 0:P 1:PI	
			Bit 9: POS_IRST	Position Control Integration Reset	
			Bit 10: NCOMSEL	Speed Compensation (OWC018) during Position Control	
			Bit 11: SCMD	SGDH Serial Command Enabled Flag (0, 1)	
			Bit 12: LMT_L	Reverse Limit Signal for Zero Point Return	Enabled only when fixed parameter No. 14, Additional Function Selection is set to use OBC021x (setting parameter)
			Bit 13: LMT_R	Forward Limit Signal for Zero Point Return	
Bit 14: BUF_W	Position Buffer Write	0: No processing 1: Write			
Bit 15: BUF_R	Position Buffer Read	0: No processing 1: Read			
35	Rapid Traverse Speed (RV)	OLC022	0 to $2^{31}-1$ (Default = 3000)	1 = 10^n reference units/min (n = Number of digits below decimal) Pulse unit: 1 = 1,000 pulses/min mm unit: 1 = 1 mm/min deg unit: 1 = 1 deg/min inch unit: 1 = 1 inch/min	
37	External Positioning Travel Distance (EXMDIST)	OLC024	-2^{31} to $2^{31}-1$ (Default = 0)	1 = 1 reference unit	1 = 1 pulses for pulse unit
39	Stopping Distance (STOPDIST)	OLC026	-2^{31} to $2^{31}-1$ (Default = 0)	1 = 1 reference unit	For motion management
41	Step Travel Distance (STEP)	OLC028	0 to $2^{31}-1$ (Default = 0)	1 = 1 reference unit	
43	Zero Point Return Final Travel Distance (ZRNDIST)	OLC02A	-2^{31} to $2^{31}-1$ (Default = 0)	1 = 1 reference unit	

C

No.	Name	Register No.	Bit Name (Setting Range)	Meaning	Remarks
45	Override (OV)	OWC02C	0 to 32767 (Default = 10000)	1 = 0.01% (10000 = 100.00)	
46	Position Control Flags (POSCTRL) (Default = 0, all bits OFF)	OWC02D	Bit 0: MLK	Machine Lock Mode Setting 0: OFF 1: ON (Machine Lock Mode setting)	
			Bit 1: TPRSREQ	Request for Preset Number of POSMAX Turns 1: Request ON	
			Bit 2: ABSLDREQ	ABS System Infinite Length Position Control Data LOAD request 1: Request ON	
			Bit 3: PUNITSEL	Position Monitor 2 (ILC034) Unit Selection 0: Reference unit 1: Pulse unit	
			Bit 4 to 11:	Not used.	
47	Workpiece Coordinate System Offset (OFFSET)	OLC02E	-2^{31} to $2^{31}-1$ (Default = 0)	1 = 1 reference unit	1 = 1 pulses for pulse unit
49	Preset Number of POSMAX Turns Data (TURNPRS)	OLC030	-2^{31} to $2^{31}-1$ (Default = 0)	1 = 1 rotation	
51	Second In-position Width (INPWIDTH)	OLC032	0 to 65535 (Default = 0)	1 = 1 reference unit	1 = 1 pulses for pulse unit
52	Zero Point Position Output Width (PSETWIDTH)	OWC033	0 to 65535 (Default = 10)	1 = 1 reference unit	
53	Positioning Completed Check Time (PSETTIME)	OWC034	0 to 65535 (Default = 0)	1 = 1ms	
54	Position Control Integral Time (PTi)	OWC035	0 to 32767 (Default = 300)	1 = 1ms	
55	Upper/lower Limit for Position Control Integral (ILIMIT)	OLC036	-2^{31} to $2^{31}-1$ (Default = 32767)		
56	Primary Lag Time Constant (LAGTi)	OWC037	0 to 32767 (Default = 0)		

No.	Name	Register No.	Bit Name (Setting Range)	Meaning	Remarks
57	Lower-place Two Words of the Encoder Position at Shutdown	OLC038	-2^{31} to $2^{31}-1$ (Default = 0)	ABS System Infinite Length Position Control Data When the Load Request (OBC02D2) is ON: Lower-place Two Words of the Encoder Position at Shutdown (1 = 1 pulse)	
	Position Buffer Access Number (eposL)			When the Motion Command Control Flag BUF_W (OBC021E) = 1 or BUF_R (OBC021F) = 1: Position Buffer Access Number (1 to 256 = Enabled)	
	SGDH Serial Command Command Setting	OWC038	0 to 2	Read/write SGDH parameters when Motion Command Control Flag SCMD (OBC021B) = 1 1: Read data 2: Write data	
	SGDH Serial Command Address Setting	OWC039		Set the read/write address for the SGDH parameters when Motion Command Control Flag SCMD (OBC021B) = 1	
59	Upper-place Two Words of the Encoder Position at Shutdown	OLC03A	-2^{31} to $2^{31}-1$ (Default = 0)	ABS System Infinite Length Position Control Data When the Load Request (OBC02D2) is ON: Upper-place Two Words of the Encoder Position at Shutdown (1 = 1 pulse)	
	Position Buffer Write Data			Position Buffer Write Data when the Motion Command Control Flag BUF_W (OBC021E) = 1	
	SGDH Serial Command Data Setting	OWC03A		Set the setting data when the Motion Command Control Flag SCMD (OBC021B) = 1 and data write command (OWC038) = 2	
61	Lower-place Two Words of the Pulse Position at Shutdown	OLC03C	-2^{31} to $2^{31}-1$ (Default = 0)	ABS System Infinite Length Position Control Data When the Load Request (OBC02D2) is ON: Lower-place Two Words of the Pulse Position at Shutdown (1 = 1 pulse)	
63	Upper-place Two Words of the Pulse Position at Shutdown	OLC03E	-2^{31} to $2^{31}-1$ (Default = 0)	ABS System Infinite Length Position Control Data When the Load Request (OBC02D2) is ON: Upper-place Two Words of the Pulse Position at Shutdown (1 = 1 pulse)	

C

C.3 Motion Monitoring Parameters

Motion monitoring parameters are parameters reported by SVA Modules. They are located at the top of high-speed scans and are reported together. Use these parameters to control applications and to debug user programs.

Table C.1 Motion Monitoring Parameters

No.	Name	Register No.	Bit Name (Setting Range)	Meaning	Remarks
1	RUN Status (RUNSTS)	IWC000	Bit 0: EOVER	Error Counter Over	
			Bit 1: PRMERR	Motion Setting Parameter Setting Error	
			Bit 2: FPRMERR	Motion Setting Parameter Setting Error	
			Bit 3: Not used.		
			Bit 4: Not used.		
			Bit 5: Not used.		
			Bit 6: Not used.		
			Bit 7: SVCRDY	Motion Controller RUN Ready	
			Bit 8: SVCRUN	Motion Controller RUN	
			Bit 9: DIRINV	Rotation Direction when Using Absolute Encoder	
			Bit 10: ABCRDC	Absolute Position Read Completed Signal	
			Bit 11: DIINT	DI Latch Completed Signal	
			Bit 12: FBPO	Feedback Pulse 0	
			Bit 13: POSCOMP	Positioning Completed Signal	
			Bit 14: Not used.		
Bit 15: ZRNC	Zero Point Return Completed Signal				
2	Servodriver Status (SYSTS)	IWC001	Bit 0: ALM	Servo alarm	
			Bit 1: WARN	Warning	
			Bit 2: V-CMP	Speed conformity	
			Bit 3: TGON	Detection during motor rotation	
			Bit 4: S-RDY	Servo ready	
			Bit 5: CLT	Torque limit detection	
			Bit 6: VLT	Speed limit detection	
			Bit 7: BK	Brake interlock	
			Bit 8: SVON	Servo ON completed	
			Bit 9: PON	Main circuit completed	
			Bit10 to Bit15	Not used	
3	Calculated Position in Machine Coordinate System (CPOS)	ILC002	-2^{31} to $2^{31}-1$	1 = 1 pulse or 1 = 1 reference unit 1 = 1 pulse for pulse unit Updated when the machine is locked.	
5	Target Position Difference Monitor (PTGDIF)	ILC004	-2^{31} to $2^{31}-1$	1 = 1 pulse or 1 = 1 reference unit 1 = 1 pulse for pulse unit	
7	Machine Coordinate System Latch Position (LPOS)	ILC006	-2^{31} to $2^{31}-1$	1 = 1 reference unit (1 = 1 pulse for pulse unit)	

No.	Name	Register No.	Bit Name (Setting Range)	Meaning	Remarks
9	Machine Coordinate System Feedback Position (APOS)	ILC008	-2^{31} to $2^{31}-1$	1 = 1 reference unit (1 = 1 pulse for pulse unit) Note: Will not be updated if the machine is locked.	
11	Position Error (PERR)	ILC00A	-2^{31} to $2^{31}-1$	1 = 1 pulse	
13	Speed Reference Output Monitor (SPDREF)	IWC00C	-32768 to 32767	1 = 0.01%	
14	Speed Monitor (NFB)	IWC00D	-32768 to 32767	1 = 0.01%	
15	Torque Monitor (TFB)	IWC00E	-32768 to 32767	1 = 0.01%	
16	Out of Range Parameter Number (ERNO)	IWC00F	1 to 65 101 to 148	Motion parameter error number Motion fixed parameter error number +100	
17	Cumulative Rotations from Absolute Encoder (ABSREV)	ILC010	0 to ± 99999	1 = 1 rotation	
19	Initial Incremental Pulses from Absolute Encoder (IPULSE)	ILC012	-2^{31} to $2^{31}-1$	1 = 1 pulse	
21	Motion Command Response Code (MCMDCODE)	IWC014	0 to 65535	Motion command that is currently executing. (Refer to OWC020 for details.)	
22	Motion Command Status (MCMDDSTS)	IWC015	Bit 0: BUSY	Command Executing Flag	
			Bit 1: HOLDL	Command Hold Completed	
			Bit 2: DEN	Distribution Completed	
			Bit 3: ZSET	Zero Point Setting Completed	
			Bit 4: EX_LATCH	External Positioning Signal Latched	
			Bit 5: FAIL	Command Error End	
			Bit 6: ZRNC	Zero Point Return Completed	
			Bit 7 to 15:	Not used.	
23	Number of Digits Below Decimal Point Monitor (DECNUMM)	IWC016	0 to 5	Copies motion fixed parameter Number of Digits Below Decimal Point.	
24	Position Control Status (POSSTS)	IWC017	Bit 0: MLKL	Machine Locked	
			Bit 1: ZERO	Zero Point Position	
			Bit 2: PSET2	Second In-position Completed	
			Bit 3: ABSLDE	ABS System Infinite Length Position Control Data Load Completed	
			Bit 4: TPRSE	Preset no. of POSMAX Turns Completed	
			Bit 5: GEARM	Copies Motion Fixed Parameter "Electronic Gear Enabled Selection."	
			Bit 6: MODSELM	Copies motion fixed parameter "Axis Selection."	
			Bit 7 to 11:	Not used.	
			Bit 12 to 15:	Not used.	

C

No.	Name	Register No.	Bit Name (Setting Range)	Meaning	Remarks
25	Machine Coordinate System Reference Position (MPOS)	ILC018	-2^{31} to $2^{31}-1$	1 = 1 pulse for pulse unit Will not be updated if the machine is locked.	
27	Serial Command Response Monitor	IWC01A		SGDH Serial Command Response Monitor 1. Reading data 01H: Normal 41H: Data error 81H: Address error 2. Writing data 02H: Normal 42H: Data error 82H: Address error C2H: Response timeout	
28	Serial Command Address Monitor	ILC01B		Address Monitor during SGDH Serial Command Execution	
29	POSMAX Monitor (PMAXMON)	ILC01C	1 to $2^{31}-1$	1 = 1 reference unit Copies motion fixed parameter "POSMAX."	
31	Number of POSMAX Turns (PMAXTURN)	ILC01E	-2^{31} to $2^{31}-1$	1 = 1 rotation Raises or lowers the count each time POSMAX is exceeded. (Initializes to 0 at startup.)	
33	Serial command data monitor	IWC020		Data Monitor during SGDH Serial Command Execution	
35	Alarms (ALARM)	ILC022	Bit 0: SVERROR	Servo Amp Error	
			Bit 1: OTF	Positive Overtravel	
			Bit 2: OTR	Negative Overtravel	
			Bit 3: SOTF	Positive Software Limit	
			Bit 4: SOTR	Negative Software Limit	
			Bit 5:		
			Bit 6: TIMEOVER	Positioning Time Over	
			Bit 7: DISTOVER	Overspeed	
			Bit 8:		
			Bit 9:		
			Bit 10: MODERR	Control Mode Error	
			Bit 11: ZSET_NRDY	Zero Point Not Set	
			Bit 12:		
			Bit 13:		
			Bit 14: WDT-ERR	Servodriver Synchronous Communications Error	
			Bit 15:		
			Bit 16:		
			Bit 17: ABSOVER	ABS Encoder Rotations Exceeded	
Bit 18:					
Bit 19:	Not used.				
Bit 20 to 31:	Not used.				

No.	Name	Register No.	Bit Name (Setting Range)	Meaning	Remarks
37	Servo Driver Alarm Code (SVALARM)	IWC024	-32768 to 32767		Error Code for Absolute Position Read Errors
38	Servodriver I/O Monitor (SVIOMON)	IWC025	Bit 0: SIO		General Input Signal
			Bit 1: DEC		Deceleration Dog Switch
			Bit 2: P-OT		Forward Limit Switch Input
			Bit 3: N-OT		Reverse Limit Switch Input
			Bit 4: EXT1		External Input Signal 1
			Bit 5: EXT2		External Input Signal 2
			Bit 6: EXT3		External Input Signal 3
			Bit7 to 15:		Not used
39	Speed Reference Output Monitor (RVMON)	ILC026	-2^{31} to $2^{31}-1$		Enabled when speed reference value selection (OBC001D) = 0 1 = 1 reference unit/H scan
41	Position Buffer Read Data (CNMON)	ILC02A	-2^{31} to $2^{31}-1$		When motion command control flag BUF_R (OBC021F) = 1, position buffer data is copied.
43	Not used.	ILC02C	-		-
45	Integral Output Monitor (YIMON)	ILC02C	-2^{31} to $2^{31}-1$		
47	Calculated Reference Coordinate System Position (POS)	ILC02E	-2^{31} to $2^{31}-1$		1 = 1 reference unit
49	Primary Lag Monitor (LAGMON)	ILC030	-2^{31} to $2^{31}-1$		(PI output value - primary lag output value)
51	Position Loop Output Monitor (PIMON)	ILC032	-2^{31} to $2^{31}-1$		Position loop output value (value prior to adding the calculated feed forward value)
53	Position Monitor 2 (APOS2)	ILC034	-2^{31} to $2^{31}-1$		Position monitor 2 unit selection. This will vary with (OBC02D3). 1. OBC02D3 = 0 (With reference unit selected) 1 = 1 reference unit 2. OBC02D3 = 1 (With pulse unit selected) 1 = 1 pulse
55	Not used.	IWC036	-		-
56	Not used.	IWC037	-		-
57	Lower-place Two Words of the Encoder Position at Shutdown	ILC038	-2^{31} to $2^{31}-1$		1 = 1 pulse (*For ABS system unlimited length position control)
59	Upper-place Two Words of the Encoder Position at Shutdown	ILC03A			1 = 1 pulse (*For ABS system unlimited length position control)
61	Lower-place Two Words of the Pulse Position at Shutdown	ILC03C	-2^{31} to $2^{31}-1$		1 = 1 pulse (*For ABS system unlimited length position control)

C

No.	Name	Register No.	Bit Name (Setting Range)	Meaning	Remarks
63	Upper-place Two Words of the Pulse Position at Shutdown	ILC03E	-2^{31} to $2^{31}-1$	1 = 1 pulse (*For ABS system unlimited length position control)	

D Lists of System Registers

This section shows tables of the system (S) registers that store the operation status, error information, etc., for the MP940.

D.1 System (S) Register Allocations	D-2
D.2 System Service Registers	D-2
D.3 Scan Execution Status and Calendar.....	D-5
D.4 System Program Software Number and Available Program Memory	D-5



D.1 System (S) Register Allocations

SW00000	System service registers
SW00030	System status
SW00050	System error status
SW00080	User operation error status
SW00090	System service execution status
SW00100	Interrupt input error status
SW00110	User operation error status, details
SW00200	System I/O error status
SW00424	Reserved for the system
SW00500	System analysis status
SW00530	Reserved for the system
SW00600	System operation error status
SW00620	Reserved for the System
SW00800	Reserved for optional modules
SW01023	

D.2 System Service Registers

■ Registers Common to All Drawings

Name	Register No.	Remarks
High-speed Scan (H Scan)	SB000001	ON for only 1 scan, after H scan starts
System Scan (S Scan)	SB000002	ON for only 1 scan, after S scan starts
Low-speed Scan (L Scan)	SB000003	ON for only 1 scan, after L scan starts
Always ON	SB000004	

■ Registers Specific to DWG.H

Set at start of H scan

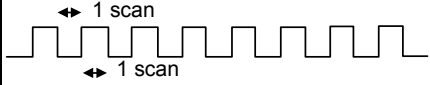
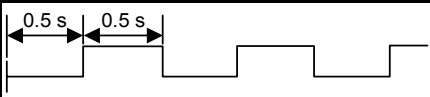
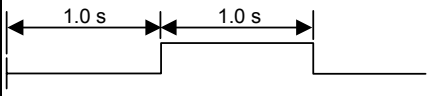
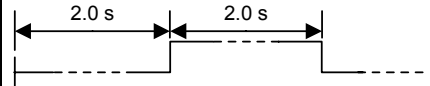
Name	Register No.	Remarks
1-scan Flicker Relay	SB000010	
0.5-s Flicker Relay	SB000011	
1.0-s Flicker Relay	SB000012	
2.0-s Flicker Relay	SB000013	



Name	Register No.	Remarks
0.5-s Sampling Relay	SB000014	
1.0-s Sampling Relay	SB000015	
2.0-s Sampling Relay	SB000016	
60.0-s Sampling Relay	SB000017	
Relay 1.0 s after Scan Processing Starts	SB000018	
Relay 2.0 s after Scan Processing Starts	SB000019	
Relay 5.0 s after Scan Processing Starts	SB00001A	

D

■ Registers Specific to DWG.S

Set at start of S scan

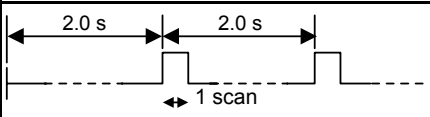
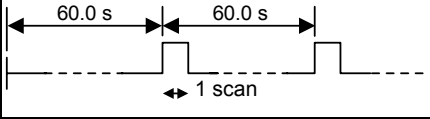
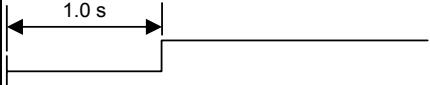
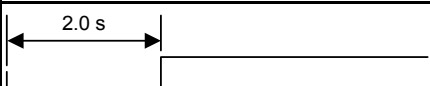
Name	Register No.	Remarks
1-scan Flicker Relay	SB000020	
0.5-s Flicker Relay	SB000021	
1.0-s Flicker Relay	SB000022	
2.0-s Flicker Relay	SB000023	
0.5-s Sampling Relay	SB000024	
1.0-s Sampling Relay	SB000025	

Name	Register No.	Remarks
2.0-s Sampling Relay	SB000026	
60.0-s Sampling Relay	SB000027	
Relay 1.0 s after Scan Processing Starts	SB000028	
Relay 2.0 s after Scan Processing Starts	SB000029	
Relay 5.0 s after Scan Processing Starts	SB00002A	

■ Registers Specific to DWGL

Set at start of L scan

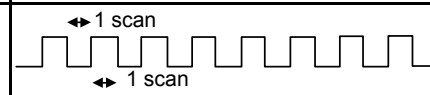
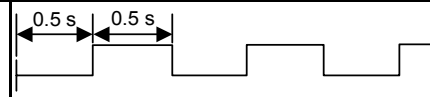
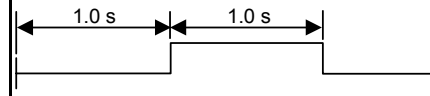
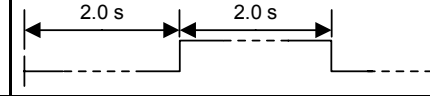
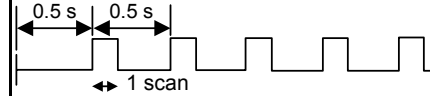
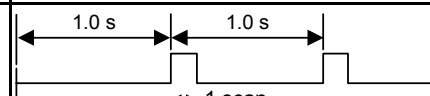
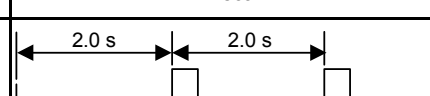
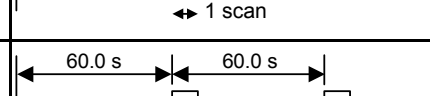
Name	Register No.	Remarks
1-scan Flicker Relay	SB000030	
0.5-s scan Flicker Relay	SB000031	
1.0-s scan Flicker Relay	SB000032	
2.0-s scan Flicker Relay	SB000033	
0.5-s Sampling Relay	SB000034	
1.0-s Sampling Relay	SB000035	
2.0-s Sampling Relay	SB000036	
60.0-s Sampling Relay	SB000037	

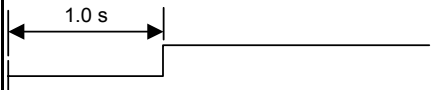
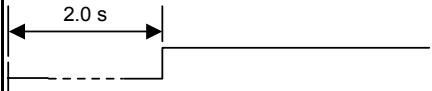
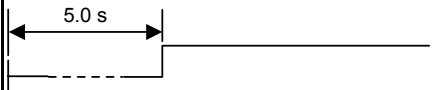
Name	Register No.	Remarks
Relay 1.0 s after Scan Processing Starts	SB000038	
Relay 2.0 s after Scan Processing Starts	SB000039	
Relay 5.0 s after Scan Processing Starts	SB00003A	

D.3 Scan Execution Status and Calendar

Name	Register No.	Remarks
High-speed Scan Set Value	SW00004	High-speed scan set value (0.01 ms)
High-speed Scan Current Value	SW00005	High-speed scan current value (0.01 ms)
H-speed Scan Maximum Value	SW00006	High-speed scan maximum value (0.01 ms)
System Scan Set Value	SW00007	System scan set value (0.01 ms)
System Scan Current Value	SW00008	System scan current value (0.01 ms)
System Scan Maximum Value	SW00009	System scan maximum value (0.01 ms)
Low-speed Scan Set Value	SW00010	Low-speed scan set value (0.01 ms)
Low-speed Scan Current Value	SW00011	Low-speed scan current value (0.01 ms)
Low-speed Scan Maximum Value	SW00012	Low-speed scan maximum value (0.01 ms)
Reserved by System	SW00013	Not used
Executing Scan Current Value	SW00014	Current value of scan being executed (0.01 ms)
Reserved by System	SW00015 to SW00019	Not used

D.4 System Program Software Number and Available Program Memory



Name	Register No.	Remarks
System Program Software Number	SW00020	Sxxxx (xxxx is stored as a BCD value)
System Number	SW00021 to SW00025	(Not used)
Remaining Program Memory Capacity	SW00026	Unit: Bytes
Total Module Memory Capacity	SW00028	Unit: Bytes

Revision History

The revision dates and numbers of the revised manuals are given on the bottom of the back cover.

MANUAL NO. SIEZ-C887-4.1

© Printed in Japan July 2002 00-9  Revision number
Date of original publication
Date of printing

Date of Printing	Rev. No.	Section	Revised Contents
September 2000	–		First edition
July 2002		Back cover	Revision: Address
December 2003		Back cover	Revision: Address
February 2006		3.2.1	Addition: Sentence in IMPORTANT Addition: Step 3 of Memory Initialization
		5.3.3	Revision: Cable models
		6.4.7	Addition: Section of other parameters
		Back cover	Revision: Address

Machine Controller MP940 USER'S MANUAL DESIGN AND MAINTENANCE

IRUMA BUSINESS CENTER (SOLUTION CENTER)

480, Kamifujisawa, Iruma, Saitama 358-8555, Japan
Phone 81-4-2962-5696 Fax 81-4-2962-6138

YASKAWA ELECTRIC AMERICA, INC.

2121 Norman Drive South, Waukegan, IL 60085, U.S.A.
Phone 1-847-887-7000 Fax 1-847-887-7370

YASKAWA ELÉTRICO DO BRASIL COMÉRCIO LTD.A.

Avenida Fagundes Filho, 620 Bairro Saude-Sao Paulo-SP, Brazil CEP: 04304-000
Phone 55-11-5071-2552 Fax 55-11-5581-8795

YASKAWA ELECTRIC EUROPE GmbH

Am Kronberger Hang 2, 65824 Schwalbach, Germany
Phone 49-6196-569-300 Fax 49-6196-569-312

YASKAWA ELECTRIC UK LTD.

1 Hunt Hill Orchardton Woods Cumbernauld, G68 9LF, United Kingdom
Phone 44-1236-735000 Fax 44-1236-458182

YASKAWA ELECTRIC KOREA CORPORATION

7F, Doore Bldg. 24, Yeoido-dong, Youngdungpo-Ku, Seoul 150-877, Korea
Phone 82-2-784-7844 Fax 82-2-784-8495

YASKAWA ELECTRIC (SINGAPORE) PTE. LTD.

151 Lorong Chuan, #04-01, New Tech Park 556741, Singapore
Phone 65-6282-3003 Fax 65-6289-3003

YASKAWA ELECTRIC (SHANGHAI) CO., LTD.

No.18 Xizang Zhong Road. Room 1702-1707, Harbour Ring Plaza Shanghai 200001, China
Phone 86-21-5385-2200 Fax 86-21-5385-3299

YASKAWA ELECTRIC (SHANGHAI) CO., LTD. BEIJING OFFICE

Room 1011A, Tower W3 Oriental Plaza, No.1 East Chang An Ave.,
Dong Cheng District, Beijing 100738, China
Phone 86-10-8518-4086 Fax 86-10-8518-4082

YASKAWA ELECTRIC TAIWAN CORPORATION

9F, 16, Nanking E. Rd., Sec. 3, Taipei, Taiwan
Phone 886-2-2502-5003 Fax 886-2-2505-1280



YASKAWA ELECTRIC CORPORATION

YASKAWA

In the event that the end user of this product is to be the military and said product is to be employed in any weapons systems or the manufacture thereof, the export will fall under the relevant regulations as stipulated in the Foreign Exchange and Foreign Trade Regulations. Therefore, be sure to follow all procedures and submit all relevant documentation according to any and all rules, regulations and laws that may apply.

Specifications are subject to change without notice for ongoing product modifications and improvements.

© 2000-2006 YASKAWA ELECTRIC CORPORATION. All rights reserved.

MANUAL NO. SIEZ-C887-4.1

Printed in Japan February 2006 00-9 -0
05-7