

YASKAWA AC Drive V1000 Option EtherNet/IP Installation Manual

Type: SI-EN3D/V

To properly use the product, read this manual thoroughly and retain for easy reference, inspection, and maintenance. Ensure the end user receives this manual.

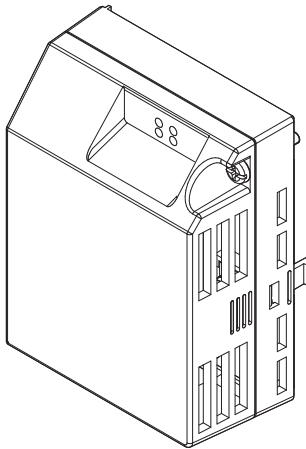

Copyright © 2014 YASKAWA AMERICA, INC. All rights reserved.

All rights reserved. No part of this publication may be reproduced, stored in a retrieval system, or transmitted, in any form or by any means, mechanical, electronic, photocopying, recording, or otherwise, without the prior written permission of Yaskawa. No patent liability is assumed with respect to the use of the information contained herein. Moreover, because Yaskawa is constantly striving to improve its high-quality products, the information contained in this manual is subject to change without notice. Every precaution has been taken in the preparation of this manual. Yaskawa assumes no responsibility for errors or omissions. Neither is any liability assumed for damages resulting from the use of the information contained in this publication.

Table of Contents



1	PREFACE AND SAFETY.....	4
2	PRODUCT OVERVIEW.....	9
3	RECEIVING.....	10
4	OPTION COMPONENTS.....	11
5	INSTALLATION PROCEDURE.....	16
6	RELATED DRIVE PARAMETERS.....	30
7	CONFIGURING MESSAGING.....	34
8	OUTPUT ASSEMBLIES (DRIVE CONSUMES)....	35
9	INPUT ASSEMBLIES (DRIVE PRODUCES).....	37
10	DEVICE LEVEL RING (DLR) GENERAL CLASS OBJECT.....	39
11	WEB INTERFACE.....	40
12	TROUBLESHOOTING.....	45
13	SPECIFICATIONS.....	50

1 Preface and Safety

Yaskawa manufactures products used as components in a wide variety of industrial systems and equipment. The selection and application of Yaskawa products remain the responsibility of the equipment manufacturer or end user. Yaskawa accepts no responsibility for the way its products are incorporated into the final system design. Under no circumstances should any Yaskawa product be incorporated into any product or design as the exclusive or sole safety control. Without exception, all controls should be designed to detect faults dynamically and fail safely under all circumstances. All systems or equipment designed to incorporate a product manufactured by Yaskawa must be supplied to the end user with appropriate warnings and instructions as to the safe use and operation of that part. Any warnings provided by Yaskawa must be promptly provided to the end user. Yaskawa offers an express warranty only as to the quality of its products in conforming to standards and specifications published in the Yaskawa manual. **NO OTHER WARRANTY, EXPRESS OR IMPLIED, IS OFFERED.** Yaskawa assumes no liability for any personal injury, property damage, losses, or claims arising from misapplication of its products.

◆ Applicable Documentation

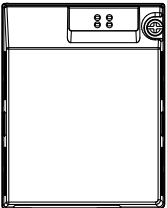
The following manuals are available for the SI-EN3D/V option:

	<p>Yaskawa AC Drive V1000 Option SI-EN3D/V Dual-Port EtherNet/IP Installation Manual (TOEYAI15)</p> <p>The Installation Manual contains information required to install the option and set up related drive parameters.</p> <p>Yaskawa AC Drive V1000 Option SI-EN3D/V Dual-Port EtherNet/IP Technical Manual (SIEPYAI15)</p> <p>The Technical Manual contains detailed information about the option. In the U.S., access http://www.yaskawa.com to obtain the Technical Manual. Customers in other areas should contact a Yaskawa representative.</p>
	<p>V1000 Series AC Drive Quick Start Guide</p> <p>This guide contains basic information required to install and wire the drive. It also gives an overview of fault diagnostics, maintenance, and parameter settings. The purpose of this guide is to prepare the drive for a trial run with an application and for basic operation. This manual is available for download on our documentation website, www.yaskawa.com.</p> <p>V1000 Series AC Drive Technical Manual</p> <p>This manual provides detailed information on parameter settings, drive functions, and MEMOBUS/Modbus specifications. Use this manual to expand drive functionality and to take advantage of higher performance features. This manual is available for download on our documentation website, www.yaskawa.com.</p>

◆ Terms

Note: Indicates supplemental information that is not related to safety messages.

Drive: Yaskawa V1000 Series AC Drive

Option: Yaskawa AC Drive V1000 SI-EN3D/V Dual-Port EtherNet/IP Option

◆ Registered Trademarks

- EtherNet/IP is a trademark of the ODVA.
 - All trademarks are the property of their respective owners.
-

◆ Supplemental Safety Information

Read and understand this manual before installing, operating, or servicing this option. The option must be installed according to this manual and local codes.

The following conventions are used to indicate safety messages in this manual. Failure to heed these messages could result in serious or possibly even fatal injury or damage to the products or to related equipment and systems.

DANGER

Indicates a hazardous situation, which, if not avoided, will result in death or serious injury.

WARNING

Indicates a hazardous situation, which, if not avoided, could result in death or serious injury.

WARNING! *may also be indicated by a bold key word embedded in the text followed by an italicized safety message.*

CAUTION

Indicates a hazardous situation, which, if not avoided, could result in minor or moderate injury.

CAUTION! *may also be indicated by a bold key word embedded in the text followed by an italicized safety message.*

1 Preface and Safety

NOTICE

Indicates a property damage message.

NOTICE: *may also be indicated by a bold key word embedded in the text followed by an italicized safety message.*

■ General Safety

General Precautions

- The diagrams in this manual may be indicated without covers or safety shields to show details. Replace the covers or shields before operating the drive and run the drive according to the instructions described in this manual.
- Any illustrations, photographs, or examples used in this manual are provided as examples only and may not apply to all products to which this manual is applicable.
- The products and specifications described in this manual or the content and presentation of the manual may be changed without notice to improve the product and/or the manual.
- When ordering a new copy of the manual due to damage or loss, contact your Yaskawa representative or the nearest Yaskawa sales office and provide the manual number shown on the front cover.
- If nameplate becomes worn or damaged, order a replacement from your Yaskawa representative or the nearest Yaskawa sales office.

DANGER

Heed the safety messages in this manual.

Failure to comply will result in death or serious injury.

The operating company is responsible for any injuries or equipment damage resulting from failure to heed the warnings in this manual.

Electrical Shock Hazard

Do not connect or disconnect wiring while the power is on.

Failure to comply will result in death or serious injury.

Failure to comply will result in death or serious injury. Before servicing, disconnect all power to the equipment. The internal capacitor remains charged even after the power supply is turned off. The charge indicator LED will extinguish when the DC bus voltage is below 50 Vdc. To prevent electric shock, wait for at least the time specified on the warning label once all indicators are OFF, and then measure the DC bus voltage level to confirm it has reached a safe level.

NOTICE

Observe proper electrostatic discharge procedures (ESD) when handling the drive and circuit boards.

Failure to comply may result in ESD damage to the drive circuitry.

Do not perform a withstand voltage test on any part of the drive.

Failure to comply could result in damage to the sensitive devices within the drive.

Do not operate damaged equipment.

Failure to comply could result in further damage to the equipment.

Do not connect or operate any equipment with visible damage or missing parts.

Do not expose the drive to halogen group disinfectants.

Failure to comply may cause damage to the electrical components in the drive.

Do not pack the drive in wooden materials that have been fumigated or sterilized.

Do not sterilize the entire package after the product is packed.

■ **Option Unit Warning Labels**

Warning information is displayed on the option unit as shown in the figure below. Follow all warnings and safety instructions when using the product.

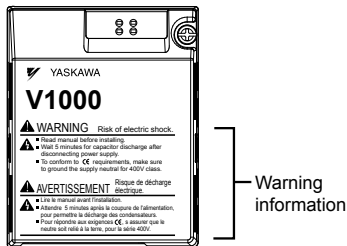

■ Warning Contents

WARNING Risk of electric shock.

- Read manual before installing.
- Wait 5 minutes for capacitor discharge after disconnecting power supply.
- To conform to **CE** requirements, make sure to ground the supply neutral for 400V class.

AVERTISSEMENT Risque de décharge électrique.

- Lire le manuel avant l'installation.
- Attendre 5 minutes après la coupure de l'alimentation, pour permettre la décharge des condensateurs.
- Pour répondre aux exigences **CE**, s'assurer que le neutre soit relié à la terre, pour la série 400V.

2 Product Overview

◆ About this Product

The option provides a communications connection between the drive and an ODVA EtherNet/IP network. The option connects the drive to an EtherNet/IP network and facilitates the exchange of data.

This manual explains the handling, installation and specifications of this product.

EtherNet/IP is a communications link to connect industrial devices (such as smart motor controllers, operator interfaces, and variable frequency drives) as well as control devices (such as programmable controllers and computers) to a network. EtherNet/IP is a simple, networking solution that reduces the cost and time to wire and install factory automation devices, while providing interchangeability of like components from multiple vendors.

EtherNet/IP is an open device network standard.

By installing the option to a drive, it is possible to do the following from an EtherNet/IP master device:

- Operate the drive
- Monitor drive status
- Change drive parameter settings.



◆ Applicable Models

The option can be used with the drive models in [Table 1](#).

Table 1 Applicable Models

Drive Series	Drive Model Number	Software Version <1>
V1000	CIMR-V□□□A□□□□	1012 and later

<1> See “PRG” on the drive nameplate for the software version number.

3 Receiving

Please perform the following tasks upon receipt of the option:

- Inspect the option for damage. Contact the shipper immediately if the option appears damaged upon receipt.
- Verify receipt of the correct model by checking the model number printed on the name plate of the option package.
- Contact your supplier if you have received the wrong model or the option does not function properly.

◆ Option Package Contents

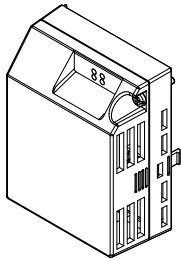
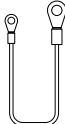
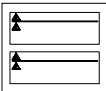
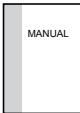
Description	Option Unit	Ground Wire	Warning Labels	Installation Manual
-				
Quantity	1	4	1	1

◆ Tools Required for Installation

A Phillips screwdriver (M3, M3.5 to M6 metric or #1, #2 U.S. standard) is required to install the option. Screw sizes vary by drive capacity. Select a screwdriver appropriate for the drive capacity.

Note: Tools required to prepare the option cables for wiring are not listed in this manual.

4 Option Components

◆ SI-EN3D/V Dual-Port EtherNet/IP Option Unit

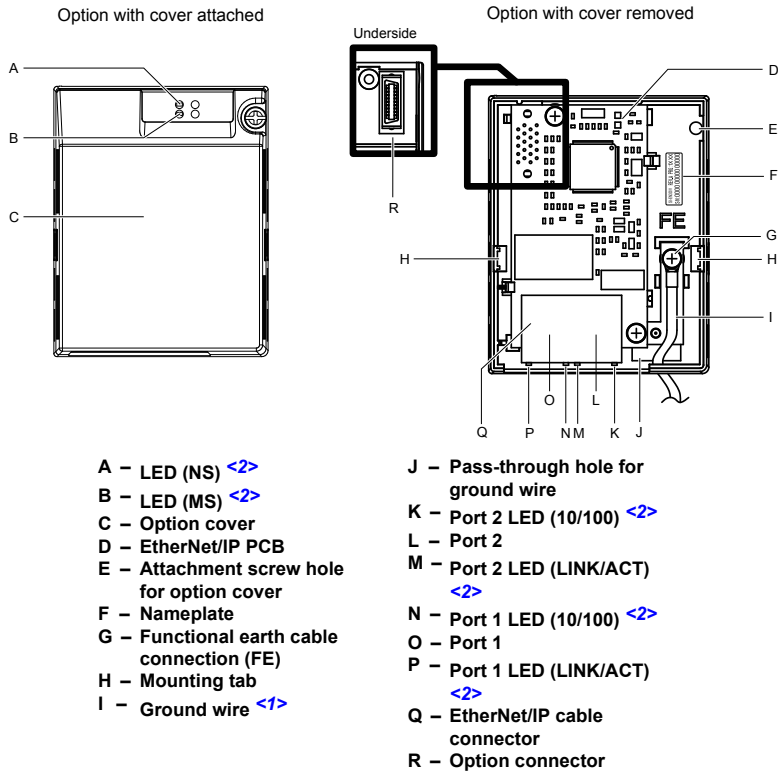

Figure 1 Option Unit Components

- <1> A selection of ground wires are packaged loose in the option shipping package. Connect the appropriate ground wire based on drive model during installation.
- <2> [Refer to Option LED Display on page 14](#) for details on the LEDs.

◆ Dimensions

The installed option adds 27 mm (1.06 in.) to the total depth of the drive.

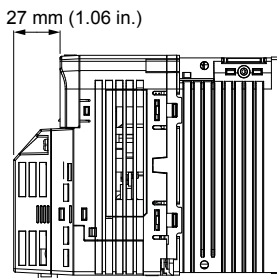

Figure 2 Dimensions

◆ Communication Connector CN1

Communication Connector CN1 is a modular RJ45 female connector and the connection point for a customer-supplied male Ethernet network communication cable.

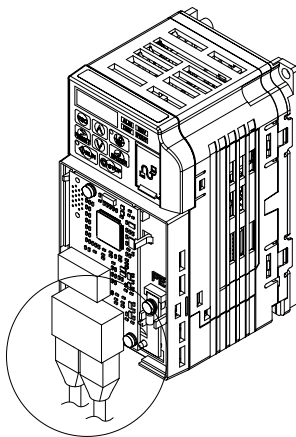
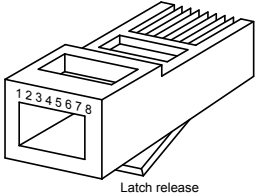

Figure 3 Communication Connector CN1 (RJ45)

Table 2 Male, 8-Way Ethernet Modular Connector (Customer-Supplied)

Male Ethernet 8-Way Modular Connector	Pin	Description
 <p style="text-align: center;">Latch release</p>	1 (Pair 2)	Transmit data (TXD) +
	2 (Pair 2)	Transmit data (TXD) -
	3 (Pair 3)	Receive data (RXD) +
	4 (Pair 1)	Not used <1>
	5 (Pair 1)	Not used <1>
	6 (Pair 3)	Receive data (RXD) -
	7 (Pair 4)	Not used <1>
	8 (Pair 4)	Not used <1>

<1> Not used for 10 Mbps and 100 Mbps networks.

◆ Option LED Display

The option has four LEDs.

Bi-color Status LEDs:

- Module status (MS) red/green
- Network status (NS) red/green

Ethernet LEDs:

- Network speed - 10/100 (MS) green
- Link status and network activity - LINK/ACT (NS) red/green

The operational states of the option LEDs after completion of the power-up diagnostic LED sequence are described in [Table 3](#). Wait at least 2 seconds for the power-up diagnostic process to complete before verifying LED states.

Table 3 Option LED States

Name	Display		Operating Status	Remarks
	Color	Status		
MS	–	OFF	Power supply OFF	Power is not being supplied to the drive.
	Green	ON	Normal operation	The option is operating normally and initialization is complete.
	Green	Flashing	Standby/Initializing	The option is in process of configuring or waiting for configuration information.
	Red	Flashing	Non-fatal error occurred	The option has detected a recoverable minor fault such as incomplete configuration.
	Red	ON	Fatal error occurred	The option has detected an unrecoverable major fault.
	Green/Red	Flashing	Option self-test	The option is in self-test mode.
NS	–	OFF	Power supply OFF	–
	Green	ON	Online communications established	The option is online and has established connections.
	Green	Flashing	Not connected	The option is online without an established connection.
	Red	Flashing	Minor fault	A minor recoverable fault has occurred.
	Red	ON	Major fault	The option detected a duplicate IP address.
	Green/Red	Flashing	Option self-test	The option is in self-test mode.

Name	Display		Operating Status	Remarks
	Color	Status		
10/100 < >	Green	OFF	10 Mbps is established	
	Green	ON	100 Mbps is established	
LINK/ACT < >	Green	OFF	LINK is not established	
	Green	ON	LINK is established	
	Green	Flashing	LINK is established and there is network activity.	

<|> Remove the cover to check the status of the LED. Be careful not to touch the main circuit terminals or the control board in the drive.

■ Power-Up Diagnostics

An LED test is performed each time the drive is powered up. The initial boot sequence may take several seconds. After the LEDs have completed the diagnostic LED sequence, the option is successfully initialized. The LEDs then assume operational conditions as shown in [Table 3](#).

Table 4 Power-Up Diagnostic LED Sequence

Sequence	Module Status (MS)	Network Status (NS)	Time (ms)
1	Green	OFF	250
2	Red	OFF	250
3	Green	OFF	–
4	Green	Green	250
5	Green	Red	250
6	Green	OFF	–

5 Installation Procedure

◆ Section Safety

DANGER

Electrical Shock Hazard

Do not connect or disconnect wiring while the power is on.

Failure to comply will result in death or serious injury.

Disconnect all power to the drive and wait at least the amount of time specified on the drive front cover safety label. After all indicators are off, measure the DC bus voltage to confirm safe level, and check for unsafe voltages before servicing. The internal capacitor remains charged after the power supply is turned off.

WARNING

Electrical Shock Hazard

Do not remove the option unit cover while the power is on.

Failure to comply could result in death or serious injury.

The diagrams in this section may include options and drives without covers or safety shields to show details. Be sure to reinstall covers or shields before operating any devices. The option should be used according to the instructions described in this manual.

Do not allow unqualified personnel to use equipment.

Failure to comply could result in death or serious injury.

Maintenance, inspection, and replacement of parts must be performed only by authorized personnel familiar with installation, adjustment, and maintenance of this product.

Do not use damaged wires, stress the wiring, or damage the wire insulation.

Failure to comply could result in death or serious injury.

Do not use damaged wires, place excessive stress on wiring, or damage the wire insulation.

Failure to comply could result in death or serious injury.

WARNING

Fire Hazard

Tighten all terminal screws to the specified tightening torque.

Loose electrical connections could result in death or serious injury by fire due to overheating of electrical connections.

NOTICE

Observe proper electrostatic discharge procedures (ESD) when handling the drive and circuit boards.

Failure to comply may result in ESD damage to the drive circuitry.

Never shut the power off while the drive is outputting voltage.

Failure to comply may cause the application to operate incorrectly or damage the drive.

Do not operate damaged equipment.

Failure to comply may cause further damage to the equipment.

Do not connect or operate any equipment with visible damage or missing parts.

Do not use unshielded cable for control wiring.

Failure to comply may cause electrical interference resulting in poor system performance.

Use shielded twisted-pair wires and ground the shield to the ground terminal of the drive.

Properly connect all pins and connectors.

Failure to comply may prevent proper operation and possibly damage equipment.

Check wiring to ensure that all connections are correct after installing the option and connecting any other devices.

Failure to comply could result in damage to the option.

◆ Prior to Installing the Option

Prior to installing the option, wire the drive, make necessary connections to the drive terminals, and verify that the drive functions normally without the option installed. Refer to the drive Quick Start Guide for information on wiring and connecting the drive.

◆ Installing the Option

DANGER! DANGER! Electrical Shock Hazard. Do not connect or disconnect wiring while the power is on. Failure to comply could result in death or serious injury. Before installing the option, disconnect all power to the drive and wait at least the amount of time specified on the drive front cover safety label. After all indicators are off, measure the DC bus voltage to confirm safe level, and check for unsafe voltages before servicing. The internal capacitor remains charged after the power supply is turned off.

1. Shut off power to the drive, wait at least five minutes after confirming the DC bus voltage is safe, then loosen the screw that fastens the front cover in place and remove the front cover. This drive front cover will be replaced by the option cover. Cover removal varies depending on drive size.

NOTICE: Damage to Equipment. Observe proper electrostatic discharge procedures (ESD) when handling the option, drive, and circuit boards. Failure to comply may result in ESD damage to circuitry.

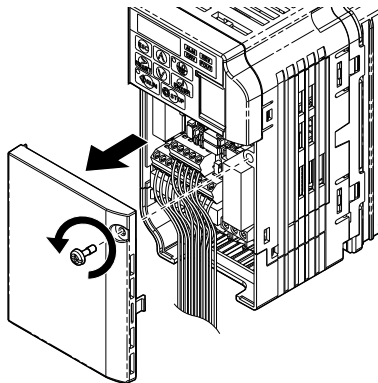

Figure 4 Remove the Front Cover

2. The remaining installation steps differ based on drive model. Find the drive model number on the drive nameplate and refer to the step indicated in [Table 5](#) based on your model number

Table 5 Installation Steps Based on Drive Model

Enclosure Type	Drive Model	Proceed to Step	Page
IP20/Open-Chassis	CIMR-V□□A□□□□□B	3	19
IP20/NEMA Type 1 <1>	CIMR-V□□A□□□□□F	6	20

Installing the option on an IP20/NEMA Type 1 enclosure drive voids NEMA Type 1 protection while maintaining IP20 conformity.

3. For IP20/Open-Chassis models CIMR-V□□A□□□□□B, remove the bottom cover of the drive by applying pressure to the tabs on each side of the bottom cover. Pull the bottom cover away from the drive while pushing in on the tabs to release the cover from the drive. Refer to [Figure 5](#) for details.

Refer to [Figure 6](#) for drive models BA0006B to BA0018B, 2A0008B to 2A0069B, and 4A0001B to 4A0038B, which require removing the terminal cover prior to removing the bottom cover.

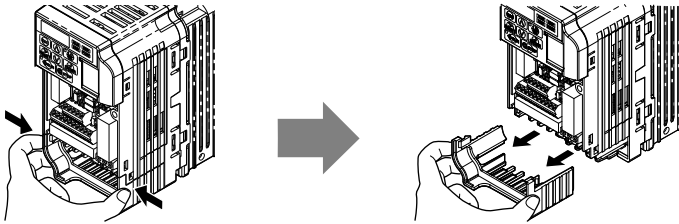

**Figure 5 Remove the Bottom Cover on an IP20/Open-Chassis Drive
(Models BA0001B to BA0003B and 2A0001B to 2A0006B)**

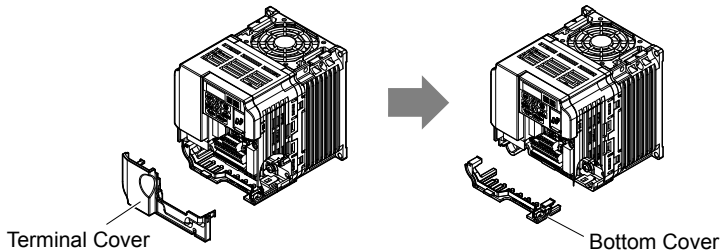

**Figure 6 Remove the Terminal Cover and Bottom Cover on an IP20/Open-Chassis Drive
(Models BA0006B to BA0018B; 2A0008B to 2A0069B; 4A0001B to 4A0038B)**

5 Installation Procedure

- On IP20/Open-Chassis models, connect the drive side of the ground wire to the drive ground terminal.

Note: The different ground wires packaged with the option connect the option to different drive models. Select the proper ground wire depending on drive size. Refer to [Table 6](#) for ground wire selection by drive model.

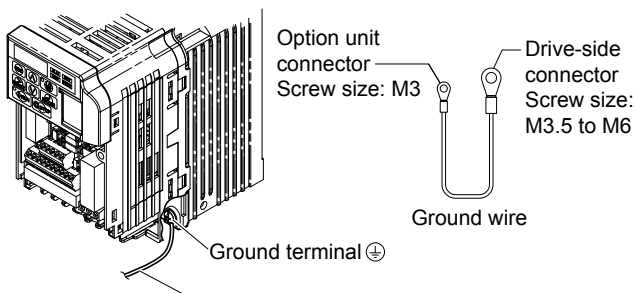

Figure 7 Connect the Ground Wire on an IP20/Open-Chassis Drive

Table 6 Ground Wire Selection

Ground Wire Length (mm/in)	Drive Model		
	Single-Phase 200 V Class	Three-Phase 200 V Class	Three-Phase 400 V Class
150/5.9	BA0001 BA0002 BA0003	2A0001 2A0002 2A0004 2A0006	—
200/7.9	BA0006 BA0010 BA0012 BA0018	2A0010 2A0012 2A0020	4A0001 4A0002 4A0004 4A0005 4A0007 4A0009 4A0011
250/9.8	—	2A0030 2A0040	4A0018 4A0023
400/15.7	—	2A0056 2A0069	4A0031 4A0038

- For IP20/Open-Chassis models, go to Step 9. on page 36.
- For IP20/NEMA Type 1 enclosure models CIMR-V□□A□□□□F, loosen the screw on the front of the NEMA Type 1 terminal cover and remove it from the drive. Refer to [Figure 8](#) for details.

Refer to [Figure 9](#) for drive models BA0006F to BA0018F, 2A0010F to 2A0069F, and 4A0001F to 4A0038F, which require removing the plastic terminal cover prior to removing the NEMA Type 1 terminal cover.

Note: Installing the option on an IP20/NEMA Type 1 enclosure drive voids NEMA Type 1 protection while maintaining IP20 conformity.

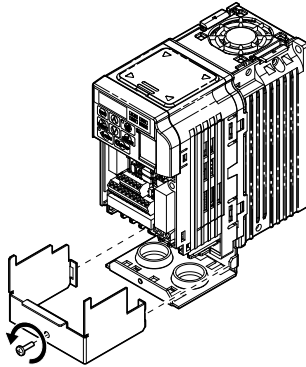

**Figure 8 Remove the NEMA Type 1 Terminal Cover
(Models BA0001F to BA0003F and 2A0001F to 2A0006F)**

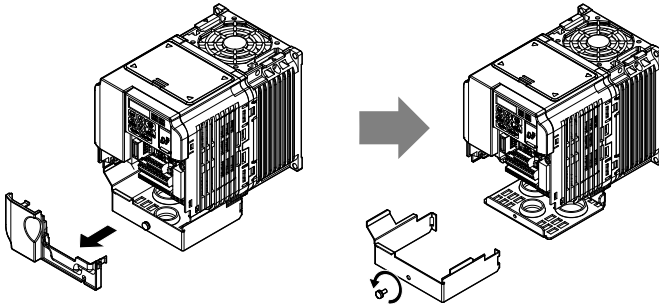

**Figure 9 Remove the Terminal Cover on an IP20/NEMA Type 1 Drive
(Models BA0006F to BA0018F; 2A0008F to 2A0069F; 4A0001F to 4A0038F)**

7. For models BA0001F to BA0003F and 2A0001F to 2A0006F, loosen the screws attaching the NEMA Type 1 conduit bracket to the drive to remove the NEMA Type 1 conduit bracket.

5 Installation Procedure

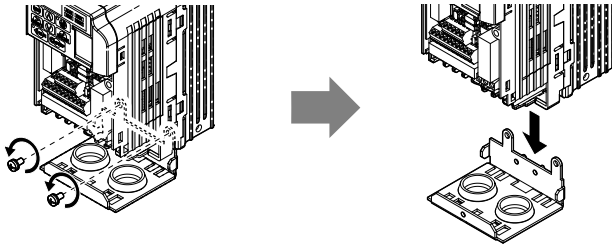

Figure 10 Remove the NEMA Type 1 Conduit Bracket (Models BA0001F to BA0003F and 2A0001F to 2A0006F)

- On models (BA0001F to BA0003F and 2A0001F to 2A0006F), the screw for the drive ground terminal also acts as one of the screws that attaches the NEMA Type 1 conduit bracket to the drive. Reattach the NEMA Type 1 conduit bracket according to Figure 27 and connect the drive-side of the ground wire to the drive ground terminal.

Note: The different ground wires packaged with the option connect the option to different drive models. Select the proper ground wire depending on drive size. Refer to [Table 6](#) on page 20 for ground wire selection by drive model.

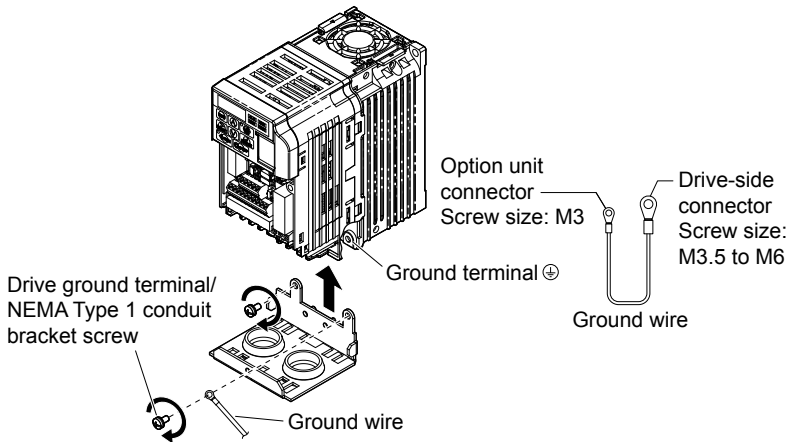

Figure 11 Reattach the NEMA Type 1 Conduit Bracket and Connect the Ground Wire (Models BA0001F to BA0003F and 2A0001F to 2A0006F)

9. Reattach the bottom cover. Keep the ground wire inside of the bottom cover when reattaching.

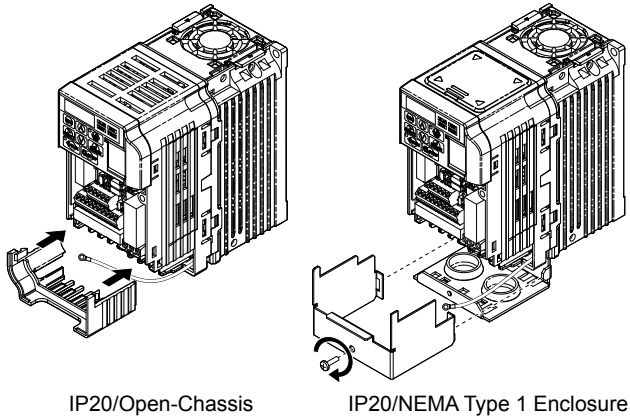

Figure 12 Reattach the Bottom Cover

10. On models BA0006 to BA0018, 2A0008 to 2A0069, and 4A0001 to 4A0038, reattach the terminal cover.

Refer to [Figure 13](#) and [Figure 14](#) for drive models BA0006 to BA0018, 2A0008 to 2A0020, and 4A0001 to 4A0011, which require routing the ground wire through the provided notch when reinstalling the terminal cover.

5 Installation Procedure

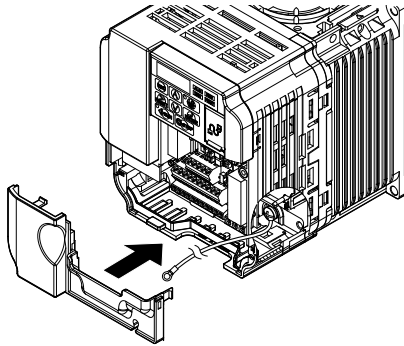

Figure 13 Reattach the Terminal Cover
(Models BA0006 to BA0018; 2A0008 to 2A0069; 4A0001 to 4A0038)

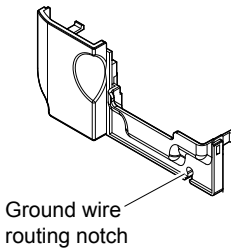

Figure 14 Terminal Cover Ground Wire Notch
(Models BA0006 to BA0018; 2A0008 to 2A0020; 4A0001 to 4A0011)

- 11.** Remove the option cover and pass the ground wire through the inside of the drive bottom cover and into the through-hole for the ground wire at the front of the option.

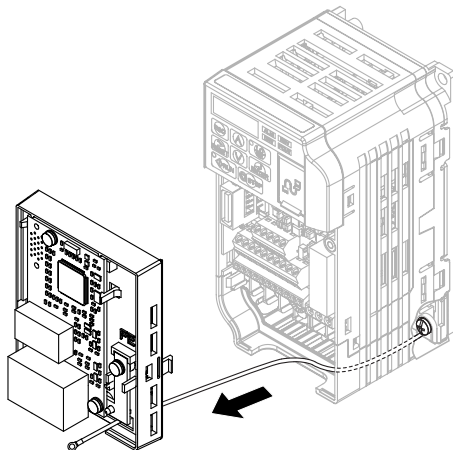

Figure 15 Ground Wire Routing

12. Attach the option to the drive. Properly seat the tabs on the left and right sides of the option to the drive case.

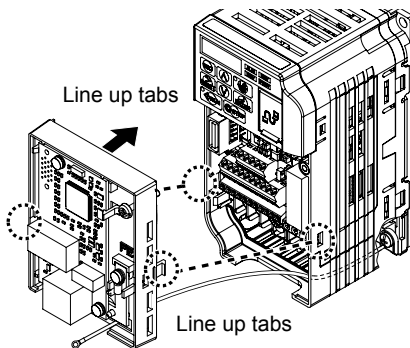

Figure 16 Connect the Option

13. Connect the ground wire at the option ground terminal. Tighten the screw to 0.5 to 0.6 N·m or (4.4 to 5.3 in lbs) using an M3 Phillips screwdriver.

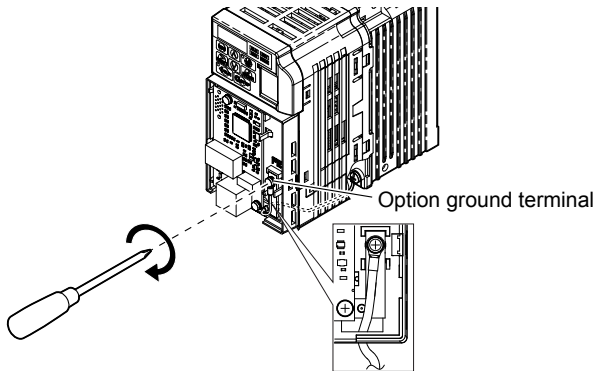

Figure 17 Connect the Ground Wire to the Option

- 14.** Connect the Ethernet communication cable to the option modular connector (CN1) port 1.

To connect the option to a network, firmly connect RJ45 8-pin shielded twisted pair Cat5e cable(s) into the modular connector ports (see [Figure 18](#)).

IGMP Snooping

Switches implementing IGMP Snooping are strongly recommended. When IGMP Snooping is used, devices will only receive the multicast packets in which they are interested.

Communication Cable Specifications

Only use cable recommended for EtherNet/Industrial Protocol (EtherNet/IP™). Using a cable not specifically recommended may cause the option or drive to malfunction. Refer to the ODVA website for more information on network cabling (<http://www.odva.org>).

The dual RJ45 network ports on the option board act as a switch to allow for flexibility in cabling topology. For example, a traditional star network topology may be employed by using a single port on the option board. Alternatively, a daisy-chained approach may be employed by using both RJ45 ports. The daisy-chained approach reduces the requirements of central switch ports. A ring topology is also possible.

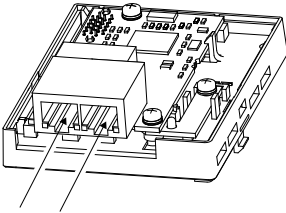

Figure 18 Communication Cable Ports

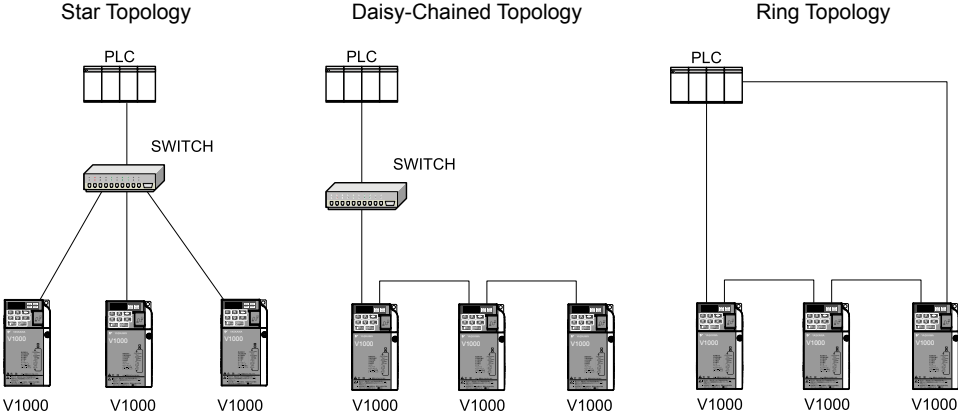

Figure 19 Topology Options

5 Installation Procedure

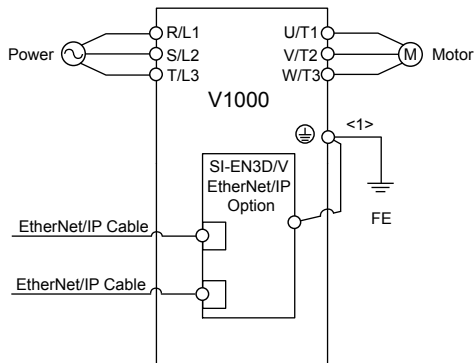

Figure 20 Option Connection Diagram

- 15.** Use the second communication cable port to daisy chain a series of drives where applicable.
- 16.** Attach the option cover by aligning the tabs with the mounting holes, seat the front cover into place, and tighten the screw on the front.

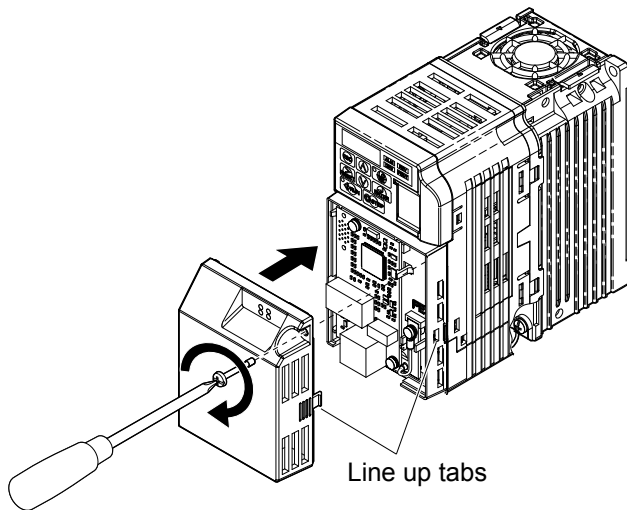

Figure 21 Attach the Option Cover

Note: Take proper precautions when wiring the option so that the front covers will easily fit back onto the drive. Make sure no cables are pinched between the front covers and the drive when replacing the covers.

17. Set drive parameters in [Table 7](#) for proper option performance.

◆ EDS Files

For easy network implementation of drives equipped with the option, an EDS file can be obtained from:

U.S.: <http://www.yaskawa.com>

Europe: <http://www.yaskawa.eu.com>

Japan: <http://www.e-mechatronics.com>

Other areas: Contact a Yaskawa representative.

Note: Download the option EDS file. The option will not function as a slave in the network without the appropriate EDS file.

6 Related Drive Parameters

The following parameters are used to set up the drive for operation with the option. Parameter setting instructions can be found in the drive manual.

Confirm proper setting of the parameters in [Table 7](#) before starting network communications. After changing parameter settings, cycle power to the drive for the new settings to take effect.

Table 7 Related Parameters

No. (Addr. Hex)	Name	Description	Values
b1-01 (0180) </>	Frequency Reference Selection 1	0: Digital operator 1: Analog input terminals 2: MEMOBUS/Modbus communications 3: Option PCB 4: Pulse input (terminal RP)	Default: 1 Range: 0 to 4
b1-02 (0181) </>	Run Command Selection 1	0: Digital operator 1: Digital input terminals 2: MEMOBUS/Modbus communications 3: Option PCB	Default: 1 Range: 0 to 3
F6-01 (03A2)	Communications Error Operation Selection	0: Ramp to stop. Decelerate to stop using the deceleration time in C1-02. 1: Coast to stop 2: Fast Stop. Decelerate to stop using the deceleration time in C1-09. 3: Alarm only </>	Default: 1 Range: 0 to 3
F6-02 (03A3)	External Fault from Comm. Option Detection Selection	1: Detection during run only	Default: 0 Range: 0, 1
F6-03 (03A4)	External Fault from Comm. Option Operation Selection	0: Ramp to stop. Decelerate to stop using the deceleration time in C1-02. 1: Coast to stop 2: Fast Stop. Decelerate to stop using the deceleration time in C1-09. 3: Alarm only </>	Default: 1 Range: 0 to 3
F6-07 (03A8)	Multi-Step Speed Enable/Disable Selection when NefRef/ComRef is Selected	0: Multi-step reference disabled (same as F7) 1: Multi-step reference enabled (same as V7)	Default: 1 Range: 0, 1
F6-08 (036A) </>	Reset Communication Parameters	0: Communication-related parameters (F6-□□/F7-□□) are not reset when the drive is initialized using A1-03. 1: Reset all communication-related parameters (F6-□□/F7-□□) when the drive is initialized using A1-03.	Default: 0 Range: 0, 1
F6-14 (03BB)	bUS Error Auto Reset	0: Disabled 1: Enabled	Default: 0 Range: 0, 1

6 Related Drive Parameters

No. (Addr. Hex)	Name	Description	Values
F7-01 (03E5) <4>	IP Address 1	Sets the most significant octet of network static IP address.	Default: 192 Range: 0 to 255
F7-02 (03E6) <4>	IP Address 2	Sets the second most significant octet of network static IP address.	Default: 168 Range: 0 to 255
F7-03 (03E7) <4>	IP Address 3	Sets the third most significant octet of network static IP address.	Default: 1 Range: 0 to 255
F7-04 (03E8) <4>	IP Address 4	Sets the fourth most significant octet of network static IP address.	Default: 20 Range: 0 to 255
F7-05 (03E9)	Subnet Mask 1	Sets the most significant octet of network static Subnet Mask.	Default: 255 Range: 0 to 255
F7-06 (03EA)	Subnet Mask 2	Sets the second most significant octet of network static Subnet Mask.	Default: 255 Range: 0 to 255
F7-07 (03EB)	Subnet Mask 3	Sets the third most significant octet of network static Subnet Mask.	Default: 255 Range: 0 to 255
F7-08 (03EC)	Subnet Mask 4	Sets the fourth most significant octet of network static Subnet Mask.	Default: 0 Range: 0 to 255
F7-09 (03ED)	Gateway Address 1	Sets the most significant octet of network Gateway address.	Default: 192 Range: 0 to 255
F7-10 (03EE)	Gateway Address 2	Sets the second most significant octet of network Gateway address.	Default: 168 Range: 0 to 255
F7-11 (03EF)	Gateway Address 3	Sets the third most significant octet of network Gateway address.	Default: 1 Range: 0 to 255
F7-12 (03E0)	Gateway Address 4	Sets the fourth most significant octet of network Gateway address.	Default: 1 Range: 0 to 255
F7-13 (03F1)	Address Mode at Startup	Select the option address setting method 0: Static <5> 1: BOOTP 2: DHCP	Default: 2 Range: 0 to 2
F7-14 (03F2)	Duplex Mode Selection	Selects duplex mode setting. 0: Half duplex forced (both ports) <6> 1: Auto-negotiate duplex mode and communication speed (both ports) 2: Full duplex forced (both ports) <6> 3: Half (port 1)/Auto (port 2) 4: Half (Port 1)/Full (port 2) 5: Auto (port 1)/Half (port 2) 6: Auto (port 1)/Full (port 2) 7: Full (port 1)/Half (port 2) 8: Full (port 1)/Auto (port 2)	Default: <7> Range: 0 to 8 <8>

6 Related Drive Parameters

No. (Addr. Hex)	Name	Description	Values
F7-15 (03F3)	Communication Speed Selection	Sets the communication speed 0: 10 Mbps 10: 10 Mbps 100: 100 Mbps 101: 10 (Port 1)/100 Mbps (port 2) 102: 100 (Port 1)/10 Mbps (port 2)	Default: 10 <9> Range: 10; 100 to 102 <9>
F7-16 (03F4)	Communication Loss Timeout	Sets the timeout value for communication loss detection in tenths of a second. A value of 0 disables the connection timeout. Example: An entered value of 100 represents 10.0 seconds.	Default: 0.0 Min.: 0.0 Max.: 30.0
F7-17 (03F5)	EtherNet/IP Speed Scaling Factor	Sets the scaling factor for the speed monitor in EtherNet/IP Class ID 2AH Object.	Default: 0 Min.: -15 Max.: 15
F7-18 (03F6)	EtherNet/IP Current Scaling Factor	Sets the scaling factor for the output current monitor in EtherNet/IP Class ID 2AH Object.	Default: 0 Min.: -15 Max.: 15
F7-19 (03F7)	EtherNet/IP Torque Scaling Factor	Sets the scaling factor for the torque monitor in EtherNet/IP Class ID 2AH Object.	Default: 0 Min.: -15 Max.: 15
F7-20 (03F8)	EtherNet/IP Power Scaling Factor	Sets the scaling factor for the power monitor in EtherNet/IP Class ID 2AH Object.	Default: 0 Min.: -15 Max.: 15
F7-21 (03F9)	EtherNet/IP Voltage Scaling Factor	Sets the scaling factor for the voltage monitor in EtherNet/IP Class ID 2AH Object.	Default: 0 Min.: -15 Max.: 15
F7-22 (03FA)	EtherNet/IP Time Scaling	Sets the scaling factor for the time monitor in EtherNet/IP Class ID 2AH Object.	Default: 0 Min.: -15 Max.: 15
F7-23 to F7-32 (03FB to 0374)	Dynamic Output Assembly Parameters	Parameters used in Output Assembly 116. Each parameter contains a MEMOBUS/Modbus address. The value received for Output Assembly 116 will be written to this corresponding MEMOBUS/Modbus address. A MEMOBUS/Modbus address value of 0 means that the value received for Output Assembly 116 will not be written to any MEMOBUS/Modbus register.	Default: 0
F7-33 to F7-42 (0375 to 037E)	Dynamic Input Assembly Parameters	Parameters used in Input Assembly 166. Each parameter contains a MEMOBUS/Modbus address. The value sent for Input Assembly 166 will be read from this corresponding MEMOBUS/Modbus address. A MEMOBUS/Modbus address value of 0 means that the value sent for Input Assembly 166 is not defined by the user, therefore the option default register value will be returned.	Default: 0

- <1> To start and stop the drive with the EtherNet/IP master device using serial communications, set b1-02 to 3 or set the “Net Control” bit in the assemblies or Control Supervisor Object. To control the drive frequency reference of the drive via the master device, set b1-01 to 3 or set the Net Reference bit in the assemblies or AC/DC Object.
- <2> When set to 3, the drive will continue to operate when a fault is detected. Take safety measures, such as installing an emergency stop switch.
- <3> Parameter setting value is not reset to the default value when the drive is initialized.

6 Related Drive Parameters

- <4> Cycle power for setting changes to take effect.
- <5> When F7-13 is set to 0, parameters F7-01 to F7-12 must be set, and all IP Addresses (as defined with parameters F7-01 to F7-04) must be unique.
- <6> When F7-14 is set to 0 or 2, parameter F7-15 must be set.
- <7> Default setting differs depending on drive software version. PRG: 1012 to 1015: 0
PRG: 1016 and later: 1
- <8> Setting range differs depending on drive software version. PRG: 1012 to 1023, Range: 0 to 2
PRG: 1024 and later, Range: 0 to 8
- <9> Setting values differ depending on drive software version. PRG: 1012 to 1015, Default: 0; Range: 0, 10, 100
PRG: 1016 to 1023, Default: 10; Range: 10, 100
PRG: 1024 and later, Default: 10; Range: 10; 100 to 102

Table 8 Option Monitors

No.	Name	Description	Value Range
U6-80 to U6-83	Online IP Address	IP Address currently available; U6-80 is the most significant octet	0 to 255
U6-84 to U6-87	Online Subnet	Subnet currently available; U6-84 is the most significant octet	0 to 255
U6-88 to U6-91	Online Gateway	Gateway currently available; U6-88 is the most significant octet	0 to 255
U6-92	Online Speed	Link Speed	10: 10 Mbps 100: 100 Mbps
U6-93	Online Duplex	Duplex Setting	0: Half, 1: Full
U6-94	Port 2 Duplex	Port 2 Duplex Setting	0: Half, 1: Full
U6-95	Port 2 Speed	Port 2 Link Speed	10: 10 Mbps 100: 100 Mbps
U6-98	First Fault	First Option Fault	–
U6-99	Current Fault	Current Option Fault	–

7 Configuring Messaging

This section provides information on methods used to control the drive with the option installed.

◆ Drive Polled Configuration

The assemblies in [Table 9](#) are available for polled I/O:

Table 9 Supported Polled I/O Assemblies

Assembly Number (Hex)	Description	Type	Bytes	Page
20 (14)	Basic Speed Control Output	Output	4	35
21 (15)	Extended Speed Control Output	Output	4	36
22 (16)	Speed and Torque Control Output	Output	6	–
23 (17)	Extended Speed and Torque Control Output	Output	6	–
70 (46)	Basic Speed Control Input	Input	4	37
71 (47)	Extended Speed Control Input	Input	4	38
72 (48)	Speed and Torque Control Input	Input	6	–
73 (49)	Extended Speed and Torque Control Input	Input	6	–
100 (64)	(Vendor Specific Yaskawa Electric (YE) Assy)-MEMOBUS/Modbus Message Output	Output	5	–
101 (65)	(Vendor Specific Yaskawa Electric (YE) Assy)-Speed/Torque Control Output	Output	8	–
115 (73)	(Vendor Specific Yaskawa Electric (YE) Assy)-Extended Speed/Torque Control Output	Output	40	–
116 (74)	(Vendor Specific Yaskawa Electric (YE) Assy)-High Speed/Torque Control Output	Output	44	–
150 (96)	(Vendor Specific Yaskawa Electric (YE) Assy)-MEMOBUS/Modbus Message Input	Input	5	–
151 (97)	(Vendor Specific Yaskawa Electric (YE) Assy)-Speed/Torque Status Input	Input	8	–
155 (9B)	(Vendor Specific Yaskawa Electric (YE) Assy)- Extended Speed/ Torque Status Input	Input	40	–
166 (A6)	(Vendor Specific Yaskawa Electric (YE) Assy)-High Speed/Torque Status Input	Input	44	–

8 Output Assemblies (Drive Consumes)

Note: The convention in this manual is from the PLC perspective. As such, an assembly is called an “Output Assembly” when outputted from the PLC and received by this node. This section details “Output Assemblies” that are “Consumed” by this drive.

◆ Basic Speed Control Output - 20 (0x14)

Output Instance	Word	Byte	Bit 7	Bit 6	Bit 5	Bit 4	Bit 3	Bit 2	Bit 1	Bit 0	
20	0	0	–	–	–	–	–	Fault Reset	–	Run Fwd	
		1	–								
	1	2	Speed Reference (Low Byte)								
		3	Speed Reference (High Byte)								

Name	Description
Run Fwd	Forward Run Command 0: Stop 1: Forward Run
Fault Reset	Fault Reset (0 to 1 transition: Fault Reset)
Speed Reference	Speed Command Sets drive speed reference. Speed reference data: Frequency reference/2 ^{SS} (SS: Speed scale) Setting range: 0 to 0xFFFF Example: setting a reference of 4096 with a speed scale of 2: Speed reference data = 4096/2 ² = 1024 = 0x0400 Hex or 10.24 Hz Unit depends on o1-03.

8 Output Assemblies (Drive Consumes)

◆ Extended Speed Control Output - 21 (0x15)

Output Instance	Word	Byte	Bit 7	Bit 6	Bit 5	Bit 4	Bit 3	Bit 2	Bit 1	Bit 0	
21	0	0	–	NetRef	NetCtrl	–	–	Fault Reset	Run Rev	Run Fwd	
		1	–								
	1	2	Speed Reference (Low Byte)								
		3	Speed Reference (High Byte)								

Name	Description
Run Fwd	Forward Run Command 0: Stop 1: Forward Run
Run Rev	Reverse Run Command 0: Stop 1: Reverse Run
Fault Reset	Fault Reset (0 to 1 transition: Fault Reset)
NetCtrl	Run command from Network 0: Depends on b1-02 1: Enables the run command from network
NetRef	Speed reference from Network 0: Depends on b1-01 1: Enables the speed reference from network
Speed Reference	Speed Command Sets drive speed reference. Speed reference data: Frequency reference/ 2^{SS} (SS: Speed scale) Setting range: 0 to 0xFFFF Example: setting a reference of 4096 with a speed scale of 2: Speed reference data = $4096/2^2 = 1024 = 0x0400$ Hex Unit depends on o1-03.

9 Input Assemblies (Drive Produces)

Note: The convention in this manual is from the PLC perspective. An “Input Assembly” is outputted from this node and read by the PLC. This section details “Input Assemblies” that are “Produced” by this drive.

◆ Basic Speed Control Input - 70 (0x46)

Input Instance	Word	Byte	Bit 7	Bit 6	Bit 5	Bit 4	Bit 3	Bit 2	Bit 1	Bit 0	
70	0	0	–	–	–	–	–	Running 1 (FWD)	–	Faulted	
		1	–								
	1	2	Speed Actual (Low Byte)								
		3	Speed Actual (High Byte)								

Name	Description
Faulted	Faulted 0: No Faults Occurred 1: Fault Occurred
Running 1 (FWD)	Forward Running 0: Stop or Reverse Running 1: Forward Running
Speed Actual	Actual Drive Speed Monitors drive output frequency. Speed actual data: Output frequency x 2 ^{SS} (SS: Speed scale) Setting range: 0 to 0xFFFF For example, when output frequency of 1024 with a speed scale of 2: Speed actual data = 1024 x 2 ² = 4096 = 0x1000 Unit depends on o1-03.

9 Input Assemblies (Drive Produces)

◆ Extended Speed Control Input - 71 (0x47)

Input Instance	Word	Byte	Bit 7	Bit 6	Bit 5	Bit 4	Bit 3	Bit 2	Bit 1	Bit 0	
71	0	0	At Speed	Ref from Net	Ctrl from Net	Ready	Running 2 (REV)	Running 1 (FWD)	Warning	Faulted	
		1	Drive State								
	1	2	Speed Actual (Low Byte)								
		3	Speed Actual (High Byte)								

Name	Description
Faulted	Faulted 0: No Faults Occurred 1: Fault Occurred
Warning	Warning 0: No Warning Occurred 1: Warning Occurred
Running 1 (FWD)	Forward Running 0: Stop or Reverse Running 1: Forward Running
Running 2 (REV)	Reverse Running 0: Stop or Forward Running 1: Reverse Running
Ready	Drive Ready 0: Not Ready 1: Ready
Ctrl from Net	Status of Run command from Network 0: Run command is not from network 1: Run command is from network
Ref from Net	Status of Speed reference from Network 0: Speed reference is not from network 1: Speed reference is from network
At Speed	Speed Agree 0: No Speed Agree 1: Speed actual at speed reference
Drive State	Contains the value from the Control Supervisor (Class 0x29) Instance 1 Attribute 6.
Speed Actual	Actual Drive Speed Monitors drive output frequency. Speed actual data: Output frequency x 2 ^{SS} (SS: Speed scale) Setting range: 0 to 0xFFFF For example, when output frequency of 1024 with a speed scale of 2: Speed actual data = 1024 x 2 ² = 4096 = 0x1000 Unit depends on o1-03.

10 Device Level Ring (DLR) General Class Object

Device Level Ring (DLR) is a layer 2 protocol allowing for redundancy in EtherNet/IP based ring topology networks. DLR allows devices to be placed in a ring to reduce the need for switch hardware and cabling and allow for the detection and recovery of faults in the ring.

Refer to the option Technical Manual for more information on DLR.

Note: DLR is supported in option software versions VST800341 and later.

11 Web Interface

The option contains a series of web pages that allow for viewing of status and diagnostic information through a standard web browser.

The web page is accessed through a self-contained web server at port 80. Access the home page by typing the IP address of the option in a web browser. Example: "http://192.168.1.20"

The IP address of the option can be read using monitors U6-80 to U6-83 on the digital operator if it is unknown. *Refer to Option Monitors on page 33* for details.

The home page is an HTML-based page providing basic drive and option data and a link to an enhanced web page requiring a Java© enabled web browser.

Enhanced Web Page Notes:

- The Enhanced Web Pages use a series of Java© applets.
- PCs must have Java SE 6 Update 14 or later installed to view the enhanced web pages.
- The Java© applets require an internet connection to check the revocation status.
- When no internet connection is available, disable the revocation check by changing a Java setting in the PC: All Programs / Java / Configure Java / Advanced Tab. Set "Perform certificate checks on" to "Do not check".

Enhanced Web Page Tab	Page
Main Tab	42
Drive Status Tab	43
Network Tab	Refer to the option Technical Manual for details on this tab.
Email Alerts Tab	Refer to the option Technical Manual for details on this tab.
Parameter Access Tab </>	Refer to the option Technical Manual for details on this tab.
Configuration Tab </>	Refer to the option Technical Manual for details on this tab.
Custom Tab	44

</> Accessible after entering a valid password.

◆ HTML Home Page

The HTML home page provides basic drive and option data and a link to an enhanced web page.



Refresh the page to update values.

Device Information	Network Status
Protocol: EtherNet/IP	Msg Tx OK: 570
IP Address: 192.168.1.40	Msg Rx OK: 637
MAC ID: 00:20:B5:88:31:86	Msg Tx Dropped: 0
Serial Number: 123001236	Msg Rx Dropped: 0
Product Name: SI-EN3D	Msg Tx Errors: 1
Option Firmware Version: VST800340	Msg Rx Errors: 1
Drive Model: CIMR-VU2A0001	Current Connections: 1
Drive Firmware Version: 1022	Collisions: 0
Profnet Station Name: N/A	Tx Retry: 0

[Launch Enhanced Website](#)

To run the "Enhanced Website", Java ® must be enabled in your browser. If a connection to the Internet is not available, a change in the Java configuration is required: set "All Programs / Java / Configure Java / Advanced Tab / Perform certificate checks on" to "Do not check".

Copyright © 2014 Yaskawa America, Inc.

Figure 22 HTML Home Page

◆ Main Tab

The Main tab shows basic option information such as IP address, MAC address, and firmware version.

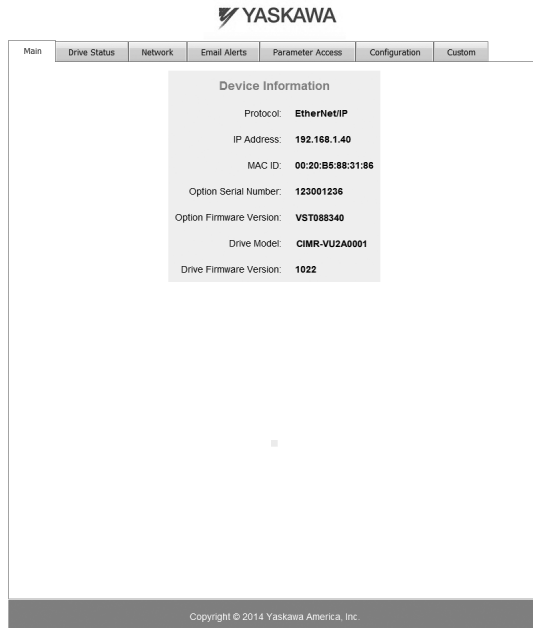

Figure 23 Main Tab View

◆ Drive Status Tab

The Drive Status tab shows basic I/O information and drive state information.

YASKAWA

Main	Drive Status	Network	Email Alerts	Parameter Access	Configuration	Custom																																										
<table border="1"> <thead> <tr> <th>Drive Status</th> <th>Drive Signals</th> <th>Fault Information</th> </tr> </thead> <tbody> <tr> <td>Status: Ready</td> <td>Frequency Ref: 0.0 Hz</td> <td>Active: None</td> </tr> <tr> <td>State: Stopped</td> <td>Output Frequency: 0.0 Hz</td> <td></td> </tr> <tr> <td>Direction: Forward</td> <td>Output Current: 0.0 A</td> <td></td> </tr> <tr> <td>Motor Speed: 0.0 Hz</td> <td>DC Bus Voltage: 344 V</td> <td></td> </tr> <tr> <td></td> <td>Torque Reference: +0%</td> <td></td> </tr> <tr> <th>Multi-function Inputs</th> <th>Multi-function Outputs</th> <th>Analog Input Signals</th> </tr> <tr> <td>Terminal S1: OFF</td> <td>Output MA - MC: OFF</td> <td>Input Terminal A1: 0%</td> </tr> <tr> <td>Terminal S2: OFF</td> <td>Output P1 - PC: OFF</td> <td>Input Terminal A2: 0%</td> </tr> <tr> <td>Terminal S3: OFF</td> <td>Output P2 - PC: OFF</td> <td></td> </tr> <tr> <td>Terminal S4: OFF</td> <td></td> <td></td> </tr> <tr> <td>Terminal S5: OFF</td> <td></td> <td></td> </tr> <tr> <td>Terminal S6: OFF</td> <td></td> <td></td> </tr> <tr> <td>Terminal S7: OFF</td> <td></td> <td></td> </tr> </tbody> </table>							Drive Status	Drive Signals	Fault Information	Status: Ready	Frequency Ref: 0.0 Hz	Active: None	State: Stopped	Output Frequency: 0.0 Hz		Direction: Forward	Output Current: 0.0 A		Motor Speed: 0.0 Hz	DC Bus Voltage: 344 V			Torque Reference: +0%		Multi-function Inputs	Multi-function Outputs	Analog Input Signals	Terminal S1: OFF	Output MA - MC: OFF	Input Terminal A1: 0%	Terminal S2: OFF	Output P1 - PC: OFF	Input Terminal A2: 0%	Terminal S3: OFF	Output P2 - PC: OFF		Terminal S4: OFF			Terminal S5: OFF			Terminal S6: OFF			Terminal S7: OFF		
Drive Status	Drive Signals	Fault Information																																														
Status: Ready	Frequency Ref: 0.0 Hz	Active: None																																														
State: Stopped	Output Frequency: 0.0 Hz																																															
Direction: Forward	Output Current: 0.0 A																																															
Motor Speed: 0.0 Hz	DC Bus Voltage: 344 V																																															
	Torque Reference: +0%																																															
Multi-function Inputs	Multi-function Outputs	Analog Input Signals																																														
Terminal S1: OFF	Output MA - MC: OFF	Input Terminal A1: 0%																																														
Terminal S2: OFF	Output P1 - PC: OFF	Input Terminal A2: 0%																																														
Terminal S3: OFF	Output P2 - PC: OFF																																															
Terminal S4: OFF																																																
Terminal S5: OFF																																																
Terminal S6: OFF																																																
Terminal S7: OFF																																																

Copyright © 2014 Yaskawa America, Inc.

Figure 24 Drive Status Tab View

◆ Custom Tab

The Custom tab displays a selection of quick setting parameters.

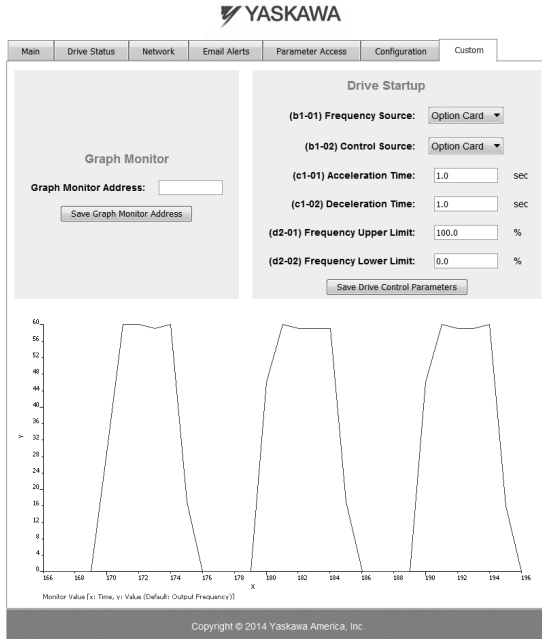

Figure 25 Custom Tab View

12 Troubleshooting

◆ Drive-Side Error Codes

Drive-side error codes appear on the drive digital operator. Causes of the errors and corrective actions are listed below. Refer to the drive manual for additional error codes that may appear on the drive digital operator.

■ Faults

Both bUS (Option Communication Error) and EF0 (Option Card External Fault) can appear as an alarm or as a fault. When a fault occurs, the digital operator ALM LED remains lit. When an alarm occurs, the ALM LED flashes.

If communication stops while the drive is running, use the following questions as a guide to help remedy the fault:

- Is the option properly installed?
- Are the communication lines properly connected to the option? Are the wires loose?
- Is the controller program working? Has the controller/PLC CPU stopped?
- Did a momentary power loss interrupt communications?

Digital Operator Display		Fault Name
<i>bUS</i>	bUS	Option Communication Error
		<ul style="list-style-type: none"> • The connection was lost after establishing initial communication. • Only detected when the Run command or frequency reference is assigned to the option (b1-01 = 3 or b1-02 = 3).
Cause		Possible Solution
Master controller (PLC) has stopped communicating		<ul style="list-style-type: none"> • Check that power is supplied to the PLC • Check that PLC is not in program mode
Communication cable is not connected properly		<ul style="list-style-type: none"> • Check for faulty wiring • Correct any wiring problems
A data error occurred due to noise		<ul style="list-style-type: none"> • Check the various options available to minimize the effects of noise • Counteract noise in the control circuit, main circuit, and ground wiring • If a magnetic contactor is identified as a source of noise, install a surge absorber to the contactor coil • Make sure the cable used meets requirements • Make sure the option ground wire is connected between option FE terminal and the drive ground terminal connected to earth ground
Option is damaged		If there are no problems with the wiring and the error continues to occur, replace the option.

12 Troubleshooting

Digital Operator Display		Fault Name
EF0	EF0	Option Card External Fault
		The alarm function for an external device has been triggered.
Cause		Possible Solutions
An external fault was received from the PLC and F6-03 is set to a value other than 3.		<ul style="list-style-type: none"> Remove the cause of the external fault. Remove the external fault input from the PLC.
Problem with the PLC program		Check the PLC program and correct problems.

Digital Operator Display		Fault Name
oFA00	oFA00	Option Card Connection Error at Option Port CN5-A
		The option card is incompatible with the drive.
Cause		Possible Solution

Digital Operator Display		Fault Name
oFA01	oFA01	Option Card Fault
		Option not properly connected
Cause		Possible Solution
The option card connection is faulty		<ul style="list-style-type: none"> Turn off the power and reconnect the option card. Check if the option card is properly plugged into the option port. Make sure the card is fixed properly.

Digital Operator Display		Fault Name
oFA03	oFA03	Option Card Fault (port A)
		Option card self-diagnostic error
oFA04	oFA04	Option Card Fault (port A)
		An error occurred attempting to write to the option card memory.
oFA30 to oFA43	oFA30 to oFA43	Option Card Fault (port A)
		Communication ID error
Cause		Possible Solution
Option card or hardware is damaged.		Replace the option card. Contact Yaskawa for consultation.

■ Minor Faults and Alarms

Digital Operator Display		Minor Fault Name	
CALL	CALL	Serial Communication Transmission Error	
		Communication has not yet been established.	
Cause		Possible Solutions	Minor Fault (H2-□□ = 10)
Communications wiring is faulty, there is a short circuit, the wiring is incorrect, or the connections are poor.		<ul style="list-style-type: none"> Check for wiring errors. Correct the wiring. Check for disconnected cables and short circuits. Repair as needed. 	YES
Programming error on the master side.		Check communications at start-up and correct programming errors.	
Communications circuitry is damaged.		<ul style="list-style-type: none"> Perform a self-diagnostics check. If the problem continues, replace the control board or the entire drive. Contact Yaskawa for instructions on replacing the control board. 	

■ bUS Fault Tolerance

bUS Fault Auto-Restart

Parameter F6-14, bUS Fault Auto Reset Select, will appear when the option is installed.

Setting F6-14 = 0 (Disabled) or F6-01 = 3 or greater (Alarm only) will not affect standard default drive behavior.

Setting F6-14 = 1 (Enabled) AND F6-01 ≠ 3 (Fault) will cause the following operation: The bUS fault occurs after the F7-16 delay and the Run command is removed from the drive. Then the option throws a bUS fault to the drive. When the condition is removed, the option commands a fault reset and returns control of the drive to the EtherNet/IP network.

Note: The option will only read parameter F6-01 and F6-14 from the drive during power-up.

bUS Fault Delay

Parameter F7-16, Communications Loss Detection Time Delay, will appear when the option is installed.

The setting value of F7-16 is the length of time that the option will delay sending the bUS fault to the drive.

The status LEDs on the option are not affected by the delay time set in F7-16; the LEDs will indicate the bUS condition immediately.

Note: The option will only read parameter F7-16 from the drive during power-up.

■ Explicit Message Communications Errors

When there is a problem with a request message sent from the master in explicit communications, the drive will return one of the following error codes.

12 Troubleshooting

Table 10 Communications Errors and Solutions

Error Code (Hex)	Description	Cause	Possible Solution
08	Service not supported	The service code is incorrect.	Correct the service code.
09	Invalid attribute value	The attribute is incorrect.	Correct the attribute.
0C	Object state conflict	Attempted to change a drive constant that cannot be changed while the drive is running.	Stop the drive.
0E	Attribute not settable	Attempted to change a read-only attribute.	Correct the service code or attribute setting.
13	Not enough data	The data size is incorrect.	Correct the data size.
15	Too much data	The data size is incorrect.	Correct the data size.
16	Object does not exist	An unsupported object was specified.	Correct the class or instance setting.
1F	Vendor-specific error	Attempted to change a drive constant that cannot be changed while the drive is running. Attempted to change a drive constant to a value outside the setting range.	Stop the drive. Specify a value within the setting range.
20	Invalid parameter	Attempted to change to a data value outside the setting range.	Specify a data value within the setting range.

Note: Refer to the MEMOBUS/Modbus Data Table in the MEMOBUS/Modbus Communications chapter of the drive manual for a list of monitor data using the MEMOBUS/Modbus message area.

◆ Option Error Codes

■ Option Fault Monitors U6-98 and U6-99

The option can declare error/warning conditions via drive monitor parameters on the drive digital operator as shown in [Table 11](#).

Table 11 Option Fault Monitor Descriptions

Fault Condition	Fault Declared	Status Value (U6-98/U6-99)	Description
No Fault	n/a	0	No faults
Force Fault	EF0	3	Network sent a message to force this node to the fault state.
Network Link Down	BUS ERROR	1100	No network link to option.
Connection Timeout	BUS ERROR	1101	The node timer (Requested Packet Interval) timed out.
Duplicate IP Address	BUS ERROR	1102	This node and at least one other node have the same IP Address.

Fault Condition	Fault Declared	Status Value (U6-98/U6-99)	Description
Default MAC Address	None	1103	Factory default MAC Address programmed into the option. Return for reprogramming.

Two drive monitor parameters, U6-98 and U6-99 assist the user in network troubleshooting.

- U6-98 displays the first declared fault since the last power cycle. U6-98 is only cleared upon drive power-up.
- U6-99 displays the present option status. U6-99 is cleared upon a network-issued fault reset and upon power-up.

If another fault occurs while the original fault is still active, parameter U6-98 retains the original fault value and U6-99 stores the new fault status value.

13 Specifications

Table 12 Option Specifications

Item	Specification
Model	SI-EN3D/V
Supported Messages	Explicit: Explicit Class 3, Unconnected I/O: Class 1, Listen Only, Input Only
I/O Assembly Instance	Input: 8 types (4 to 44 Bytes) Output: 8 types (4 to 44 Bytes)
SI-EN3D Specification	Composite Test Revision: CT11 Passed
SI-EN3D Profile	AC Drive
Connector Type	RJ45 8-pin Straight Connector STP Cat5e cable
Physical Layer Type	Isolated Physical Layer TCP Protocol Transformer Isolated
IP Address Setting	Programmable from drive keypad or network
Communication Speed	Programmable from drive keypad or network: 10/100 Mbps, auto-negotiate
Number of Connections	I/O: 2 Explicit: 6
Duplex Mode	Half-forced, Auto-negotiate, Full-forced
Address Startup Mode	Static, BOOTP, DHCP
Ambient Temperature	-10 °C to +50 °C (14 °F to 122 °F)
Humidity	95% RH or lower with no condensation
Storage Temperature	-20 °C to +60 °C (-4 °F to +140 °F) allowed for short-term transport of the product
Area of Use	Indoor (free of corrosive gas, airborne particles, etc.)
Altitude	1000 m (3280 ft.) or lower

This Page Intentionally Blank

YASKAWA AC Drive V1000 Option EtherNet/IP Installation Manual

YASKAWA AMERICA, INC.

2121 Norman Drive South, Waukegan, IL 60085, U.S.A.

Phone: (800) YASKAWA (927-5292) or 1-847-887-7000 Fax: 1-847-887-7310

<http://www.yaskawa.com>

YASKAWA ELÉTRICO DO BRASIL LTDA.

Avenida Fagundes Filho, 620 Bairro Saude, São Paulo, SP04304-000, Brasil

Phone: 55-11-3585-1100 Fax: 55-11-5581-8795

<http://www.yaskawa.com.br>



YASKAWA AMERICA, INC.

In the event that the end user of this product is to be the military and said product is to be employed in any weapons systems or the manufacture thereof, the export will fall under the relevant regulations as stipulated in the Foreign Exchange and Foreign Trade Regulations. Therefore, be sure to follow all procedures and submit all relevant documentation according to any and all rules, regulations and laws that may apply.

Specifications are subject to change without notice for ongoing product modifications and improvements.

© 2014 YASKAWA AMERICA, INC. All rights reserved.



TOEPYAICOM15

MANUAL NO. TOEP YAICOM 15A

Published in U.S.A. May 2014 14-5